

Anya Module Specifications



DESCRIPTION

EAW Anya is a complete, self-contained, high-power sound reinforcement system that adapts all performance parameters electronically, allowing it to be used in virtually any application. Columns of Anya modules hang straight, without any vertical splay, and Resolution 2 software adapts total system performance to produce asymmetrical output that delivers coherent, full-frequency range response across the entire coverage area as defined by the user. It is extremely powerful and immensely scalable, making it suitable for anything from small venues to the largest stadiums.

Each Anya module includes 14x 1-in exit / 35mm voice coil HF compression drivers loaded on a proprietary HF horn that expands to fill nearly the entire face of the enclosure. 6x 5-in MF cone transducers, arranged in two columns of three, use Radial Phase Plugs™ and Concentric Summation Array™ technology to enter the horn and sum coherently with the HF wavefront. Dual 15-in LF cone transducers use Off-Center Aperture loading to increase the spacing of the apparent acoustical centers, extending effective horizontal pattern control well into the LF range.

The module's horizontal symmetry ensures coherent summation without anomalies through the crossover regions that result from physically-offset acoustic sources. This provides consistent, HF dispersion and broadband pattern control in the horizontal plane.

FEATURES

- Adaptive Performance™ manages coverage and directivity via Resolution™ 2 software
- Vastly simplified setup process as compared to typical large-format arrays; uses no vertical splay angles to achieve desired coverage
- On-board diagnostics and Adaptive Healing continuously monitor and correct performance in real time
- High-power, full-bandwidth; scalable to all performance types and venue sizes
- All amplification and processing on-board

APPLICATIONS

- Portable and touring sound reinforcement of any scale (from clubs to stadia and arenas)
- Installed sound reinforcement for performing arts venues, clubs, houses of worship or sports facilities of any size

Each Anya module includes a field-replaceable power and processing unit with 22 channels of digital signal processing and amplification to drive each of the module's 22 transducers.

Via Resolution 2 software, Adaptive Performance controls all performance parameters of the total array to develop an asymmetrical output profile shaped so that all listening locations as defined by the user receive nearly identical response. By carefully crafting the size and spacing of the transducers, EAW engineers enabled Anya to create radical coverage patterns (i.e., narrowly focused and directed almost straight down) while maintaining an appealing, musical sound quality.

Anya Module Specifications



3-WAY FULL-RANGE Array module

See NOTES TABULAR DATA for details

Configuration

Subsystem	Transducer	Loading
	LF 2x 15-in cone, 4 in voice coil	Vented, Phase Aligned™, Offset Aperture™ loading
	MF 6x 5-in cone, 38mm voice coil	Horn-loaded w/ Radial Phase Plug™ and CSA™ apertures
	HF 14x1-in exit, 35mm voice coil	Horn-loaded compression driver

Operating Mode

Amplifier Channels	Signal Processing
2x LF	DSP w/ EAW Focusing™ and Adaptive Performance™
6x MF	DSP w/ EAW Focusing™ and Adaptive Performance™
14x HF	DSP w/ EAW Focusing™ and Adaptive Performance™

Performance

Maximum SPL*	152 dB
Operating Range	35 Hz to 18 kHz
Nominal Beamwidth	Horz 70° (for single column; scalable up to 360° utilizing multiple columns)
	Vert Adaptive

* Calculated peak SPL with 4:1 (12dB) crest factor pink noise

Real-world SPL capabilities in audience planes will vary with enclosure quantity and system adaptation for a given audience area.

Anya Module Specifications

Electrical Performance

Input	
Type	Electronically Balanced
Max Input Level	25 dBu
Impedance	20 kOhm (balanced)
Wiring	XLR/F, Pin 1 chassis, pin 2 +, pin 3 – Separate loop-thru XLRM (for analog signal only)
Input Selection	Analog, AES (Ch 1/2), Dante

Amplifiers & Processing	LF	MF	HF
Type	Modified Class D	Modified Class D	Modified Class D
Maximum Output	2x 1,700W	6x 350W	14x 350W
Driver Protection	Integral DSP limiting	Integral DSP limiting	Integral DSP limiting

AC Mains (Nominal)	
Connector	Neutrik® powerCON™ TRUE1™
Input	100 V to 240 V
Frequency	50 Hz to 60 Hz
Power Consumption	Idle 250 W Peak Draw 1,600 W

Control/Communications

Connections	USB A & B, 2x Neutrik® etherCON™
Protocols	USB, Ethernet/Dante
Software	Resolution™ 2 (available at eaw.com)
Indicators	Test, Function, Input (Network, Analog, AES/EBU), Network Status
User Controls	Test, Function

Ordering Data

	Description	Part Number
	G24 System (24 modules) 115V	2042438
	G24 System (24 modules) 230V	2043118
Optional Accessories	Distro Rack (supports 12 modules) 115V	2041779
	Distro Rack (supports 12 modules) 230V	2042545
	Distro Flybar	2042596
	Distro Pallet	2042482
	Flybar	2041774
	Cable Power Loom (6 modules)	2045005
	Cable Power Extender (6 modules)	2045006
	Cable Network Loom Short (6 modules)	2045007
	Cable Network Loom Long (6 modules)	2045008
	Caster Pallet (4 modules)	2046221
	Cover (4 modules)	2041783
	Spare Transducer Service Pack	2041781
	Spare Amplifier Service Pack	2041778

Anya Module Specifications

Enclosure

Material Powder-coated cast aluminum; Exterior-grade Baltic birch plywood with wear-resistant textured RoadCoat™

Grille Powder-coated perforated steel

NOTE: This drawing has been reduced. Do not scale.

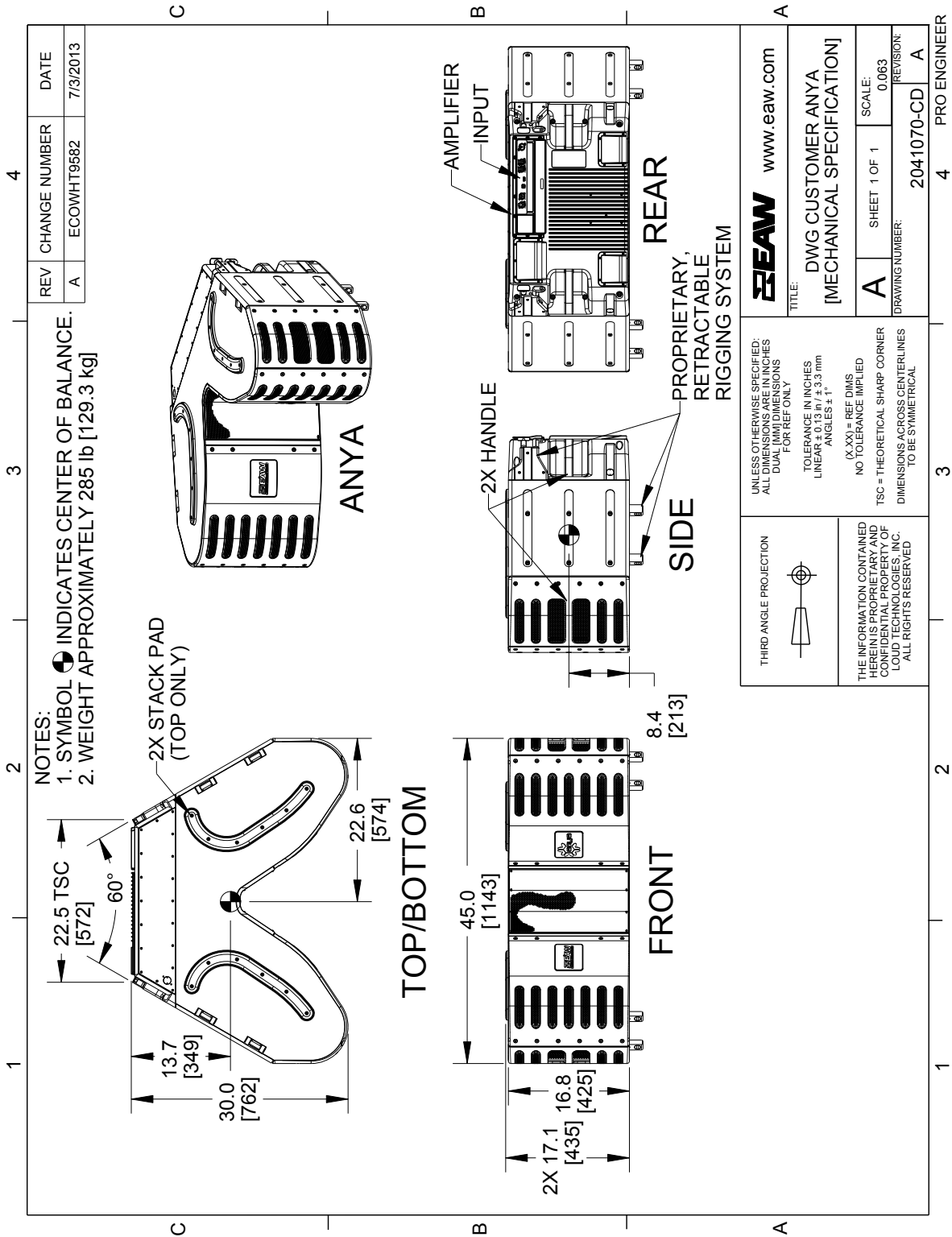

Anya Module Specifications

Performance Data, Unadapted

See NOTES GRAPHIC DATA for details

Frequency Response: Processed - Multi Amp

LF = green, MF = orange, HF = black, Complete = blue

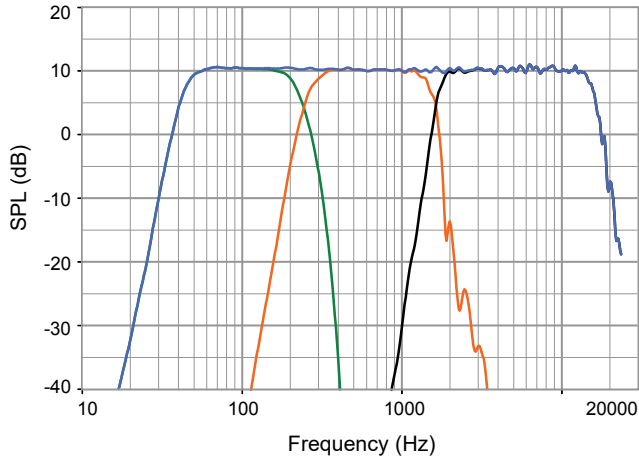

Beamwidth

Horizontal = orange, Vertical = black

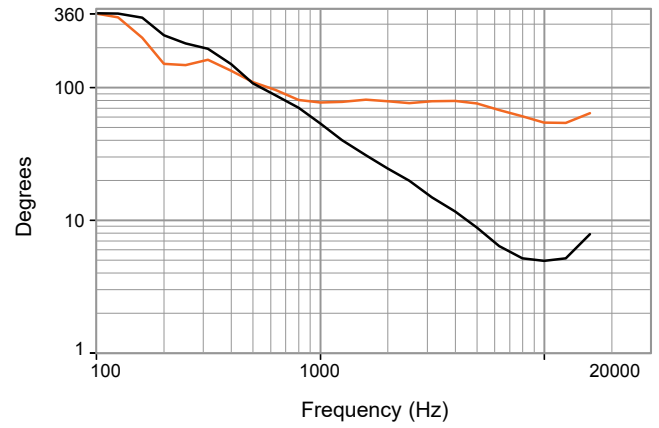

Phase Linearity

Complete = blue

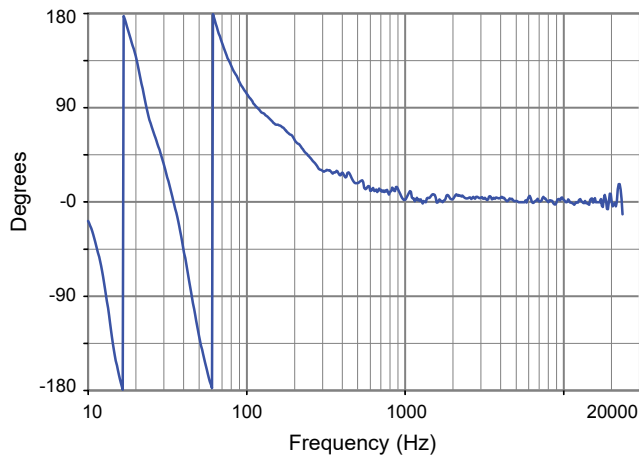

Anya Module Specifications

Horizontal Polar Data, Unadapted

See NOTES GRAPHIC DATA for details

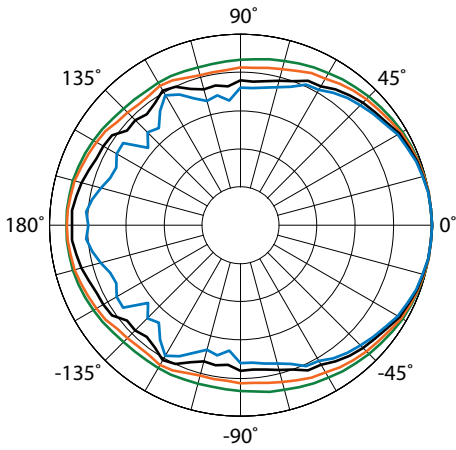

- 100Hz
- 125Hz
- 160Hz
- 200Hz

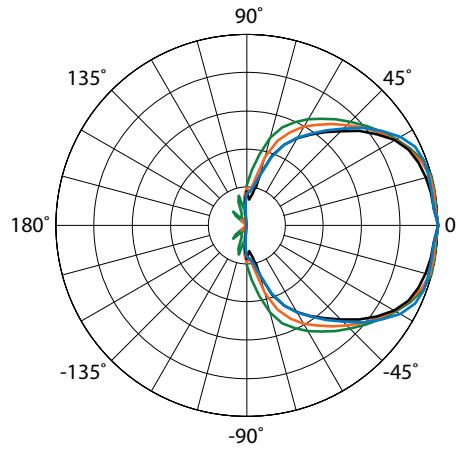

- 1600Hz
- 2000Hz
- 2500Hz
- 3150Hz

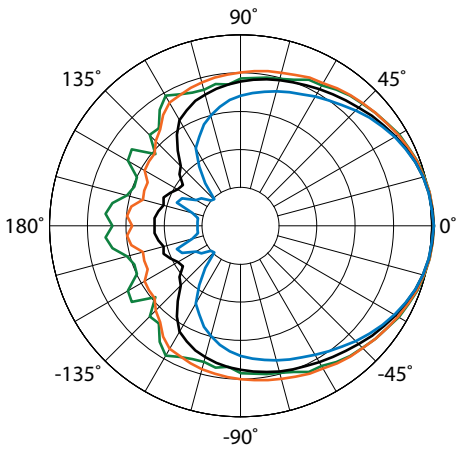

- 250Hz
- 315Hz
- 400Hz
- 500Hz

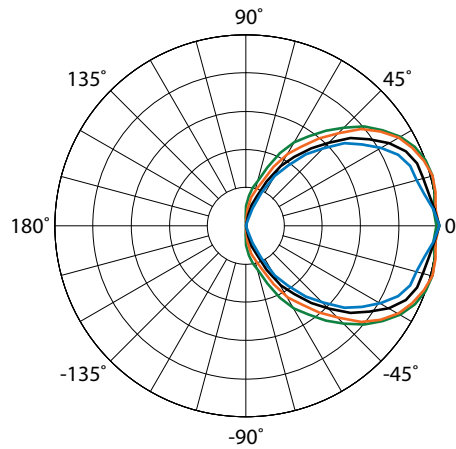

- 4000Hz
- 5000Hz
- 6300Hz
- 8000Hz

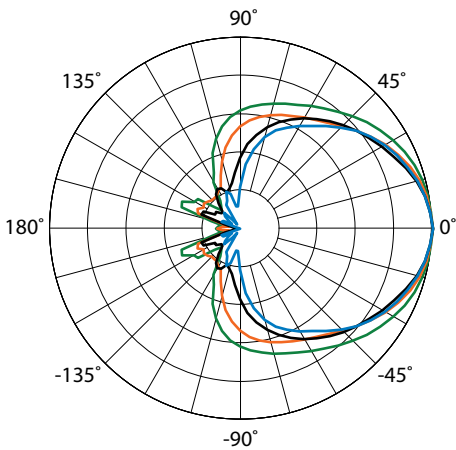

- 630Hz
- 800Hz
- 1000Hz
- 1250Hz

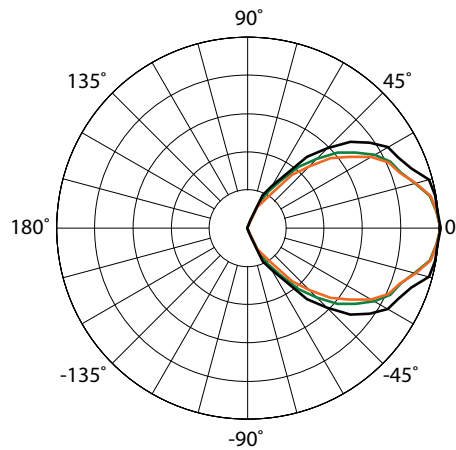

- 10000Hz
- 12500Hz
- 16000Hz

Anya Module Specifications

Vertical Polar Data, Unadapted

See NOTES GRAPHIC DATA for details

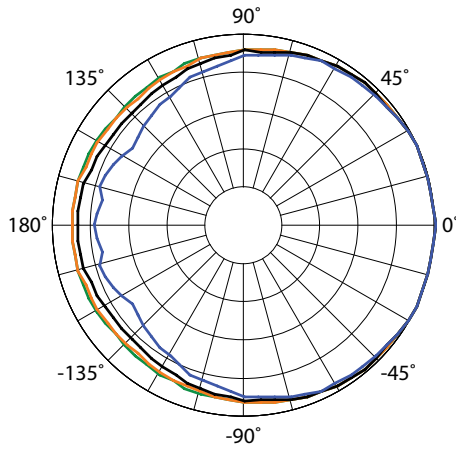

- 100Hz
- 125Hz
- 160Hz
- 200Hz

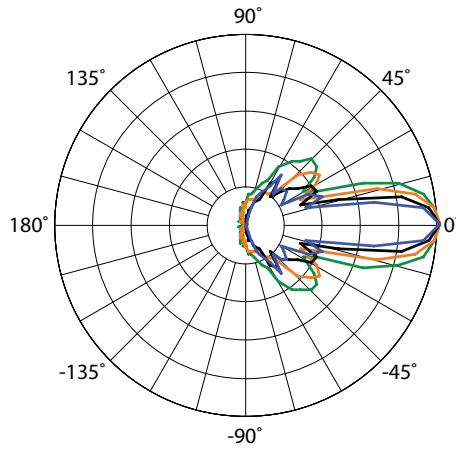

- 1600Hz
- 2000Hz
- 2500Hz
- 3150Hz

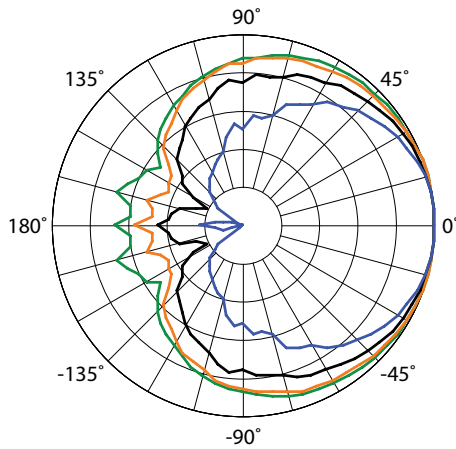

- 250Hz
- 315Hz
- 400Hz
- 500Hz

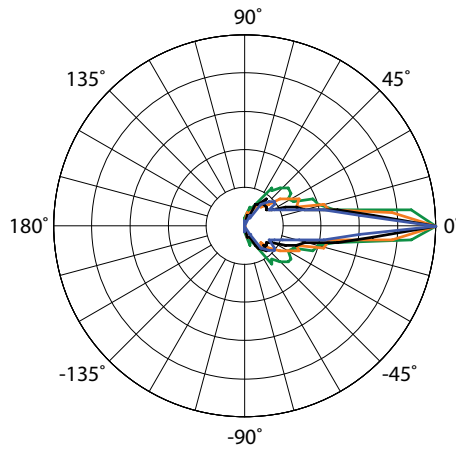

- 4000Hz
- 5000Hz
- 6300Hz
- 8000Hz

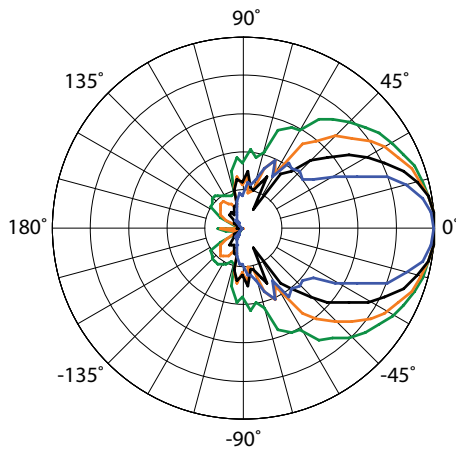

- 630Hz
- 800Hz
- 1000Hz
- 1250Hz

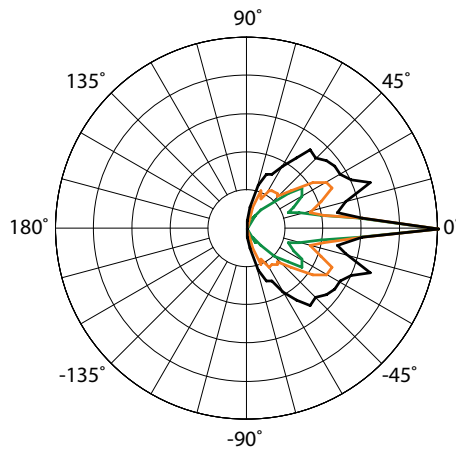

- 10000Hz
- 12500Hz
- 16000Hz

Anya Module Specifications

Vertical Polar Data, Adapted for 45° Vertical Pattern

See NOTES GRAPHIC DATA for details

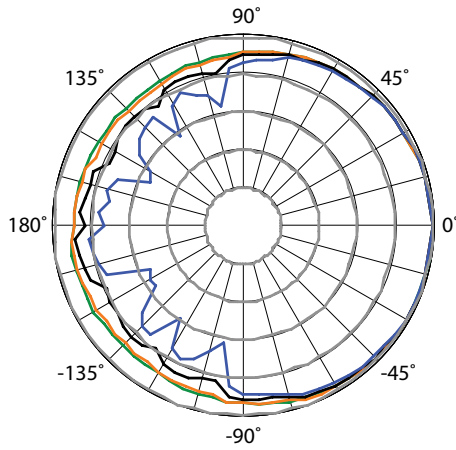

- 100Hz
- 125Hz
- 160Hz
- 200Hz

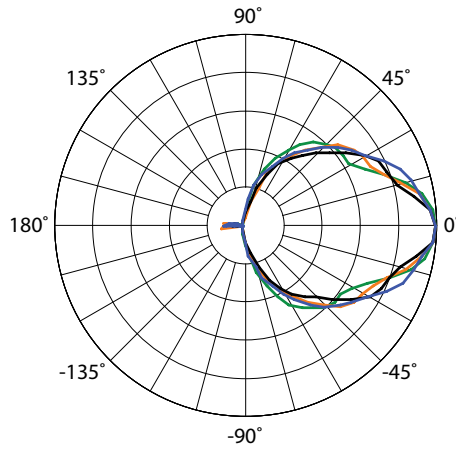

- 1600Hz
- 2000Hz
- 2500Hz
- 3150Hz

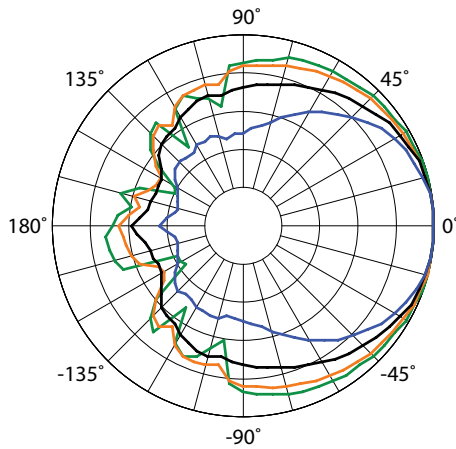

- 250Hz
- 315Hz
- 400Hz
- 500Hz

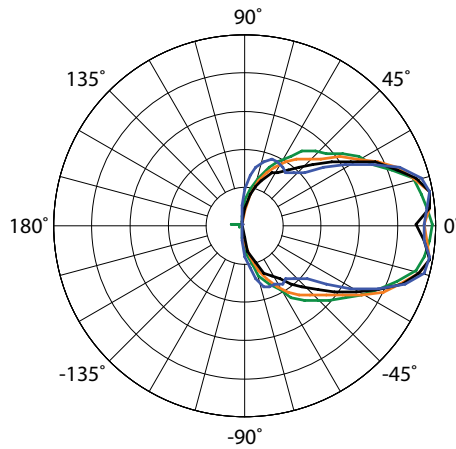

- 4000Hz
- 5000Hz
- 6300Hz
- 8000Hz

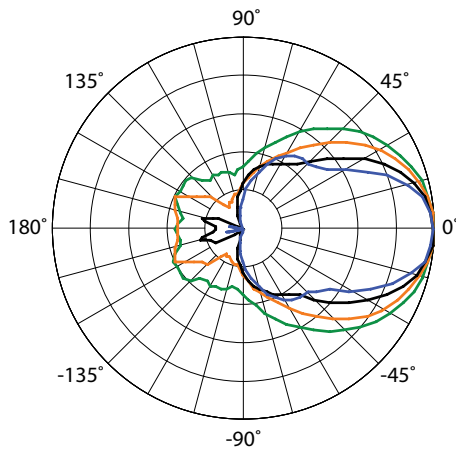

- 630Hz
- 800Hz
- 1000Hz
- 1250Hz

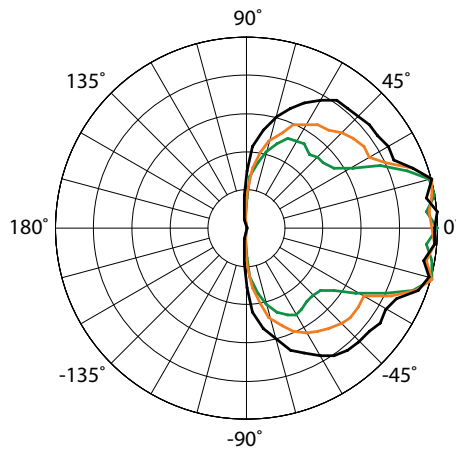

- 10000Hz
- 12500Hz
- 16000Hz



Anya Module Specifications

Vertical Polar Data, Adapted for 90° Vertical Pattern

See NOTES GRAPHIC DATA for details

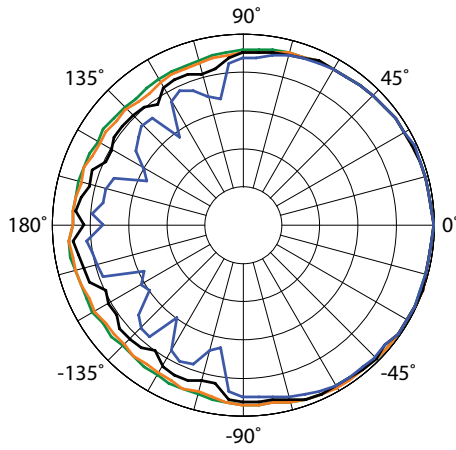

- 100Hz
- 125Hz
- 160Hz
- 200Hz

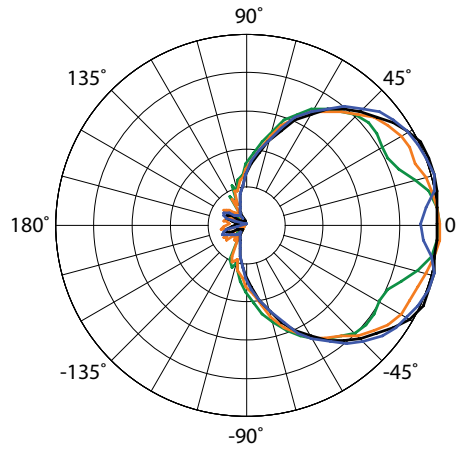

- 1600Hz
- 2000Hz
- 2500Hz
- 3150Hz

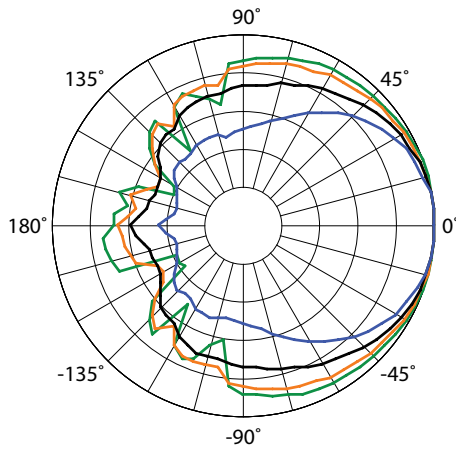

- 250Hz
- 315Hz
- 400Hz
- 500Hz

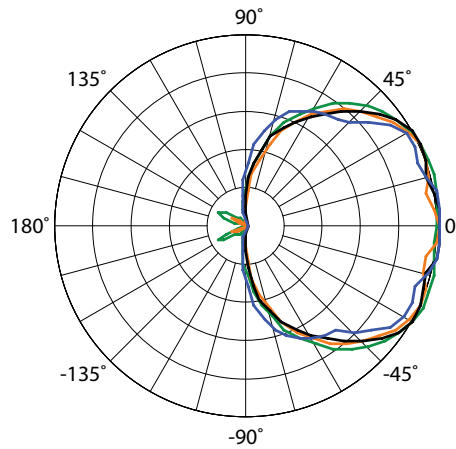

- 4000Hz
- 5000Hz
- 6300Hz
- 8000Hz

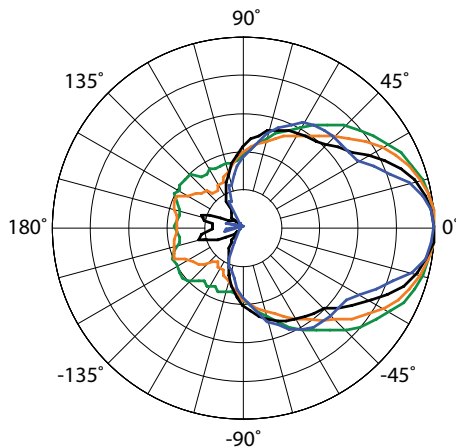

- 630Hz
- 800Hz
- 1000Hz
- 1250Hz

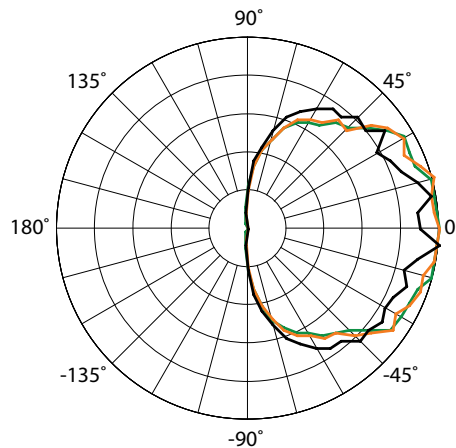

- 10000Hz
- 12500Hz
- 16000Hz

Anya Module Specifications

Input Panel



1. powerCON™ TRUE1™ AC Mains Input
2. USB Port Type B
3. USB Port Type A
4. Dual etherCON™ Connectors (redundant)
5. XLR Audio Input Connector
6. XLR Audio Loop-Through Connector
7. Network Activity Indicator
8. Device Test Key and Light
9. Input Type Indicator
10. Function Key and Light

Signal Diagram

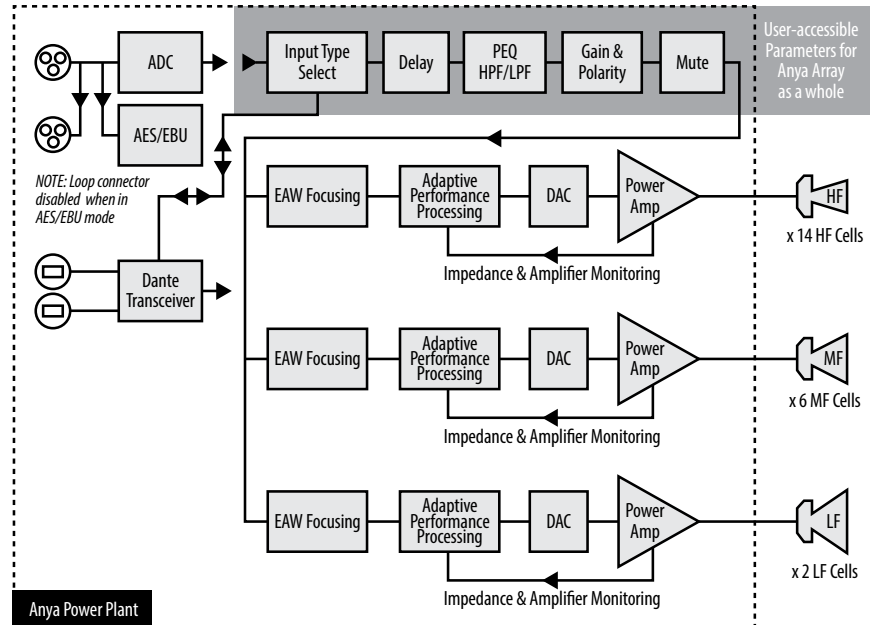

Legend

- HPF** High Pass Filter for crossover –or– Recommended High Pass Filter
- LPF** Low Pass Filter for crossover
- LF/MF/HF** Low Frequency / Mid Frequency / High Frequency
- AMP** User Supplied Power Amplifier –or– Integral Amplifier for NT products
- XVR** Passive LPFs, HPFs, and EQ integral to the loudspeaker
- EAW Focusing** Digital Signal Processor capable of implementing EAW Focusing

Notes

TABULAR DATA

1. **Measurement/Data Processing Systems:** Primary – FChart; proprietary EAW software; Secondary – Brüel & Kjær 2012.
2. **Microphone Systems:** Earthworks M30; Brüel & Kjær 4133
3. **Measurements:** Dual channel FFT; length: 32 768 samples; sample rate: 48 kHz; logarithmic sine wave sweep.
4. **Measurement System Qualification** (includes all uncertainties): SPL: accuracy +/-0.2 dB @ 1 kHz, precision +/-0.5 dB 20 Hz to 20 kHz, resolution 0.05 dB; Frequency: accuracy +/-1 %, precision +/-0.1 Hz, resolution the larger of 1.5 Hz or 1/48 octave; Time: accuracy +/-10.4 µs, precision +/-0.5 µs, resolution 10.4 µs; Angular: accuracy +/-1°, precision +/-0.5°, resolution 0.5°.
5. **Environment:** Measurements time-windowed and processed to eliminate room effects, approximating an anechoic environment. Data processed as anechoic or fractional space, as noted.
6. **Measurement Distance:** 7.46 m. Acoustic responses represent complex summation of the subsystems at 20 m. SPL is referenced to other distances using the Inverse Square Law.
7. **Enclosure Orientation:** For beamwidth and polar specifications, as shown in Mechanical Specification drawing.
8. **Volts:** Measured rms value of the test signal.
9. **Watts:** Per audio industry practice, "loudspeaker watts" are calculated as voltage squared divided by rated nominal impedance. Thus, these are not True Watt units of energy as defined by International Standard.
10. **SPL:** (Sound Pressure Level) Equivalent to the average level of a signal referenced to 0 dB SPL = 20 microPascals.
11. **Subsystem:** This lists the transducer(s) and their acoustic loading for each passband. Sub = Subwoofer, LF = Low Frequency, MF = Mid Frequency, HF = High Frequency.
12. **Operating Mode:** User selectable configurations. Between system elements, a comma (,) = separate amplifier channels; a slash (/) = single amplifier channel. DSP = Digital Signal Processor.
IMPORTANT: To achieve the specified performance, the listed external signal processing must be used with EAW-provided settings.
13. **Operating Range:** Range where the processed Frequency Response stays within -10 dB SPL of the power averaged SPL within this range; measured on the geometric axis. Narrow band dips are excepted.
14. **Nominal Beamwidth:** Design angle for the -6 dB SPL points, referenced to 0 dB SPL as the highest level.
15. **Axial Sensitivity:** Power averaged SPL over the Operating Range with an input voltage that would produce 1 W at the nominal impedance; measured with no external processing on the geometric axis, referenced to 1 m.
16. **Nominal Impedance:** Selected 4, 8, or 16 ohm resistance such that the minimum impedance point is no more than 20% below this resistance over the Operating Range.
17. **Accelerated Life Test:** Maximum test input voltage applied with an EIA-426B defined spectrum; measured with recommended signal processing and Recommended Protection Filter.
18. **Calculated Axial Output Limit:** Highest average and peak SPLs possible during the Accelerated Life Test. The Peak SPL represents the 2:1 (6 dB) crest factor of the Life Test signal.
19. **High Pass Filter:** This helps protect the loudspeaker from excessive input signal levels at frequencies below the Operating Range.

GRAPHIC DATA

1. **Resolution:** To remove insignificant fine details, 1/12 octave cepstral smoothing was applied to acoustic frequency responses and 1/3 octave cepstral smoothing was applied to the beamwidth and impedance data. Other graphs are plotted using raw data.
2. **Frequency Responses:** Variation in acoustic output level with frequency for a constant input signal. Processed: normalized to 0 dB SPL. Unprocessed inputs: 2 V (4 ohm nominal impedance), 2.83 V (8 ohm nominal impedance), or 4 V (16 ohm nominal impedance) referenced to a distance of 1 m.
3. **Processor Response:** The variation in output level with frequency for a constant input signal of 0.775 V = 0 dB reference.
4. **Beamwidth:** Average angle for each 1/3 octave frequency band where, starting from the rear of the loudspeaker, the output first reaches -6 dB SPL referenced to 0 dB SPL as the highest level. This method means the output may drop below -6 dB SPL within the beamwidth angle.
5. **Impedance:** Variation in impedance magnitude, in ohms, with frequency without regard to voltage/current phase. This means the impedance values may not be used to calculate True Watts (see 9 above).
6. **Polar Data:** Horizontal and vertical polar responses for each 1/3 octave frequency band 100 Hz to 16 kHz or Operating Range.