

# MK8100 Series

## 2-Way Full-Range Loudspeakers

- ▶ System includes an 8-in woofer and a 1-in exit/1.4-in voice coil compression driver on a CD horn
- ▶ Internal passive crossover/filter network allows powering by a single amp channel while smoothing power response
- ▶ Beamwidth optimized crossover points eliminate off-axis voids through crossover
- ▶ User-rotatable horn allows for "rotate the enclosure around the horn" option to mount vertically or horizontally

### OVERVIEW

The MK8100 two-way loudspeaker system sets the standard in installation performance by solving the chronic problems of compact two-way loudspeakers. Yet it's size is actually smaller than many of the compact two-ways it outperforms. The HF horn loading the 1-in exit/35mm voice coil compression driver is larger than most traditional compact two-way horns. This extends pattern control lower into the midrange than would otherwise be possible and allows the horn's pattern to overlap the woofer's pattern in the critical crossover area.

Advanced beamwidth matching crossover point selection transitions between the subsystems exactly where the HF horn's coverage pattern matches the woofer's pattern. This eliminates the beamwidth mismatch that creates off axis voids in the crossover area of traditional two-way systems. The internal passive crossover/filter network uses complex, asymmetrical slopes to integrate the subsystems and goes beyond merely dividing the signal to perform critical equalization functions.

MK8196z

▶ 90° x 60°

MK8126i

▶ 120° x 60°



### TECHNOLOGIES



**Beamwidth Matched Crossovers** Introduced over a decade ago for our MK series loudspeakers, EAW Engineers use carefully-designed HF horns and crossovers to eliminate polar irregularities through the crossover point.



**Focusing™** Use of advanced digital signal processing to perfect the impulse response of a loudspeaker in the time domain. Eliminating horn "honk" and splashiness, this makes the loudspeaker sound like a studio monitor instead of a "PA" speaker.



**DynO™** Dynamic Optimization actively tracks input spectrum and power delivery, continually wicking maximizing output and fidelity at any drive level.

## TECHNICAL SPECIFICATIONS

### 2-WAY FULL-RANGE LOUDSPEAKERS

PERFORMANCE	MK8196Z	MK8126I
<b>Max SPL<sup>1</sup></b> (12 dB Crest Factor)	130 dB	
<b>Max SPL<sup>1</sup></b> (6 dB Crest Factor)	124 dB	
<b>Operating Range<sup>2</sup></b>	65Hz - 19kHz	
<b>Nominal Beamwidth<sup>3</sup></b>	90° Horizontal x 60° Vertical	120° Horizontal x 60° Vertical
<b>Nominal Phase</b>	±15° from ideal high-pass filter	
<b>Input Impedance</b>	LF/HF=8Ω	
ACCELERATED LIFE TEST <sup>4</sup>		
<b>LF/HF</b>	49v	300W
CONFIGURATION		
<b>LF Transducer, Loading</b>	1 x 8in Cone, 2in Voice Coil, Vented	
<b>HF Transducer, Loading</b>	1 x 1in Exit, 1.4in Voice Coil Compression Driver, Horn Loaded	
<b>Operating Modes</b>	Passive	
PHYSICAL		
<b>Dimensions</b> (HxWxD)	19.75in H x 11.75in W x 11.03in D (501.7 mm H x 298.5mm W x 280.1mm D)	
<b>Net Weight</b>	30 lbs (13.6kg)	
<b>Shipping Weight</b>	36 lbs (16.3kg)	
<b>Mounting Accessories</b>	U-Bracket	
<b>Input Connector</b>	NL4 x 2, Barrier Strip	

1 Calculated max SPL at 1m with 4:1 pink noise. Specified as whole space (free field) for full range loudspeakers, half space for subwoofers.

2 Operating Range: Range where the processed Frequency Response stays within -10 dB SPL of the power averaged SPL within this range; measured on the geometric axis. Narrow band dips are excepted.

3 Nominal Beamwidth: Design angle for the -6 dB SPL points, referenced to 0 dB SPL as the highest level.

4 Axial Sensitivity: Power averaged SPL over the Operating Range with an input voltage that would produce 1 W at the nominal impedance; measured with no external processing on the geometric axis, referenced to 1 m.

INPUT PANEL

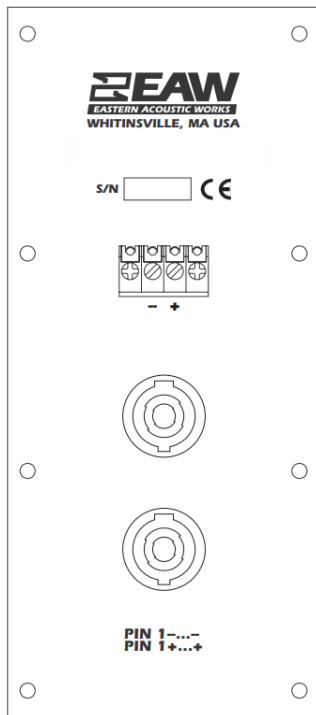

SIGNAL DIAGRAM

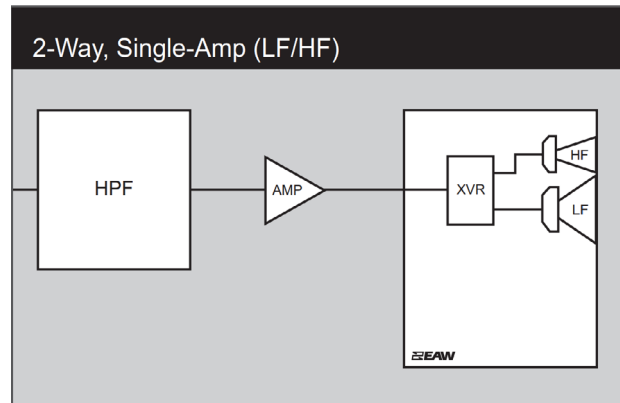

LEGEND

- DSP:** User-supplied Digital Signal Processor.
- HPF:** High Pass Filter for crossover or Recommended High Pass Filter.
- LPF:** Low Pass Filter for crossover.
- LF/MF/HF:** Low Frequency / Mid Frequency / High Frequency.
- AMP:** User-supplied Power Amplifier.
- XVR:** Passive LPFs, HPFs, and EQ integral to the loudspeaker.

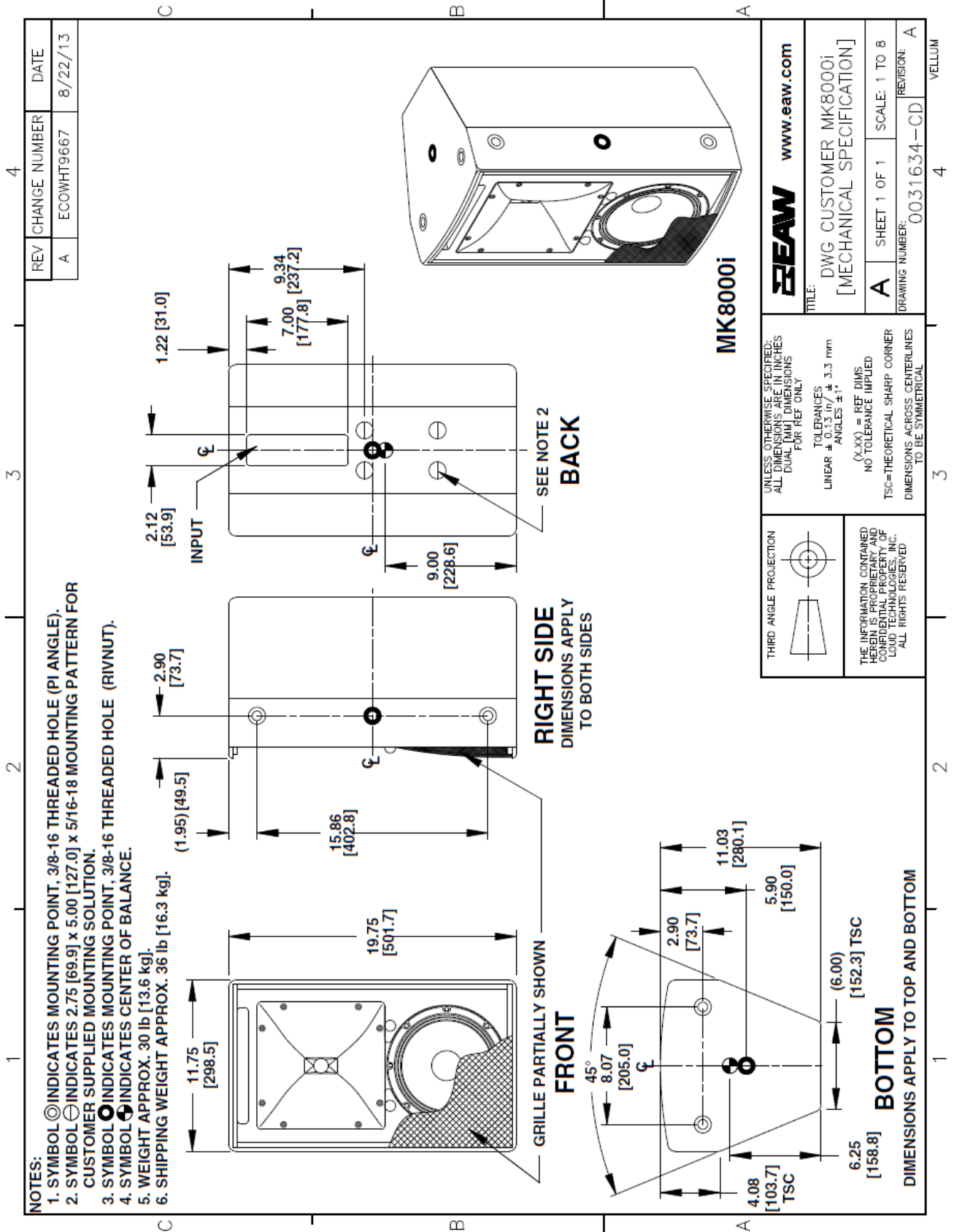

PERFORMANCE GRAPHS

Frequency Response(Unprocessed)

Frequency Response(Processed)

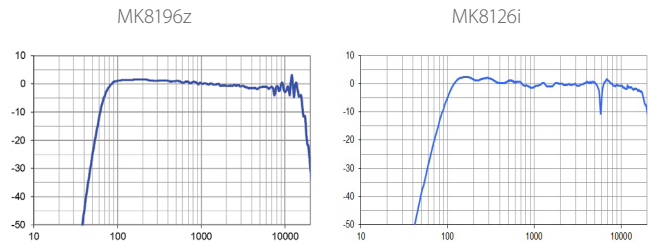
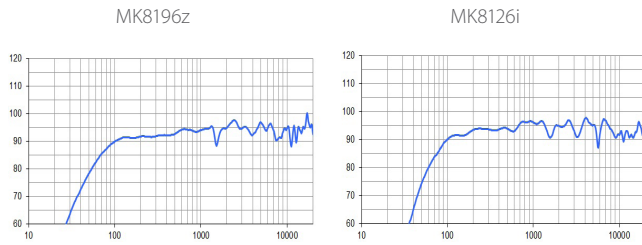

Phase Linearity

Impedance

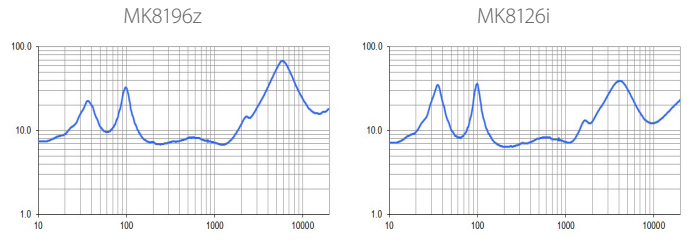
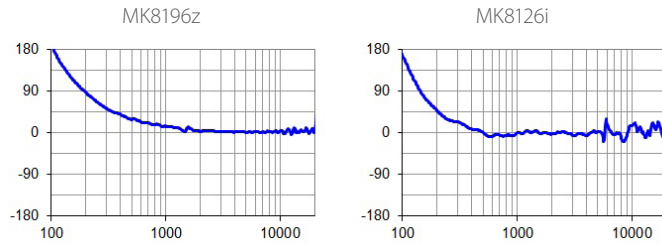

Beamwidth<sup>1</sup> ■=Vertical ■=Horizontal

