

VMA CONTRACTOR SERIES MIXER-AMPLIFIERS

Cloud
CONTRACTOR SERIES

MODELS: VMA120, VMA240

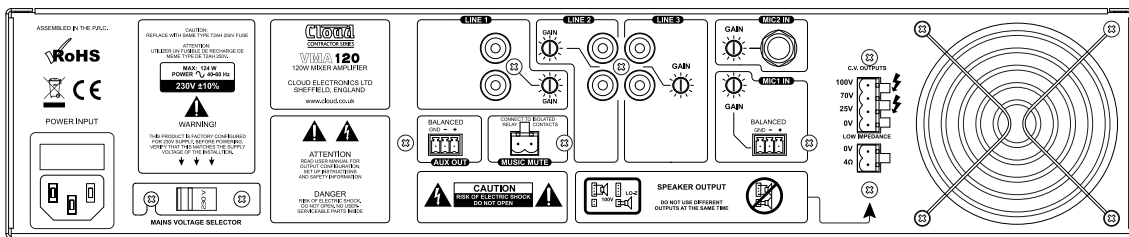
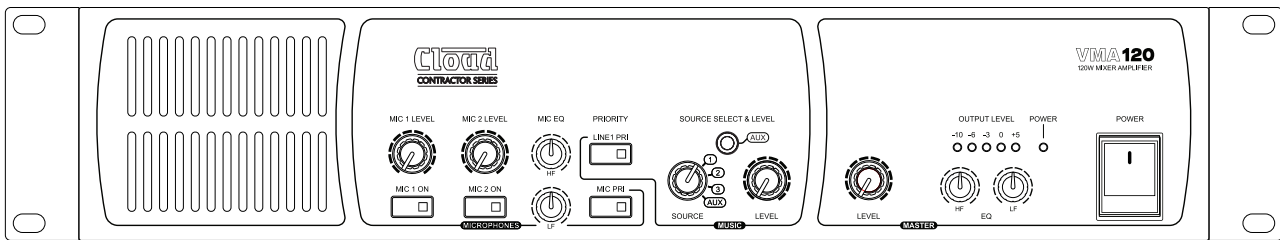

VMA120 illustrated: Model VMA240 is identical

General Description

The Cloud VMA120 and VMA240 are cost-effective mixer-amplifiers for use in all types of commercial premises. They have been designed to be as simple to install and operate as possible, but offer a useful range of features and configuration options.

The units are mono power amplifiers combined with a simple mixer stage. The two models are identical in terms of facilities, and differ only in the maximum power output available – 120 W or 240 W respectively. They may be used to drive either low-impedance loudspeakers directly (4 ohms minimum) or 25/70/100 V-line loudspeaker distribution systems. The two different types of speaker system cannot be driven simultaneously. A high-pass filter, selectable by internal jumper, minimises the effect of transformer saturation at low frequencies when driving 25/70/100 V-line systems.

The units have four stereo line inputs (typically for connection of music sources), including an AUX input in the form of a 3.5 mm jack socket on the front panel to permit the easy connection of laptops, tablets and similar devices. Two balanced microphone inputs are also provided: phantom power is available at each, selectable by internal jumper. A high-pass filter for each mic input may also be selected by internal jumper: this reduces the effects of handling and breath noise. All mic and line inputs (except the AUX input) have a preset-type gain control adjacent to the input connectors on the rear panel.

The front panel has rotary controls for line input selection, music level, the level of each mic input, and LF/HF EQ adjustment for the summed mic inputs. Two switches enable priority options: one allows the mic inputs to have priority over music sources to permit announcements, the other gives one line input priority over all others: this is useful for connecting a jukebox or message store, for example. Two further switches enable/disable each mic input. The front panel controls also include a master level control and HF/LF EQ adjustment for the main output.

The rear panel has a music mute control input which can be used to mute all music sources in an emergency: an internal jumper allows this to also mute the mic inputs if wished. There is also a balanced auxiliary output to allow additional power amplifiers to be slaved.

VMA Series: main features:

- Industrial quality mixer-amplifiers
- Power output: 120 W/channel (VMA120) or 240 W/channel (VMA240)
- Outputs suitable for either low-impedance (min. 4 ohm) or 25/70/100 V-line systems
- Four stereo unbalanced line inputs (3 x RCA jack pairs, 1 x 3.5 mm TRS jack on front panel)
- Rear panel line inputs have individual gain controls
- Two balanced mic inputs (1 x multipin connector, 1 x 1/4" TRS jack), with individual preset gain controls
- Front panel controls for mic and music levels, line input selection, mic EQ, master level and EQ
- Mic input mute switches on front panel
- Line 1 priority, enabled by front panel switch
- Mic-over-music priority, enabled by front panel switch
- 15 V phantom power available at either mic input (selected by internal jumper)
- 100 Hz high-pass filter on each mic input (selected by internal jumper)
- 70 Hz high-pass filter in output stage, for use with 25/70/100 V-line systems
- Fixed limiter – prevents clipping
- Front panel LED bargraph – indicates output signal level
- Over-temperature and output DC protection
- 230 V or 115 V operation
- Forced-air cooling

Block Diagram

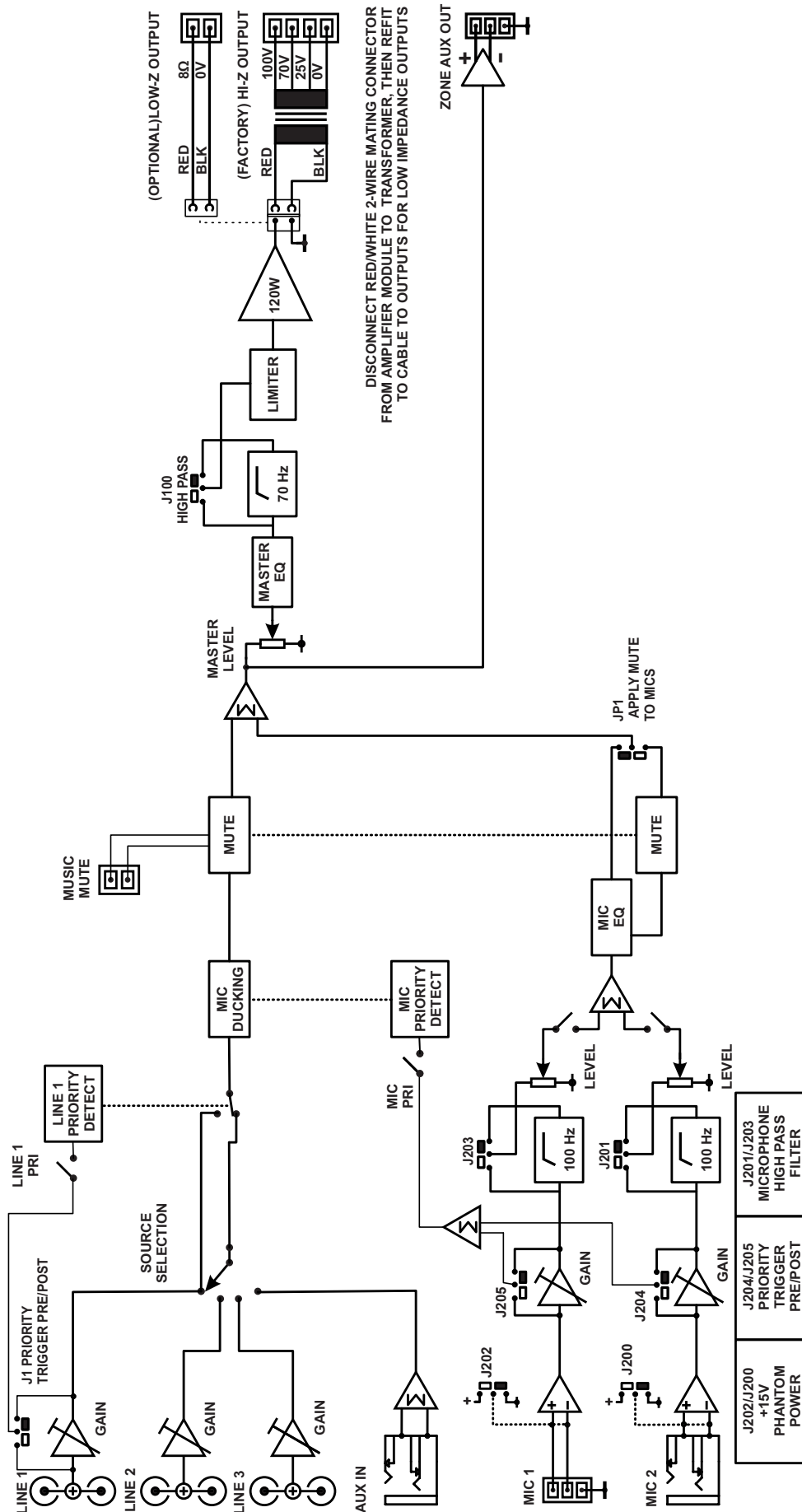

Technical Specifications

Line Inputs				
Frequency Response	20 Hz to 20 kHz, ± 1 dB			
Gain range	0 dBu to +20 dBu			
Input impedance	47 kohms			
Noise	<-82 dB (22 kHz bandwidth)			
Equalisation	LF: ± 10 dB @ 50 Hz HF: ± 10 dB @ 10 kHz			
Microphone Inputs				
Frequency Response	-3 dB @100 Hz (fixed filter) to 20 kHz, ± 1 dB			
Gain range	2.45 mV (-50dBu) to 245 mV (-10 dBu)			
Input Impedance	3.3 kohms (balanced)			
Phantom Power	15 V, switchable per-input by jumpers			
Noise (EIN)	-125 dBu (20 Hz to 22 kHz bandwidth, max gain, $R_s = 150$ ohms)			
Equalisation	LF: ± 10 dB @ 100 Hz; HF: ± 10 dB @ 5 kHz			
Main Output				
Output Power (1 kHz continuous sine wave)	VMA120	120 watts		
	VMA240	240 watts		
Minimum load	Low-Z output	4 ohms		
	High-Z output	25 V-line	VMA120	5.2 ohms
			VMA240	2.6 ohms
		70 V-line	VMA120	41 ohms
			VMA240	20 ohms
		100 V-line	VMA120	83 ohms
VMA240			41 ohms	
Frequency response	Low-Z output	20 Hz to 20 kHz, ± 1 dB		
	High-Z output	20 Hz to 20 kHz, ± 1 dB (70 Hz filter off)		
THD + N	< 0.08% @ 1 kHz			
Protection	Fixed level signal limiter: DC and over-temperature protection			
Auxiliary Output				
Nominal output level	0 dBu (0.775 Vrms), balanced			
Noise	<-82 dB, 22 kHz bandwidth			
General				
Power input	Selectable 115 VAC or 230 VAC, $\pm 10\%$; 45 – 65 Hz			
Fuse details	5 x 20 mm, time delay	230 V models	2 A	
		115 V models	4 A	
Normal operating temperature	0 °C to 35 °C (Note: performance and specifications cannot be guaranteed outside of this range)			
Cooling	Forced air cooling, 80 mm dia. fan; airflow front-to-back			
Power Consumption	Idle ²	VMA120	13.5 W (19.2 VA)	
		VMA240	15.5 W (20.5 VA)	
	1/8 th Power ³	VMA120	88.6 W (119.7 VA)	
		VMA240	188.5 W (251.3 VA)	
	1/3 rd Power ⁴	VMA120	136.5 W (177.7 W)	
		VMA240	252.1 W (330 VA)	
Heat Loss	Idle ²	VMA120	48.7 KJ/hr (46.1 BTU/hr)	
		VMA240	55.8 KJ/hr (52.9 BTU/hr)	
	1/8 th Power ³	VMA120	276 KJ/hr (262 BTU/hr)	
		VMA240	548 KJ/hr (519 BTU/hr)	
	1/3 rd Power ⁴	VMA120	407 KJ/hr (386 BTU/hr)	
		VMA240	665 KJ/hr (630 BTU/hr)	
Dimensions (W x H x D)	Net	482.6 mm x 88 mm (2U) x 267 mm 19" x 3.5" (2U) x 10.5"		
	Shipping (Gross)	535 mm x 185 mm x 350 mm 21.1" x 7.3" x 13.8"		
Weights	Net	VMA120	7.9 kg / 17.7 lbs	
		VMA240	9.6 kg (22.2 lbs)	
	Shipping (Gross)	VMA120	8.7 kg / 19.5 lbs	
		VMA240	10.5 kg (23.5 lbs)	

Notes re Power Consumption and Heat Loss measurements:

All measurements at 230 VAC 50 Hz power input

1. Idle: amplifier active, but no audio output
2. 1/8th. Power: constant sound level at one-eighth maximum rated output per channel (audio mainly clean, only occasional clipping)
3. 1/3rd. Power: constant sound level at one-third maximum rated output per channel (audio beginning to become compressed, limited or heavily clipped)

Dimensions

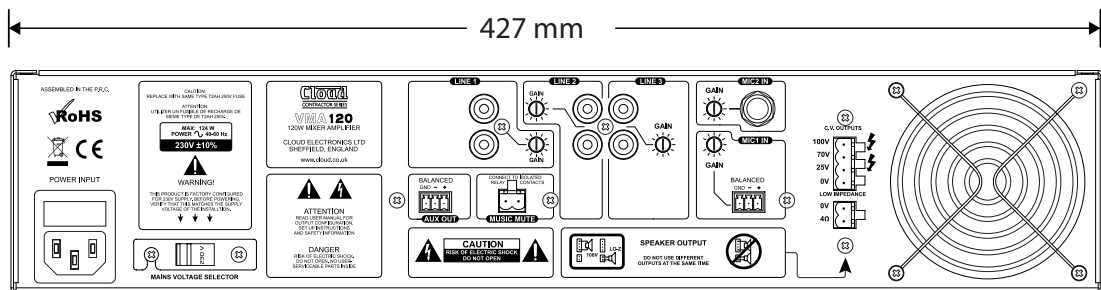
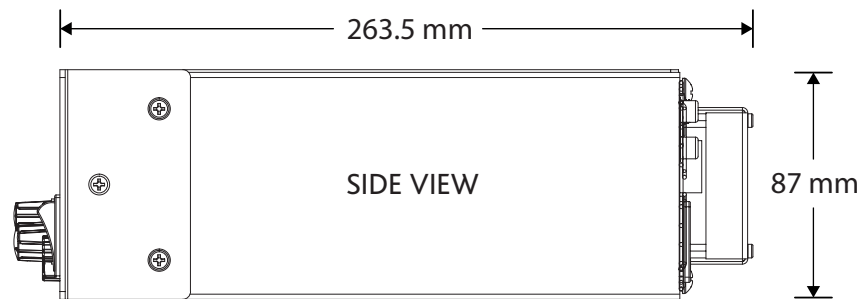
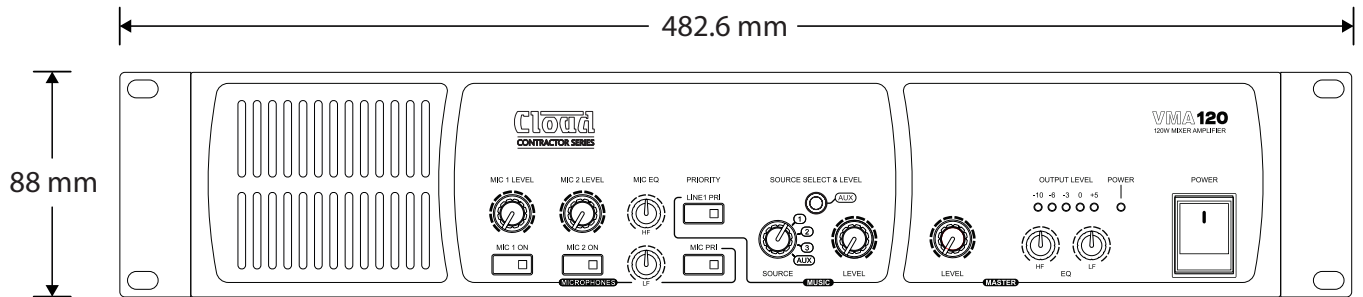

Performance Graphs

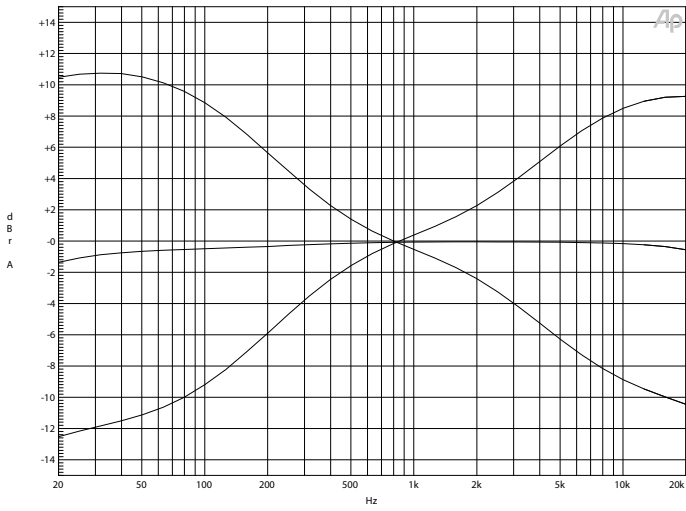

Main EQ

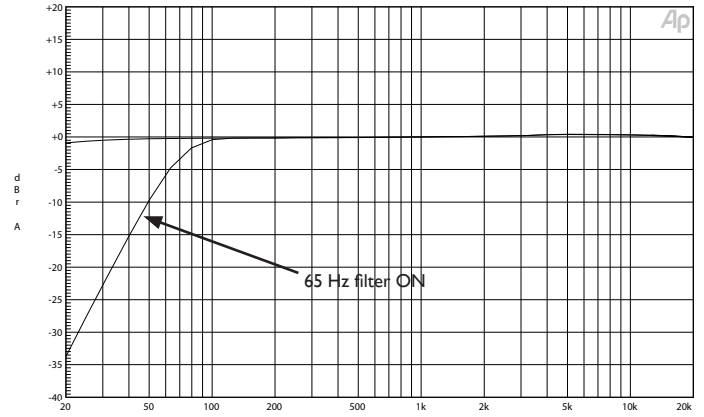

Frequency response

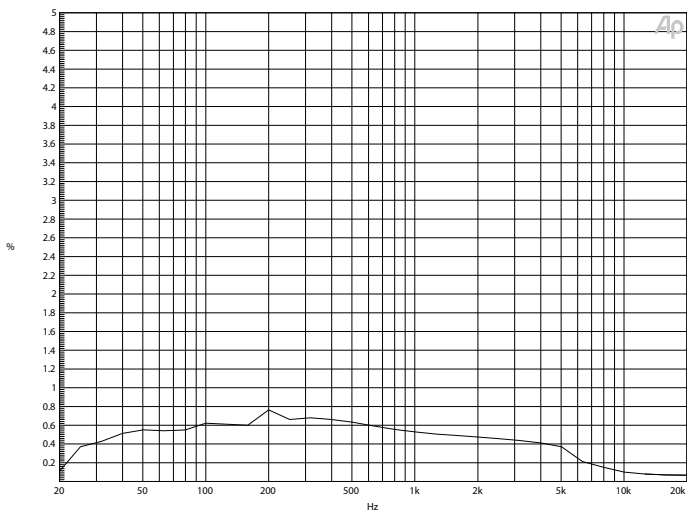

THD + Noise

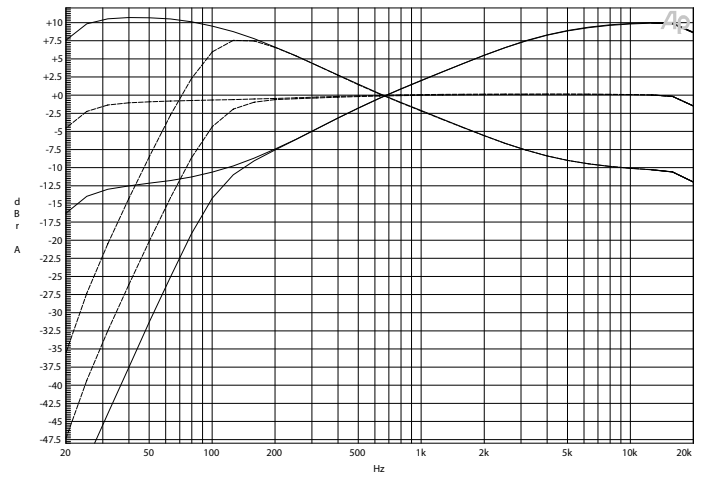

Mic frequency response

Architect's and Engineer's Specification

The mono mixer-amplifier shall be equipped with four unbalanced stereo music inputs: three of these shall be on phono sockets (RCA jacks) and one on a 3.5 mm 3-pole jack socket which shall be accessible from the front of the unit. The mixer-amplifier shall have two balanced microphone inputs on detachable multipin connectors. The music input to be used shall be selected by a four-position front panel rotary switch. The two mic inputs shall be mixed to a mono signal and summed with a mono (L+R) sum of the selected music input. Each mic input shall have its own front panel level control. It shall be possible to control the level of the music source independently of the mic levels. Each music input and each mic input shall also have a rear panel gain control: the front panel music input need not meet this requirement. Two-band equalisation adjustment shall be provided on the front panel for the summed microphone signals. The front panel shall also be provided with a master level control and two-band equalisation: these controls shall affect the final mixed output. Visual indication of output signal level shall be provided on the front panel by not less than five LEDs: the LEDs indicating the two highest levels shall be orange and red, the remainder shall be green.

15 V phantom power shall be available at each microphone input: this shall be selectable for each input by moving internal PCB jumpers. Each microphone input shall have a simple high-pass filter to remove frequencies below 100 Hz: this shall be selectable for each input by moving internal PCB jumpers. Each microphone input shall be provided with a front panel switch to enable/disable the input: the switch shall be internally illuminated when the mic input is active.

Front panel switches shall configure the mixer-amplifier to perform the following functions: i) detection of a signal on any mic input will automatically reduce the music level by approximately 30 dB, ii) detection of a signal at one line input will automatically override all others, even if unselected. The switches shall be internally illuminated when the priority function is enabled. An external control input shall be provided to allow muting of the music source by a fire alarm or other external emergency system. It shall be possible to additionally mute the microphone inputs by this command input by moving an internal PCB jumper.

The mixer-amplifier shall be available in two models with different output powers of 120 W or 240 W, measured into a four ohm load. The mixer-amplifier shall be capable of driving either low impedance (four ohms or higher) loads, or 100 V-line, 70 V-line or 25 V-line line systems via an internal transformer fitted as standard. It shall not be possible to use both types of output simultaneously. The 100 V, 70 V and 25 V transformer outputs shall be available on a rear panel output connector of the detachable multipin type, shrouded by a screw-attached safety cover. The low impedance output shall be available on a separate detachable multipin connector.

A switchable high-pass filter shall be fitted to each channel to remove LF content below 70 Hz (-3 dB) to minimise transformer saturation in 100/70/25 V-line systems; this filter shall be by-passable by moving an internal jumper. A fixed limiter circuit shall operate in such a manner that it is not possible for clipping to occur in the output stage. The amplifier shall also incorporate protection circuitry that isolates the output in the event of DC being detected at the amplifier output or if the internal temperature exceeds a safe operating level.

The mixer-amplifier shall be equipped with a balanced line level output from the pre-amplifier stages: this shall use a detachable multipin connector on the rear panel.

The mixer-amplifier shall be built in a 2U steel chassis for mounting in a standard 19" rack. Temperature-controlled forced-air fan cooling with front-to-rear airflow shall be employed. The front panel shall be fitted with a mechanically latching mains power switch and there shall be visual indication of the amplifier's active status.

It shall be possible to specify either version of the amplifier to operate from an AC mains supply voltage of 115 V or 230 V, with a tolerance of +/-10% applying to both voltages.

The mixer-amplifiers shall be the Cloud VMA120 (120 W output) and the Cloud VMA240 (240 W output).
