

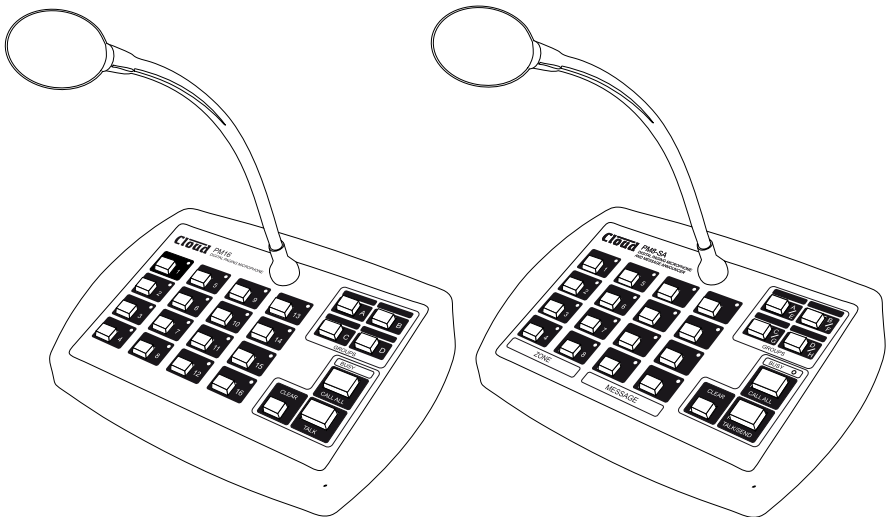

# PM Series Digital Paging Microphones

PM4, PM8, PM12, PM16  
PM4-SA, PM-8SA (with Message Announcer)



## Installation and User Guide



**PM4/8/12/16**  
**PM4-SA, PM-8SA**  
**Digital Paging Microphones**

# CONTENTS

PM4/8/12/16 .....	3
PM4-SA, PM-8SA.....	3
Digital Paging Microphones .....	3
<b>Introduction .....</b>	<b>6</b>
Safety Information.....	6
Conformities.....	6
Overview .....	7
Scope of this manual .....	8
What's in the box .....	9
Controls and connections .....	10
Front Panels .....	10
PM (non-SA).....	10
PM-SA .....	10
Rear Panel .....	11
PM (all models) .....	11
<b>Spot Announcer (SA) Models .....</b>	<b>11</b>
Memory cards .....	12
Sound files - types .....	12
Filenames .....	13
General Dos and Don'ts .....	14
Paging one or more zones.....	14
Paging all zones.....	15
Paging a Zone Group.....	15
Announcement Interruption (Multiple PM systems only) .....	15
<b>Using the PM (SA models) - User Instructions .....</b>	<b>16</b>
General Dos and Don'ts .....	16
Paging one or more zones .....	16
Paging all zones .....	17
Sending a pre-recorded message to one or more zones .....	17
Sending a pre-recorded message to all zones .....	17
Paging a zone group – groups A to D .....	18
Paging a zone group – groups E to H (Model PM-8SA only) .....	18
Sending a pre-recorded message to a zone group – groups A to D .....	18
Sending a pre-recorded message to a zone group – groups E to H (Model PM8-SA only) .....	19
Cancelling a message .....	19
Announcement Interruption (Multiple PM systems only) .....	19

<b>Installation .....</b>	<b>20</b>
Accessing the internal PCB .....	20
Mounting Options .....	20
Free-standing .....	20
Wall Mounting.....	21
Power Requirements .....	22
Using an External PSU.....	22
Powering standard (non-SA) models from a Cloud host mixer .....	24
Powering SA models from a Cloud Digital Paging Interface ..	27
Cables and Connections .....	29
Connecting the PM to a mixer via the digital interface.....	29
Connecting the PM to a mixer via the analogue interface.....	30
Connecting a PM-SA for external message triggering .....	33
Configuring the PM .....	35
Zone Groups.....	35
Setup options .....	37
Message chimes .....	42
Systems with multiple paging microphones.....	47
<b>Appendix.....</b>	<b>52</b>
PCB layout diagrams .....	52
Jumper and default settings summary – standard (non-SA) models.....	53
Jumper and default settings summary – SA models only .....	55
Technical Specifications .....	56

## INTRODUCTION

### Safety Information

Cloud PM paging microphones operate from a low DC voltage, supplied by either an AC adaptor or the Cloud host device to which the microphone is connected. As such, the microphone requires few safety precautions.

However, note that both the metal base of the unit and the mic gooseneck will be electrically connected to the chassis of the host device (e.g., Cloud zoner or mixer/amplifier) once the installation is carried out. This means that if the mains wiring of the host device and/or the building is faulty, the microphone could present a shock hazard. Fitting a suitable earth leakage circuit breaker (e.g., 30 mA RCD type) to the mains supply of the host device can provide additional protection.

### Conformities

This product conforms to the following European EMC Standards:

**BS EN 55103-1:2009**

**BS EN 55103-2:2009**

This product has been tested for use in commercial and light industrial environments. If the equipment is used in controlled EMC environments, the urban outdoors, heavy industrial environments or close to railways, transmitters, overhead power lines etc., the performance of the unit may be degraded.

This product conforms to the following European electrical safety Standard:

**BS EN 60065:2002**

## Overview

Thank you for purchasing this Cloud PM paging microphone.

Six models of the PM are available:

- The PM4, PM8, PM12 and PM16 are Digital Paging Microphones able to page to 4, 8, 12 or 16 zones respectively.
- The PM4-SA and PM8-SA are Digital Paging Microphones with built-in Message Announcer capability. They can page, or send messages to 4 or 8 zones respectively.

Physically, the PM4, PM8, PM12 and PM16 differ only in the number of zone select buttons on the front panel, and consequently in the maximum of zones supported. The PM4-SA is similar in operation to the PM4, but the front panel has an additional 4 buttons for the Message Announcer feature, and thus resembles the PM-8 in appearance. Similarly, the PM8-SA has 8 more buttons than the PM8, and thus resembles the PM16 in appearance.

PM models include the following basic features:

- Individual and multiple zone selection for both paging and messages (messages apply to SA models only)
- External NC/NO message triggering (SA models only)
- Definable zone groups with group selection
- 'TALK' ('TALK/SEND' on SA model) and 'CALL ALL' buttons
- Pre-paging chime with internal chime sounder
- 'BUSY' LED
- Configurable two-layer paging priority system
- Auto zone reset after paging and zone disable
- Suitable for free-standing or wall mounted operation

The PM is designed to interface directly with several Cloud products - such as the DCM-1, Z4/Z8MK4 and 46-120 - via the Cloud Digital Paging Interface, which uses standard CAT-5 cable and RJ45 connectors. It is also provided with an "analogue" interface, permitting it to be used with any other audio system equipped with 'short-to-ground' paging access for selecting the zone(s) to be paged. This includes the following current\* Cloud products:

- CX163 Mixer
- CX263 Mixer
- 36-50 Integrated Mixer Amplifier

\*Other, older Cloud products may also be compatible; please contact Cloud's Technical Department for advice.

Multiple PMs may be interconnected (via the Digital Paging Interface) to permit paging from more than one location. A total cable run of up to 1 km is permissible, with a maximum of 32 PM units. Different models of PM may be intermixed on a single network. It is also possible to configure a PM to address only a subset of the available zones.

The PM is also compatible with the older Cloud CDPM range of digital paging microphones. PM microphones and CDPM microphones may be freely intermixed on the Digital Paging Interface.

## Scope of this manual

The bulk of this manual is intended to guide you through the installation and configuration of the PM. Sections of the manual cover aspects such as power requirements, connecting the unit to various types of host mixer, and configuring the PM to suit the particular requirements of the installation. These sections will be adequate for situations where there is only a single PM. A separate section covers the various additional points that need to be considered when multiple PMs are interconnected on a network.

The manual covers both standard PM microphones and the SA models, which include a digital sound store for pre-recorded messages. The installation and operation of the two models is similar in many respects; nevertheless there are some important differences between the models. These include the additional wiring needed if the stored messages are to be triggered externally, and the internal PCB layout and jumper locations.

The sections of the manual which are specific to the PM4/8-SA are clearly indicated by the use of this icon 



Wherever the term “PM” is used in this manual, the text can be taken to apply to all models (both SA and non-SA) of the microphone. Similarly, the term ‘TALK’ can be taken to correspond with the term ‘TALK/SEND’ on the SA model.

The procedures for mounting a PM on a wall and changing the standard gooseneck mic for a shorter one are also described.

In addition to the installation aspects, a User Section includes a simplified description of the PM's operation; it is recommended that installers should photocopy this section (or download a PDF copy of this manual from the Cloud website and print the section off), and leave a copy for the operator.



## What's in the box

- Model PM paging microphone
- Installation and User Guide (this manual)
- Foam pop-shield for mic
-  SA models only: AC power supply unit
-  SA models only: 1 GB SD memory card\* pre-loaded with:
  - Sample chime MP3 files
  - 'Readme' text document about recording messages and chimes
  - PDF version of this manual

\*Installed inside microphone

If any items are received in a damaged state or are missing from the packaging, please contact your Cloud dealer/distributor at once. Wherever possible, please retain the packaging until the microphone is satisfactorily installed and working, in case it needs to be returned to the factory.

## Controls and connections

### Front Panels

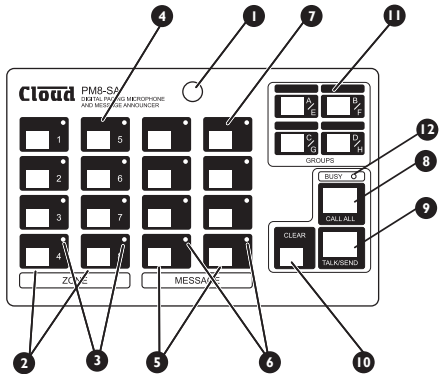
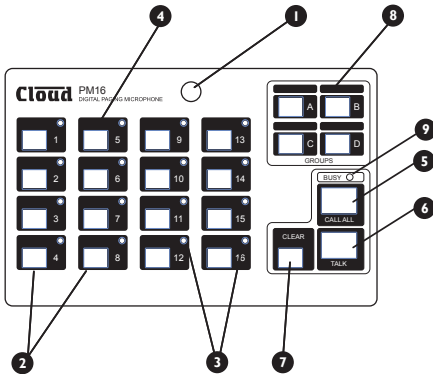

#### PM (non-SA)

1. Gooseneck microphone
2. ZONE selection buttons
3. ZONE select LEDs
4. Legend areas for zone identification
5. CALL ALL button
6. TALK button
7. CLEAR button
8. GROUP select buttons
9. BUSY LED

#### PM-SA

1. Gooseneck microphone
2. ZONE selection buttons
3. ZONE select LEDs
4. Legend areas for zone identification
5. MESSAGE selection buttons
6. MESSAGE active LEDs
7. Legend areas for message names
8. CALL ALL button
9. TALK/SEND button
10. CLEAR button
11. GROUP select buttons
12. BUSY LED

## Rear Panel

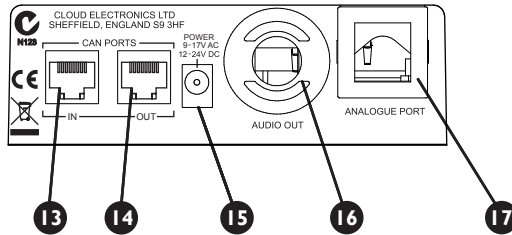

### PM (all models)

- 13. Digital Paging Interface IN
- 14. Digital Paging Interface OUT
- 15. External power input
- 16. Access gland for audio output cable
- 17. Access gland for analogue control cable(s)

## SPOT ANNOUNCER (SA) MODELS

PM Models PM4-SA and PM8-SA have identical paging microphone functions to the PM4 and PM8, but also include Spot Announcer capability. Up to four (PM4-SA) or eight (PM8-SA) pre-recorded messages can be stored internally on a standard SD memory card. As well as the messages, up to four (PM4-SA) or eight (PM8-SA) pre-announcement chimes can be stored on the same card. An SD card is supplied with each PM-SA unit, containing pre-recorded sample chime files.

The SD card is plugged into a dedicated card slot, accessed through the baseplate of the unit.

A selection of commonly-used, pre-recorded messages is available to download from [www.cloud.co.uk](http://www.cloud.co.uk).

## Memory cards

SA models of the PM accept standard SD cards with a capacity of up to 2 GB or SDHC cards up to 32 GB. MiniSD/MiniSDHC or MicroSD/MicroSDHC cards can also be used with the appropriate adapter, up to the same maximum capacities.

To access the memory card slot, first disconnect the PM from its power supply source (if necessary) according to the powering method - by unplugging the external PSU, the Digital Paging Interface CAN OUT connector, or by turning off the host mixer. Invert the unit and undo the two pan-head hex-socket screws securing the card slot cover with a 2 mm hex key.

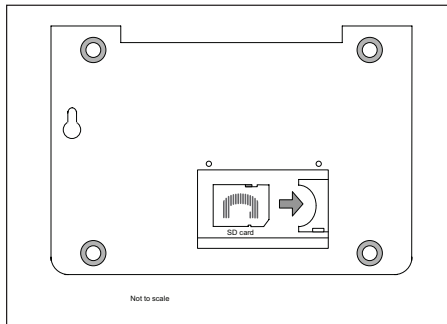

Insert the card oriented as shown (pins away from you), and slide into the card holder as far as it will go.

## Sound files - types

The PM-SA is able to play sound files recorded in either MP3 or WMA (Windows Media Audio) format, of the following types:

- MP3 files - MPEG 1/2/2.5 layer2/3 decoding, data rate 32 kbps ~ 320 kbps, including VBR
- WMA files - WMA format, data rate 32 kbps ~ 384 kbps
- Sampling frequencies supported: 8 kHz, 11.025 kHz, 12 kHz, 16 kHz, 22.05 kHz, 24 kHz, 32 kHz, 44.1 kHz or 48 kHz

Announcement and chime sound files should be prepared on a computer (with an SD card slot), and then saved to the card with the filenames given in the following section. Files may be of any duration, but please see the section “Message/chime duration and message cancellation” on page 42. Note that the write-protection tab must be in the ‘unlocked’ position when files are being copied to the card. Set the tab to ‘lock’ before inserting the card in the PM’s card slot.

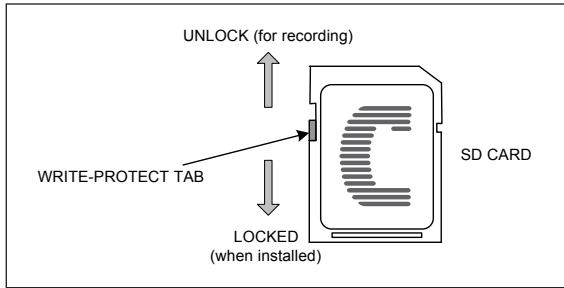

## Filenames

SA models of the PM will recognise files of the above types with the following filenames:

Message files: `M_x.mp3` or `M_x.wma`

Chime files: `C_x.mp3` or `C_x.wma`

In both the message and chime filenames, *x* must have a value between 1 and 8. Thus valid message filenames are `M_1.mp3` to `M_8.mp3`, and valid chime filenames are `C_1.mp3` to `C_8.mp3` (or their `*.wma` equivalents). All other files on the memory card will be ignored.

The sound file `M_1.mp3` (or `M_1.wma`) will be played when MESSAGE button 1 is pressed; the remaining sound files correspond numerically to the other buttons in exactly the same way.

The sound file `C_1.mp3` (or `C_1.wma`) is always used as the pre-announcement page chime. Pre-recorded messages may be preceded by either `C_1.mp3` or `C_2.mp3` (or their `*.wma` equivalents). Additionally, any chime file may be assigned to a zone group to precede a pre-recorded message. See “Chime settings – SA models only” on page 41 for details of how to configure chime settings, and “Assigning a chime to a zone group (SA models only)” on page 36 for details of chime assignment to zone groups.

Filenames `M_5.mp3` to `M_8.mp3` and `C_5.mp3` to `C_8.mp3` (or their `*.wma` equivalents) will be ignored by a PM4-SA.

Note that all chime and message files must be saved in the memory card’s root directory. The PM-SA cannot play sound files located within folders.

## USING THE PM (NON-SA MODELS) - USER INSTRUCTIONS

*To the installer: please photocopy pages 14 & 15 and leave with the customer.*

### General Dos and Don'ts

When making an announcement:

- Think what you need to say before making the announcement.
- Speak slowly and clearly in a normal speaking voice.
- Don't "swallow" the microphone; unless you are in a particularly noisy environment your mouth need be no closer than 4 - 5 inches (10 – 12 cm) from the mic.
- Don't start speaking before you press the TALK button, and then wait until the pre-announcement chime (if active) has sounded in full before starting.
- Don't release the TALK button until the announcement is finished.
- Don't twist the gooseneck into odd shapes – it isn't a toy!

### Paging one or more zones

1. Press the ZONE button(s) for the zone(s) to which the announcement is to be made; the LEDs corresponding to the selection will illuminate. (An incorrect selection may be cancelled with the CLEAR button.)
2. To start announcing, press and hold down the TALK button (the BUSY LED illuminates).
3. Make the announcement.
4. Zones may be selected/deselected while the TALK button is pressed.
5. When the announcement is finished, release the TALK button.

**NOTE:** Once the talk button is released, the zone selection may either automatically clear or remain set for further announcements, depending on how the unit was configured at installation. If it remains set, it may be cleared by pressing the CLEAR button.

## Paging all zones

1. Press and hold the CALL ALL button; all the LEDs for enabled zones and the BUSY LED will illuminate.
2. Make the announcement.
3. Zones may be selected/deselected during the announcement.
4. When the announcement is finished, release the CALL ALL button.

## Paging a Zone Group

1. Press the GROUP button for the required zone group. (The zone LEDs corresponding to the zones defined for the group will illuminate.)
2. Press and hold down the TALK button.
3. Make the announcement.
4. Zones may be added/removed during the announcement. (NOTE - this is only “per-announcement”; it does not alter the group definition).
5. Release the TALK button.

## Announcement Interruption (Multiple PM systems only)

If the system has more than one PM microphone, it is possible that announcements may be attempted from different microphones simultaneously. Priority assignments made during the system installation can prevent two microphones on the network from making an announcement at the same time. You may therefore find that your announcement is temporarily overridden by another announcement, from a PM with higher priority.

If your announcement conflicts with one from a higher priority microphone, yours will be cut off and the interrupting announcement will take over. The interrupted PM will indicate this condition by the ZONE LEDs flashing. The selection LEDs will remain lit so that you can make your announcement again once the system is free.

## USING THE PM (SA MODELS) - USER INSTRUCTIONS

*To the installer: please photocopy pages 16 to 19 section and leave with the customer.*

### General Dos and Don'ts

When making an announcement:

- Think what you need to say before making the announcement.
- Speak slowly and clearly in a normal speaking voice.
- Don't "swallow" the microphone; unless you are in a particularly noisy environment your mouth need be no closer than 4 - 5 inches (10 – 12 cm) from the mic.
- Don't start speaking before you press the TALK/SEND button, and then wait until the pre-announcement chime (if active) has sounded in full before starting.
- Don't release the TALK/SEND button until the announcement is finished.
- Don't twist the gooseneck into odd shapes – it isn't a toy!
- Familiarise yourself with the contents of the pre-recorded messages – sending the wrong one can be embarrassing!

### Paging one or more zones

1. Press the ZONE button(s) for the zone(s) to which the announcement is to be made; the LEDs corresponding to the selection will illuminate. (An incorrect selection may be cancelled with the CLEAR button.)
2. To start announcing, press and hold down the TALK/SEND button (the BUSY LED illuminates).
3. Make the announcement.
4. Zones may be selected/deselected while the TALK/SEND button is pressed.
5. When the announcement is finished, release the TALK/SEND button.

**NOTE:** Once the talk button is released, the zone selection may either automatically clear or remain set for further announcements, depending on how the unit was configured at installation. If it remains set, it may be cleared by pressing the CLEAR button.



## Paging all zones

1. Press and hold the CALL ALL button; all the LEDs for enabled zones and the BUSY LED will illuminate.
2. Make the announcement.
3. Zones may be selected/deselected during the announcement.
4. When the announcement is finished, release the CALL ALL button.

## Sending a pre-recorded message to one or more zones

1. Press the ZONE button(s) for the zone(s) to which the message is to be sent; the LEDs corresponding to the selection will illuminate. (An incorrect selection may be cancelled with the CLEAR button.)
2. Press the MESSAGE button for the required pre-recorded message; the associated LED will illuminate to confirm selection.
3. To broadcast the message, press and release the TALK/SEND button. The BUSY LED will illuminate for the duration of the message.
4. Zones may be selected/deselected during the message.

**NOTE:** Once the message is finished, the zone and message selections may either clear or remain set for further use, depending how the unit was configured at installation. If they remain set, they may be cleared by pressing the CLEAR button.

NOTE: The microphone is disabled for the duration of a pre-recorded message, so you cannot make an announcement at the same time as broadcasting a message.

## Sending a pre-recorded message to all zones

1. Press the MESSAGE button for the required pre-recorded message; the associated LED will illuminate to confirm selection.
2. To broadcast the message, press and release the CALL ALL button; the LEDs for enabled zones and the BUSY LED will illuminate.
3. Zones may be selected/deselected during the message.
4. When the announcement is finished, the BUSY LED will go out.

## Paging a zone group – groups A to D

1. Press the GROUP button for the required zone group. (The zone LEDs corresponding to the zones defined for the group will illuminate.)
2. Press and hold down the TALK/SEND button.
3. Make the announcement.
4. Zones may be added/removed during the announcement. (NOTE - this is only 'per-announcement'; it does not alter the group definition).
5. Release the TALK/SEND button.

## Paging a zone group – groups E to H (Model PM-8SA only)

1. 'Double-click' the GROUP button for the required zone group. (The zone LEDs corresponding to the zones defined for the group will illuminate.)
2. Press and hold down the TALK/SEND button.
3. Make the announcement.
4. Zones may be added/removed during the announcement. (NOTE - this is only 'per-announcement'; it does not alter the group definition).
5. Release the TALK/SEND button.

## Sending a pre-recorded message to a zone group – groups A to D

1. Press the GROUP button for the required zone group. (The zone LEDs corresponding to the zones defined for the group will illuminate.)
2. Press the MESSAGE button for the required pre-recorded message; the associated LED will illuminate to confirm selection.
3. To broadcast the message, press and release the TALK/SEND button. The BUSY LED will illuminate for the duration of the message.
4. Zones may be selected/deselected during the message.

## **Sending a pre-recorded message to a zone group – groups E to H (Model PM8-SA only)**

1. 'Double-click' the GROUP button for the required zone group. (The zone LEDs corresponding to the zones defined for the group will illuminate.)
2. Press the MESSAGE button for the required pre-recorded message; the associated LED will illuminate to confirm selection.
3. To broadcast the message, press and release the TALK/SEND button. The BUSY LED will illuminate for the duration of the message.
4. Zones may be selected/deselected during the message.

## **Cancelling a message**

If the microphone has been enabled for message cancellation, pressing CLEAR while a message or pre-message chime is sounding will cancel the operation.

## **Announcement Interruption (Multiple PM systems only)**

If the system has more than one PM microphone, it is possible that announcements or message broadcasts may be attempted from different microphones simultaneously. Priority assignments made during the system installation can prevent two microphones on the network from making an announcement or sending a message at the same time. You may therefore find that your announcement or message is temporarily overridden by another announcement or message, from a PM with higher priority.

If your announcement or message conflicts with one from a higher priority microphone, yours will be cut off and the interrupting announcement or message will take over. The interrupted PM will indicate this condition by the ZONE LEDs flashing. The selection LEDs will remain lit so that you can make your announcement, or broadcast your message again once the system is free.

## INSTALLATION

### Accessing the internal PCB

With most installations, it will be necessary at some point to access the PM's internal PCB. Access is required to make connections to the analogue interface (possibly including DC power connections) and to connect the associated audio output, to move the various configuration jumpers, to adjust the mic or chime levels and, on the SA models, to connect to the external message trigger inputs, if used.

The standard (non-SA) and SA models of the PM are fitted with different PCBs, but the housing and method of access are the same. Refer to "PCB layout diagrams" on page 52 for PCB layout diagrams showing locations of jumpers, pre-set controls, connectors and other primary PCB items.

To gain access to the PCB, first disconnect any source of external power (e.g., a local external PSU or the Digital Paging Interface). Then remove the five pozidrive screws securing the bottom cover plate onto the moulded housing. Gently lift the housing free, noting that the PCB to which the top panel components are mounted is connected to the lower PCB by a ribbon cable. Take care not to stretch or snag either this or the cable from the gooseneck mic. The ribbon cable may be unplugged from the PCB to give easier access to the board, if wished.

Re-assembly is the reverse procedure; always use the same screws.

### Mounting Options

In most cases, the PM will be used as a desk-top, free-standing unit. In situations where desk space is at a premium, or where access to the microphone needs to be restricted, an alternative mounting method is to fix it on a vertical surface such as a wall. In this case, it may be appropriate to fit a shorter gooseneck mic, as the standard one (300 mm) may prove awkward in use and possibly constitute a hazard.

### Free-standing

No special provisions are needed to use the PM in a free-standing mode. Cable access is via the rear glands and the unit is provided with four rubber feet to prevent slipping on a polished surface. The standard 300 mm gooseneck microphone will be suitable for all normal desk or counter locations.

## Wall Mounting

NOTE: if the standard gooseneck mic is to be replaced with the shorter alternative (see “Fitting the M1100166 gooseneck microphone” on page 22), perform the replacement before mounting the PM on the wall.

The metal baseplate of the PM is fitted with two keyhole slots which provide a simple method of wall mounting.

The PM can be wall-mounted on two round-head or pan-head screws with heads of between 5 and 10 mm dia. At the desired location, drill two holes in the wall 183 mm apart horizontally. Use a drill appropriate for the wall construction and type of wall fixing employed. Insert the screws and tighten until approx 4-5 mm of the screw shafts are still visible. Slide the PM over the screw heads using the keyhole slots, so that the rubber feet act as spacers between the PM baseplate and the wall. If the PM is not tight against the wall, remove the PM, adjust the length of screw protruding and try again. Repeat until a good tight fit is obtained. Refer to the illustration below for drilling instructions.

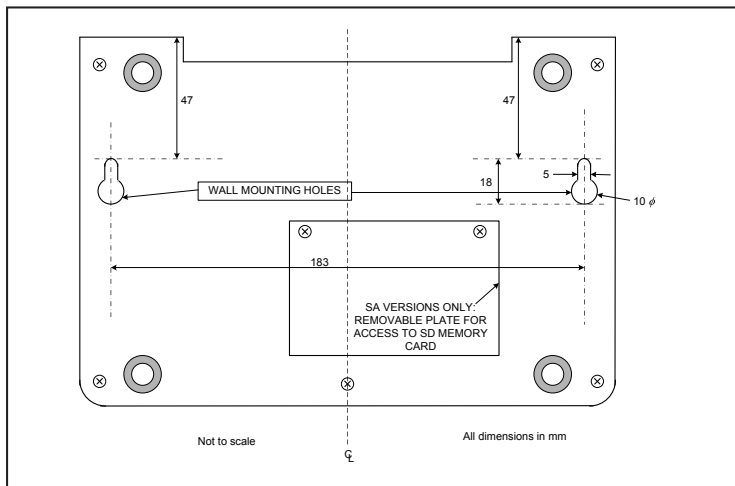

## Fitting the MII00166 gooseneck microphone

The standard gooseneck mic supplied with the PM Series is 300 mm in length, and this may be inconveniently long if the PM unit is wall-mounted. A 140 mm version, Part No. MII00166, may be ordered separately from Cloud Electronics, and fitted instead.

To replace the gooseneck mic, remove the baseplate of the PM unit as detailed at “Accessing the internal PCB” on page 20. It will be seen that the thin twin-and-screen cable from the gooseneck itself terminates in a screw terminal connector on the right-hand side of the PCB (see “PCB layout diagrams” on page 52 for location of this connector). (Note that this connector is also used for the internal chime speaker.) Disconnect the gooseneck by undoing the three relevant screw terminals on the connector.

The gooseneck itself may now be removed by undoing the 14 mm nut securing it to the casing – a box spanner is the best tool for this.

Fitting the MII00166 gooseneck assembly is the reverse procedure. Fit the gooseneck first and tighten the securing nut; then reconnect the twin-and-screen cable to the connector block, observing the polarities shown on the PCB silk-screening adjacent to the connector. Then replace the baseplate.

## Power Requirements

The standard (non-SA) PM can be powered either by an external PSU, or from a Cloud host mixer.

☐ SA models of the PM can be powered either by the external PSU supplied with the unit, or from a Cloud DCM-I Digitally Controlled Mixer. They cannot be powered from other Cloud host mixers such as the Z4II/Z8II or 46/50. If using a PM-SA with these mixers, it must be powered by the supplied PSU.

## Using an External PSU

An external power supply can be connected to the PM via the 2.1 mm coaxial power socket on the rear panel. A suitable external PSU is the Cloud CPM-PSU; one is supplied with each SA model, but may otherwise be obtained from Cloud Electronics. Other AC or DC external supplies can be used with PMs, provided they are capable of providing 107 mA (non-SA models), or 250 mA (SA models) at 9-17V AC or 12-24V DC.

**IMPORTANT:** Many DC adapters have poor regulation, and some nominally 24V supplies can produce voltages sufficiently high to cause damage to the internal electronics. If in doubt, use a 12V AC adapter such as the CPM-PSU.

As the PM incorporates a full-wave rectifier circuit internally, the polarity of the 2.1mm jack is unimportant.

**IMPORTANT:** The external power supply should not have one side of its output earthed, as this may introduce earth loops to the system. Most - but not all - plug-top adapters meet this requirement, but installers should check for earth-to-output continuity with a test meter if there is any doubt. The integrity of the system's mains earth should NEVER be compromised to meet this requirement, or to solve an earth loop problem.

## Powering standard (non-SA) models from a Cloud host mixer

If the PM is to be connected to a Cloud host mixer, DC power may be obtained from the mixer as long as it has a suitable power supply connection, and the spare current capacity of the mixer is sufficient. As a general rule, a mixer cannot supply power to a PM that has more zones than itself.

Note that if the PM is being powered from a host mixer, an external PSU should not be simultaneously connected; in this case, the external PSU will override the current draw from the host, and it will power the microphone instead.

There are two ways in which a PM can be supplied with DC power by a Cloud host mixer:

1. Via the Digital Paging Interface. The CAN PORT OUT connector on the PM is wired for power, so a PM connected to a Cloud host mixer fitted with the Digital Paging Interface can obtain power through this connection. In systems with multiple, "daisy-chained" PMs, it is only the "last" PM on the network - i.e., that connected directly to the host - which can be powered in this way. See "Systems with multiple paging microphones" on page 47 for more information.
2. Note that when using the Digital Paging Interface, the maximum recommended cable length between the Cloud host mixer and the "last" PM should not exceed 50 m. If longer cable lengths are required, then an external PSU should be connected to the PM.
3. Via the Analogue Port. The PM's analogue interface allows for DC power. The '+V' and '0V' terminals of the internal port connector should be wired to the '+V' and '0V' pins respectively of the access connector at the Cloud host mixer. This method of powering requires an additional core in the access cable (the '0V' connection will need to be made in any case for the zone selection to function). Only one microphone may be powered from the mixer in this way. The wiring diagram on page 32 illustrates this connection.



## Current considerations

The table below gives the current required by the various PM models:

PM Model	Required Current
PM4	72 mA
PM8	83 mA
PM12	95 mA
PM16	107 mA

The following table shows spare DC current available from various Cloud host mixers, etc., for powering additional items:

Host	Available Current
DCM-1/DCM-1e	650 mA
Z4MK4	350 mA
Z8MK4	350 mA
CX163	Use ext. PSU
CX263	Use ext. PSU
36-50	Use ext. PSU
46-120	240 mA

These figures apply to the host units without any active options installed, such as internal loudspeaker EQ cards or remote plates. These options all consume power, so the available current may be insufficient to power the PM. In such cases, an external PSU must be used.

The table below lists the current taken by various Cloud options which may be installed in the host mixer (figures are per item; those for EQ cards are per-channel):

Option	Required Current
<b>Active Remote Plates</b>	
LM-2	25 mA
DM-I	18 mA
BE-I	24 mA
LE-I	22 mA
ME-I	43 mA
<b>DCM-I Remote Control Plate</b>	
CDR-I(F)	50 mA
<b>Bose® EQ Modules*</b>	
BEQ: M8, M32, MA12, 402, 502A, 802, MB4, MB24, 502B, 502BEX	12 mA
BEQ: LT3202, LT4402, LT9402, LT9702	17 mA
BEQ: M16, DS100, DS16, M1B	34 mA
<b>Amina EQ Modules*</b>	
EQ-AIWX	9 mA
EQ-LFIT	12 mA
<b>Soundtube EQ modules*</b>	
RS4-EZ	12 mA
RS500i, RS400i	9 mA
RS100i	6 mA

The installer should check what options (if any) are fitted, and de-rate the “Available Current” figure accordingly before checking if the host has sufficient spare current capacity to power the PM.

\*Note that in the case of the DCM-I, fitting loudspeaker EQ modules does not reduce the current available from the host.

## Powering SA models from a Cloud Digital Paging Interface

SA models of the PM may be powered from a host unit which is fitted with a Cloud Digital Paging Interface. Examples are the DCM-I/DCM-Ie, Z4MK4 and Z8MK4 and 46-120. Other (mainly older) Cloud host mixers, such as the Z4MK3/Z8MK3 or 36-50, have insufficient spare current capacity to power SA models of the PM.

Note that if the PM is being powered from a Cloud Digital Paging Interface, an external PSU should not be simultaneously connected.

Host units with the Digital Paging Interface will have adequate spare current capacity to power external accessories, but bear in mind that the maximum available current will be reduced if active remote control or input modules are also connected. The table below lists the current taken by various accessories which may be connected to the DCM-I/DCM-Ie (figures are per module):

Option*	Required Current
<b>Active Remote Plates</b>	
BE-I	24 mA
LE-I	22 mA
ME-I	43 mA
<b>Remote Control Plate</b>	
CDR-I(F)	50 mA

\*Fitting loudspeaker EQ modules to the DCM-I does not de-rate its external current capability.

Please consult the Installation and User Guides for other host models for the corresponding figures for the relevant accessories.

To summarise, there are two ways in which a PM-SA can be supplied with DC power by a Cloud host unit equipped to support paging microphones:

1. Via the Digital Paging Interface, where one is fitted. The CAN PORT OUT connector on the PM-SA is wired for power, so a PM connected via this can obtain power through the interface. In systems with multiple, "daisy-chained" PM-SAs (or PMs), it is only the 'last' PM/PM-SA on the network - i.e., that connected directly to the host - which can be powered in this way. See "Systems with multiple paging microphones" on page 47 for more information. Note that when using the Digital Paging Interface, the maximum recommended cable length between the host and the 'last' PM should not exceed 50 m. If longer cable lengths are required, then an external PSU should be connected to the PM.
2. Via the analogue interface. The PM-SA's analogue interface allows for DC power. The '+V' and '0V' terminals of the internal connector TERMI should be wired to the '+V' and '0V' pins respectively of the access connector of the host unit. This method of powering requires an additional core in the access cable (the '0V' connection will need to be made in any case for the zone selection to function). Only one microphone may be powered from the host in this way.

# Cables and Connections

## Connecting the PM to a mixer via the digital interface

The rear of the PM is fitted with two RJ45 sockets labelled CAN PORTS. These constitute the Cloud Digital Paging Interface, which connect the PM to the host mixer, and/or to other PMs on a network in a multiple-PM system. Where a mixer has facility for both digital and access contact connection, the digital connection should be used.

The digital interface carries audio from the mic and (on SA models only) the message stores, commands for zone selection and DC power on a single RJ45 connector. The audio signal is directional, and is transmitted from the OUT connector to the IN connector on the next microphone (or mixer) in the chain.

To connect the PM to a Cloud host mixer via the Digital Paging Interface, connect the OUT port of the PM to the IN port of the mixer using CAT-5 cable and RJ45 connectors. The cables should be wired pin-to-pin. The standard CAT-5/RJ45 wiring convention is shown below:

PIN	CAT-5 CORE
1	White + Orange
2	Orange
3	White + Green
4	Blue
5	White + Blue
6	Green
7	White + Brown
8	Brown

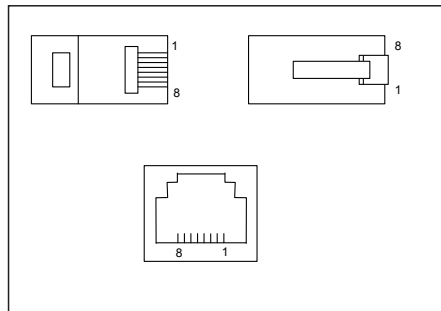

The IN port will only be used when the system has more than one PM. To interconnect two PMs, connect the OUT port of one to the IN port of the next 'in the chain' using the same wiring standard as shown in the table above. See "Systems with multiple paging microphones" on page 47 for full details.

A system using the Digital Paging Interface should have a total cable length of less than 1 km.

**IMPORTANT:** The Digital Paging Interface is a data network, and thus must be terminated at both ends. In a system comprising a single PM, this means terminations must be set in both the PM and the host mixer. In systems with multiple PMs, it means terminations must be set in the PM at the ‘end’ of the chain and the host mixer. See “Terminating the Digital Paging Interface” on page 45 for details of how to set terminations.

**NOTE:** If the Digital Paging Interface is used as the method of connecting the PM to the host mixer, the two access glands at the rear of the unit for the audio output and analogue control cables (see “Rear Panel” on page 11) will not be required.

## Connecting the PM to a mixer via the analogue interface

In addition to the Digital Paging Interface, the PM incorporates an analogue interface, permitting the PM to be used with any Cloud (or other) mixer which has an industry-standard, short-to-ground access port for zone selection.

The connections for the analogue interface are on the internal PCB. Follow the instructions on “Accessing the internal PCB” on page 20 on how to access this. Two cables are required. The two cables are as follows:

### 1. Audio Cable:

The audio cable should be a standard two-core, screened microphone cable. This cable should be fed through the rear cable gland labelled AUDIO OUT, and connected to the screw-terminal block marked TERM8 on the internal PCB. Refer to “PCB layout diagrams” on page 52 for location.

Connect to TERM8 as follows:

Terminal	Use	Typical Cable Colour
Hot	Phase (+)	Red
Cold	Anti-phase (-)	Black
Gnd	Screen	Screen

## 2. Zone Selection Control Cable:

The zone selection control cable should be a multicore stranded type with an overall screen. The number of cores required depends on the number of zones supported by the particular PM model (PM4, PM8, etc.), and whether DC power is to be derived from the host mixer via the control cable (see “Power Requirements” on page 22). One core is required for each zone to be connected, plus a core for the 0V connection, plus one further core for DC power, if needed.

The control cable should be fed through the rear cable gland marked ANALOGUE PORT, and connected to TERM1, TERM2 and TERM4 as detailed below:

Function	Connect To:	Function	Connect To:
Zone 1 Select	TERM2: Z1	Zone 10 Select	TERM4: Z10
Zone 2 Select	TERM2: Z2	Zone 11 Select	TERM4: Z11
Zone 3 Select	TERM2: Z3	Zone 12 Select	TERM4: Z12
Zone 4 Select	TERM2: Z4	Zone 13 Select	TERM4: Z13
Zone 5 Select	TERM2: Z5	Zone 14 Select	TERM4: Z14
Zone 6 Select	TERM2: Z6	Zone 15 Select	TERM4: Z15
Zone 7 Select	TERM2: Z7	Zone 16 Select	TERM4: Z16
Zone 8 Select	TERM2: Z8	0V	TERM1: 0V
Zone 9 Select	TERM4: Z9	+V	TERM1: +V

Cable core colours will depend on cable type.

Refer to “PCB layout diagrams” on page 52 for locations of TERM1, TERM2 and TERM4.

The cable screen should be connected to 0 V at the mixer end only. The analogue control cable should have a total length of less than 100 m.

When all the connections have been correctly made, and, in the case of an SA model, if an external message triggering cable is not required, tighten the locking clamps on the two cable glands to ensure that no strain is placed on the terminals if the external cables are tugged or stretched.

## Typical example

The diagram below shows the overall cable connections between a PM4 and a Cloud 46-50 host mixer (which has a typical 4-zone short-to-ground access port).

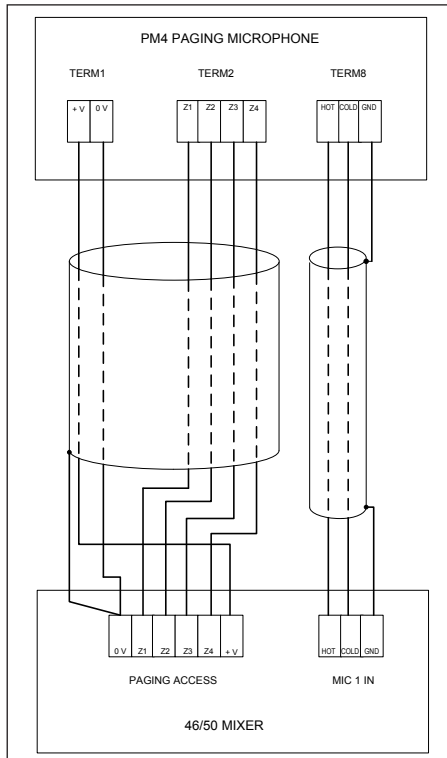

Note in this example that as Zones 5-16 are not in use, no connections need to be made to Z5-Z8 on TERM2, or to Z9-Z16 on TERM4.



## Connecting a PM-SA for external message triggering:

These connections are optional, and will only be required if the PM-SA's internal messages are to be triggered by external contact closure. Examples of such applications include:

- Programmed triggering via relays in external control systems (e.g., Crestron, AMX, etc.)
- Timed triggering by third-party timing equipment to broadcast messages at regular intervals
- Interface to BMS or fire control panels
- Automatic triggering by PIR sensors for security purposes
- Use of PIR sensors to provide promotional or other information
- Connection to door access systems to provide visitor information

Providing connections for external triggering of the messages does not prevent messages from being commanded by the PM's own front panel buttons; these continue to operate as normal.

The message trigger control cable may be a screened or unscreened multicore cable with a number of cores suitable for the number of messages to be externally triggered. UTP or STP data cable (i.e., CAT-5) is suitable. One core should be used as a 0V common connection for all the trigger inputs, or an overall screen may be used. The control cable should be fed through the rear cable gland marked ANALOGUE PORT (which it will have to share with an external zone select cable if an analogue mixer interface is in use), and connected to the 9-way PCB screw terminal block marked TERM10/TERM11/TERM12, as detailed below:

Function	Connect To:
0V	TERM10/11/12: 0V
Trigger Group A	TERM10/11/12: M1
Trigger Group B	TERM10/11/12: M2
Trigger Group C	TERM10/11/12: M3
Trigger Group D	TERM10/11/12: M4
Trigger Group E	TERM10/11/12: M5
Trigger Group F	TERM10/11/12: M6
Trigger Group G	TERM10/11/12: M7
Trigger Group H	TERM10/11/12: M8

The external message trigger inputs should ideally be connected to volt-free switch or relay contacts, which may be either NO (normally-open) or NC (normally-closed). This choice is set by moving J20, J21, and, (on the PM8-SA only), J22. The three jumpers allow selection of NO or NC independently for: M1 and M2; M3 and M4; M5 to M8 (PM8-SA only). See “PCB layout diagrams” on page 52 for location of the internal jumpers. The triggers are momentary – i.e., the external contacts need only to close (NO) or open (NC) briefly for the message to be initiated.

Connecting the trigger inputs to equipment with open-collector outputs is also possible, but we recommend that all the equipment involved is located as close as possible to the PM-SA rather than distributed around the building. This is because connecting the PM-SA’s common 0V to items of equipment running on widely-separated AC mains outlets can frequently be problematic. The trigger inputs are diode-clamped, and may be connected to open-collector outputs with Vcc voltages of up to +24V.

Note that the external commands do not directly trigger the individual message stores, but the zone groups A to D (PM4-SA) or A to H (PM8-SA). This is because triggering a stored message is of little use unless one or more destination zones are also defined. The SA models of the PM allow each zone group to have any of the stored messages assigned to it; thus an external trigger causes the message assigned to the particular group to be broadcast to the zone(s) belonging to that group. See “Assigning a chime to a zone group (SA models only)” on page 36 for more details.

When all the connections have been correctly made, tighten the locking clamps on the cable glands to ensure that no strain is placed on the terminals if the external cables are tugged or stretched.

# Configuring the PM

## Zone Groups

Zones may be 'grouped' together to simplify the procedure for paging several zones simultaneously. Up to four groups (A to D) may be defined on PM models PM4, PM8, PM12, PM16 and PM4-SA, and up to eight groups (A to H) on model PM-8SA.

Using groups simplifies operation for the user; when a GROUP button is pressed, the LEDs corresponding to the zones comprising the group illuminate, to give confirmation of which zones are to be addressed. Pressing the TALK (or TALK/SEND) button then activates the PM for all the zones simultaneously.

☐ The SA models of the PM have extra functions allowing specific messages and chimes to also be assigned to zone groups. This gives much greater flexibility in operation, and allows external triggering of pre-recorded messages to pre-determined zones.

Once zone groups have been defined, it is possible to 'lock' the definitions, so that they cannot be inadvertently altered by users. See "Lock Groups" on page 39 for details of this option.

NOTE: - if any zone access is to be restricted by using the PM's Zone Disabling feature, it is recommended that this is done before defining any zone groups (as the NVM reset which forms part of the button disable procedure will cancel any zone groups). See "Disabling Zone buttons" on page 44 for details of how to disable Zone buttons.

### Defining a zone group – groups A to D (all models)

1. Select the zones for the group with the ZONE buttons; the selection will be confirmed by the adjacent LEDs. (An incorrect selection may be cancelled with the CLEAR button.)
2. Press and hold down one of the GROUP buttons until the zone LEDs flash (approx. 5 s).
3. Release the GROUP button.

### Defining a zone group – groups E to H (Model PM-8SA only) ☐

1. Select the zones for the group with the ZONE buttons; the selection will be confirmed by the adjacent LEDs. (An incorrect selection may be cancelled with the CLEAR button.)
2. 'Double-click' and hold down one of the GROUP buttons (approx. 5 s) until the zone LEDs flash.
3. Release the GROUP button.

## Assigning a message to a zone group (SA models only)

On the SA models, any one of the message sound files on the SD memory card may be assigned to a zone group. In this case, when a GROUP is selected, the LED corresponding to the message will illuminate as well as those for the zones comprising the group. When the TALK/SEND button is pressed, the message that has been assigned to the group will automatically be broadcast to the zones comprising the group. A chime file will be assigned at the same time – see the following section “Assigning a chime to a zone group” for details of how to alter this.

To include a message in a group definition, simply press the button for the required message as well as the zone buttons during Step 1 of the zone definition procedures on the previous page. The CLEAR button may be used to cancel an incorrect selection.

## Assigning a chime to a zone group (SA models only)

Pre-recorded messages broadcast by manually selecting the message and its destination zone(s) may be preceded by one of two pre-announcement chimes. See “Chime settings – SA models only” on page 41 for details of how to do this.

Zone groups allows greater flexibility in chime assignment. When a message is assigned to a zone group as described above, the chime file with the same number as the selected message file is assigned as well. Thus if message button 3 is pressed along with the zone buttons defining the zone group, then message file M\_3 .mp3 (or M\_3 .wma) and chime file C\_3 .mp3 (or C\_3 .wma) are assigned to the zone group. However, it is possible for any of the chime sound files on the SD memory card to be assigned to a zone group, whether or not a message is to be assigned to the group. The procedure for defining a group with a different chime is as follows:

1. Select the zones for the group with the ZONE buttons; the selection will be confirmed by the adjacent LEDs.
2. If a pre-recorded message is to be assigned to the group, press the relevant MESSAGE button; its LED will illuminate.
3. Press and hold down a GROUP button until the LEDs flash (approx. 5 s).
4. While the LEDs are flashing, the MESSAGE buttons temporarily act as CHIME buttons. If no further buttons are pressed, the chime that will be assigned to the group will be that having the same number as the selected message – this is the default state.
5. If a different chime is required, press the MESSAGE button corresponding to that chime number.

6. If no chime is required, press the message button with the flashing LED; the LED will go out. The group will now not have a chime assigned.
7. Release the GROUP button.

Note that once a chime is assigned to a group, it is not possible to check which chime it is, as pressing a GROUP button will illuminate the zone and message LEDs, but gives no indication corresponding to the chime.

Note also that if a chime number is assigned for which no chime file exists, the group will operate normally, though there may be a slight delay before a message starts.

## Setup options

The PM has a number of setup options which can be configured during installation. These modify the operation of the unit in various ways, allowing the PM to be optimised for the particular installation. Most of these options are set by moving internal PCB jumpers. See “PCB layout diagrams” on page 52 for a PCB layout diagram identifying the location of all the jumpers. See “Accessing the internal PCB” on page 20 for instructions on how to gain access to the internal PCBs.

**NOTE:** Jumper settings are only checked by the PM’s processor on power-up. In order for jumper changes to be recognised, power to the PM will need to be disconnected and then reconnected.

When removing jumpers it is recommended that the link remains connected to one leg of the header, to prevent losing it.

### Mic Level

Mic volume may be adjusted with the preset control PR2 on the main PCB. See “PCB layout diagrams” on page 52 for the location of this control. It is recommended that, if possible, the operator who will normally make announcements from the PM makes test calls to assess the system volume when adjusting mic level. Note that the microphone will be ‘off’ if PR2 is turned fully anticlockwise.

### Zone Offsets

By default, a zone button on a PM selects paging (and messaging on SA models) to the same-numbered zone. Thus the buttons on a PM4 (or PM4-SA) will normally address Zones 1 to 4, and those on a PM8 (or PM8-SA) Zones 1 to 8. However, there may be situations where a PM is required to address a different subset of available zones to the set starting at Zone 1.

It is possible to “shift” the zones a microphone addresses by any value between 1 and 15 by setting a numerical offset. With an offset applied, the zone a button addresses will be that button’s ‘default’ zone number PLUS the offset value. Example: the four buttons on a PM4 (or PM4-SA) can be made to address Zones 10 to 13 by applying an offset of 9.

Zone offset applies only to the whole set of zone buttons on a PM, not to individual zone buttons. Thus the zone buttons can only ever address a numerically-consecutive subset of the available zones. If an offset is applied which makes one or more buttons address a zone number higher than the system maximum of 16, the numbers “wrap-around” back to 1. Thus applying an offset of 13 to a PM4 would result in its four zone buttons selecting Zones 14, 15, 16 and 1 respectively. It should be evident from this that zone offsets need not normally be set on a PM16, as all available zones are individually selectable in any case. Setting an offset on a PM16 simply has the effect of shifting the numbering of all the zone buttons.

The zone offset applies to both the Digital Paging Interface and the analogue interface. If the analogue interface is being used to connect the PM to the host mixer, the access cable connections (see “2. Zone Selection Control Cable:” on page 31) should be altered to match the zone numbers to be paged, not the button numbers. Thus in the example given above, the zone select cores of the access cable would be connected to Z10 to Z13, and not Z1 to Z4.

## Setting an Offset

Zone offset is set with internal jumpers J11, J12, J13 & J14. See “PCB layout diagrams” on page 52 for a diagram showing the jumper locations. The four jumpers are “binary-weighted”. This means that each jumper corresponds to a different offset value as follows:

Jumper	Value When ‘ON’
J11	8
J12	4
J13	2
J14	1

Example: to set a PM4 (or PM4-SA) to operate on zones 10-13, the offset value needs to be 9. To achieve this, jumpers J11 and J14 should be ON, J12 and J13 should be OFF. (J11=8, J14=1; 8+1=9.)

**NOTE:** Setting a zone offset only alters the button/zone relationship for that microphone. Each microphone in a multi-PM system can operate with its own zone offset.

## Auto-Reset of Zone and Message Selection

By default, the last zone selection and message selection (SA models only) made remain in place after the announcement (or message broadcast) has been made. This enables a supplementary announcement to be made to the same set of zones without selecting them a second time, or for the pre-recorded message to be repeated without re-selection. The retained zone and message selections are indicated by the front panel LEDs.

The PM may be configured to automatically cancel zone selection immediately after an announcement or message broadcast has been made, if this method of operation is preferred by the user. This may suit situations where the combination of selected zones varies from one announcement to the next.

Auto-Reset is enabled by setting jumper J10 to ON. See “PCB layout diagrams” on page 52 for a diagram showing jumper locations. When set, this feature will automatically cancel selected zones and any selected message (SA models only) when the ‘TALK’ (‘TALK/SEND’) or ‘CALL ALL’ buttons are released.

**NOTE:** With auto-reset enabled, if a zone selection (and message selection on the SA model) is made but the TALK (or TALK/SEND) button not pressed, the selection(s) will be cancelled automatically 30 seconds after the last key-press.

## Lock Groups

It is possible to disable Zone group definition (see “Zone Groups” on page 35). This feature may be useful if groups are being defined as part of the installation and it is felt that they will not need to be altered.

Once the groups have been defined, setting jumper J9 to ON will lock these group settings, and it will not be possible to re-define any groups. On the SA models, setting Lock Groups to ON also ensures that any assignment of pre-recorded messages to zone groups cannot be altered.

See “PCB layout diagrams” on page 52 for a diagram showing jumper locations.

**NOTE:** NVM Reset (set with J7 – see “Power-On Non-Volatile Memory (NVM) Reset” on page 42) has priority over Lock Groups. This means that even if Lock Groups is ON when a NVM Reset takes place, the group memories will be cleared.

## Priority settings

**NOTE:** This configuration option is only relevant to systems with more than one PM.

A PM microphone may be set to either NORMAL or HIGH priority; the factory default is NORMAL. Paging (or message initiation) on a network with multiple PMs all set to NORMAL priority will operate on a 'first-come-first-served' basis. This means that when simultaneous paging is attempted from two (or more) PMs, whichever microphone starts its announcement first has command of the system and its announcement will continue uninterrupted. The other PMs will indicate that a page is already taking place by illumination of the BUSY LED.

Setting a PM to HIGH priority gives it precedence over PMs with NORMAL priority. If an announcement is made from a HIGH priority microphone while one is already in progress from a NORMAL priority microphone, that from the HIGH priority microphone will take over. This means that microphones that are set to HIGH priority can make an announcement even if the system is busy, as long as it is not another HIGH priority microphone that is already in use.

On the SA models, this principle applies equally to pre-recorded messages; once a message has been commanded by a HIGH-priority PM, a message (or paging announcement) from a PM set to NORMAL priority will not be broadcast; similarly, a message commanded from a NORMAL priority PM will be interrupted by another initiated on a HIGH priority PM. The BUSY LED will illuminate on the NORMAL priority to indicate that the system is 'busy'.

A PM may be set to HIGH priority by setting J8 to ON. See "PCB layout diagrams" on page 52 for a diagram showing jumper locations.

**NOTE:** Priority settings only apply to microphones using the Digital Paging Interface. If the PMs are being used in conjunction with other (third-party) paging microphones using short-to-ground zone selection, announcement and message collisions can occur even between high priority PMs and the third-party system.

## Chime settings – standard (non-SA) models

The PM microphone includes circuitry which generates four different pre-announcement chimes. The selection of chime is made by setting internal jumpers. It is also possible to disable the chime.

The selected chime sounds whenever the 'TALK' or 'CALL ALL' button is depressed, and is automatically routed to the appropriate zones as well as played through the internal speaker. The chime volume can be set by adjusting the pre-set control PRI inside the microphone. Jumpers J1, J2 & J3 select which of the four available chimes is active, and J5 disables or enables the chime facility. See "PCB layout diagrams" on page 52 for



a diagram showing jumper and level adjustment locations. Chime selection is per-microphone, and setting the chime on a PM will not affect any other PMs on the network.

The table below gives the jumper settings for each chime:

Selection	J3	J2	J1	J5
No Chime	ANY	ANY	ANY	OFF
Chime 1	ANY	OFF	ON	ON
Chime 2	ANY	ON	OFF	ON
Chime 3	ANY	ON	ON	ON
Chime 4	ON	OFF	OFF	ON

Additionally, the internal speaker can be turned off, by setting jumper J6 to OFF.

### Chime settings – SA models only

In SA models of the PM, pre-announcement chimes are derived from sound files stored on the SD memory card. The chime sound files are separate from the message files, and up to eight chime files may be stored on the card. Eight sample MP3 chime files are pre-loaded on the SD card supplied with the PM-SA; four of these (C\_1.mp3 to C\_4.mp3) are recordings of the ‘analogue’ chimes available from the standard (non-SA) PM. Files C\_5.mp3 to C\_8.mp3 are respectively duplicates of these.

### Page Chime

The factory default page (pre-announcement) chime will be the one with the filename C\_1.mp3. If the factory chime file is not suitable, it may be replaced on the card with another sound file using the same name. See “Sound files - types ” on page 12 for more details on file types and recording.

The page chime will sound whenever the TALK/SEND or CALL ALL button is depressed, and is automatically routed to the appropriate zones as well as played through the internal speaker. The chime volume can be set by adjusting the pre-set control PR1 inside the microphone. J1 disables or enables the page chime facility. See “PCB layout diagrams” on page 52 for a diagram showing jumper and level adjustment locations. Page chime assignment is per-microphone, and different PM-SAs on a network may use different chime files, if wished.

## Message chimes

Pre-recorded messages may also be preceded by a chime, and the selection of this is independent of the page chime. Jumper J2 enables or disables the message chime. It is often considered desirable to precede pre-recorded announcements by a different chime to spoken announcements, and thus J3 allows the message chime file to be either C\_1 or C\_2\*.

However, if pre-recorded messages are saved with zone group definitions (necessary if external message triggering is to be used), any of up to eight\*\* chime files may be saved with each. Then, whenever a zone group is selected for message broadcast, the message will always be preceded by a particular chime. As with messages, four chimes are available in the PM4-SA and eight in the PM8-SA. See “Zone Groups” on page 35 for details of how to save messages and chimes as part of zone group definitions.

\* File types may be either MP3 or WMA; unless otherwise indicated filenames in the text omit filename extensions.

\*\* Four chimes max. in PM-SA4

## Power-On Non-Volatile Memory (NVM) Reset

An internal non-volatile memory (NVM) stores user settings such as Group definitions and Zone enabling, so that these are restored automatically in the event of power loss. The PM may be reset to the factory software defaults (group memory empty, all zones enabled), by powering the unit on with jumper J7 set to ON. See “PCB layout diagrams” on page 52 for a diagram showing jumper locations.

Once the reset has been performed, set J7 back to OFF, so that the factory defaults are not recalled if there is a subsequent power interruption.

## Message/chime duration and message cancellation - SA models only

Both messages and chimes may be of any duration: the only limitation is that the SD card has the necessary capacity, bearing in mind the file format in use. However, the default settings of the PM-SA limit the durations to 4 seconds for chimes and 2 minutes for messages.

Once a message has been initiated by pressing the TALK/SEND button, the message, together with any pre-announcement chime will be broadcast in full. This prevents a user from inadvertently cancelling or interrupting the message in some way.

In some applications, it may be desirable for longer chimes and/or messages to be employed: examples are a repeating emergency evacuation message, or a chime that gradually rises in volume. In such a case the default chime/message lengths may be overridden by moving jumper J23 from its factory setting of OFF to ON. With this setting, messages or chimes may be of any length.

When J23 is set to ON, the CLEAR button may be pressed at any time (either during the message itself or its pre-announcement chime) to immediately terminate the broadcast. See “PCB layout diagrams” on page 52 for jumper locations”.

## Disabling Zone buttons

It may occasionally be desired to restrict the zones which a microphone can access. To permit this, zones may be disabled. Note that the disabling of zones is on a per-unit basis, and other microphones in a multiple-PM system will still have free access. On SA models, disabling zone buttons affects both paging and messaging functions.

To disable particular zones on a PM, proceed as follows:

1. Set jumper J7 to ON, and power the unit on (thus performing an NVM reset).
2. Press and hold the CLEAR button.
3. While holding CLEAR down, select the zones to be disabled by pressing the appropriate ZONE buttons.
4. The selected zone lights begin to flash, indicating that the microphone is now in Disable Group Edit mode.
5. Continue to hold the CLEAR button and complete the selection/de-selection process with the ZONE buttons.
6. Release the CLEAR button once the selection is complete. The selected zones will then be written to memory as the Disabled Group.
7. LEDs for the selected zones will remain illuminated to confirm the selection. Press CLEAR again to clear the display.
8. Reset jumper J7 to OFF to prevent a second NVM reset on a subsequent power-up. (It is better to leave the power on for this step.) Once a zone has been disabled, it will be inaccessible to that PM, either via the ZONE and GROUP buttons, or via CALL ALL.

**NOTE:** To cancel zone disabling, perform an NVM reset (see “Power-On Non-Volatile Memory (NVM) Reset” on page 42). This will clear the Disabled Group and re-enable all zones. However, be aware that if an NVM reset is performed for any other reason, any zone disabling required will need to be re-established.

## Terminating the Digital Paging Interface

The Cloud Digital Paging Interface must be correctly terminated at its ends for error-free operation. In systems using a single PM connected to a host mixer via the digital interface (such as the Cloud DCM-1), the terminations should be ON at both the PM and the mixer. In systems with multiple PMs, only the mixer and the PM at the 'end' of the chain should have their terminations set ON; 'intermediate' PMs should have their terminations set to OFF.

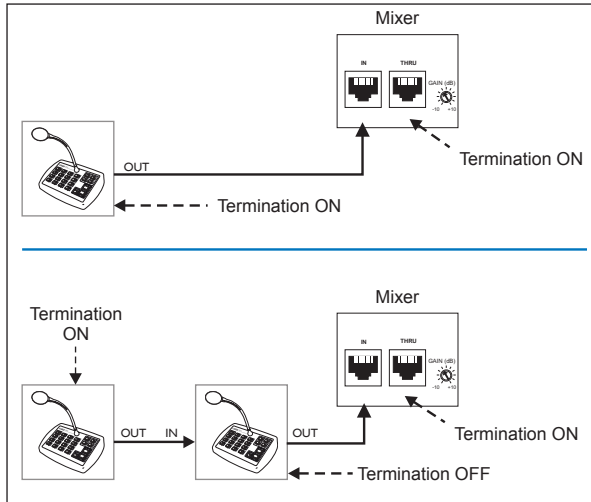

The termination is set in the PM with jumper J4. See “PCB layout diagrams” on page 52 for jumper locations. The factory default setting is for the termination to be set ON. If the PM being configured is ‘mid-chain’, with both its CAN PORT IN and CAN PORT OUT connectors in use, set the termination to OFF by removing the jumper.

## Setting the terminations on the Cloud DCM-I

The Digital Paging Interface is referred to in the DCM-I documentation as the 'CDPM bus'. The termination is set by the DCM-I's internal jumper J2, and is ON when J2 is in place. This is the factory default setting, and is unlikely to require changing. The diagram below shows the jumper's location.

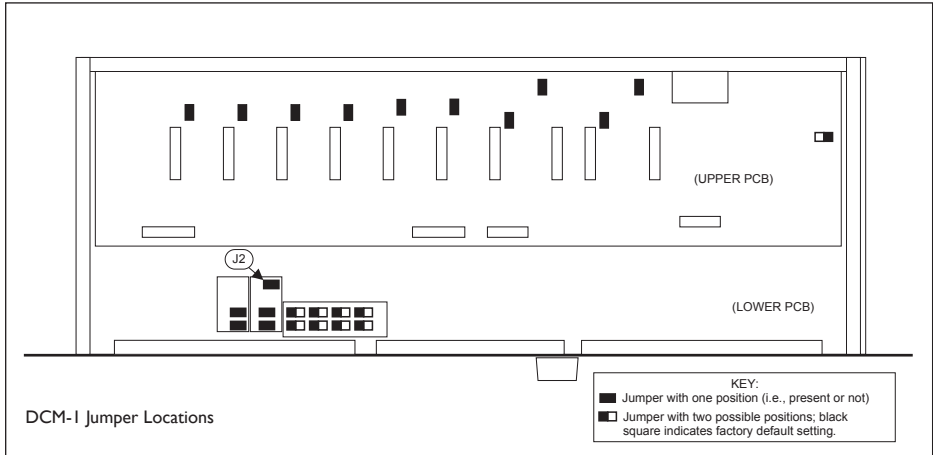

For details of how to set the host mixer's Digital Paging Interface termination correctly in other models, please refer to the documentation supplied with the mixer, or refer to [www.cloud.co.uk](http://www.cloud.co.uk).

## Configuring dual purpose microphone inputs on the Host Mixer

**NOTE:** This section is only applicable to systems using Cloud Integrated Mixers Models 36/50 or 46/50, or Zone Mixers Models CX263 or CX163.

On the above mixers, Mic 1 input needs to be configured for paging use with a Cloud PM by enabling the Mic Access input on the rear panel. Without the Mic Access input enabled, Mic 1 input acts only as a general purpose microphone input and is permanently active.

The table below lists the jumpers within each host mixer that need to be changed.

MIXER	ZONE 1	ZONE 2	ZONE 3	ZONE 4	UTILITY ZONE
36/50	J2	J3			J4
46/50	J23	J22	J21	J20	
CX263	J4	J5	J6		
CX163	J1	J2			J3

Full details of how to enable the Mic Access input can be found in the installation guide supplied with the mixer, or at [www.cloud.co.uk](http://www.cloud.co.uk).

## Systems with multiple paging microphones

Connecting a single Cloud PM microphone to a host mixer is quite straightforward. If more than one microphone is required in a system, various additional factors need to be taken into account. As far as systems with multiple PMs are concerned, most of these factors are already covered elsewhere in the manual. The following information may provide some additional guidance.

**NOTE:** The BUSY LEDs on ALL the microphones in a system illuminate while paging (or messaging on SA models) is taking place, regardless of which microphone is being used.

### System Interconnection

Multiple PMs\* should be interconnected in 'daisy-chain' fashion via the Digital Paging Interface, using CAT-5 cable and RJ45 connectors. In the following description, note that the 'last' PM refers to that connected directly to the host mixer, and the 'end' or 'first' PM refers to that farthest from the mixer in terms of the daisy-chain interconnection (which may not be the same thing as the microphone which is the greatest physical distance from the host mixer).

The CAN PORT OUT of the PM at the 'end' of the network is connected to the CAN PORT IN of the next, whose CAN PORT OUT in turn is connected to the IN of the next, and so on. The 'last' PM in the chain is then connected to the mixer, either by a further CAT-5 connection from its OUT connector to the Digital Paging Interface input on the host mixer, or via the analogue interface using separate audio and access cables. The following examples illustrate some typical situations.

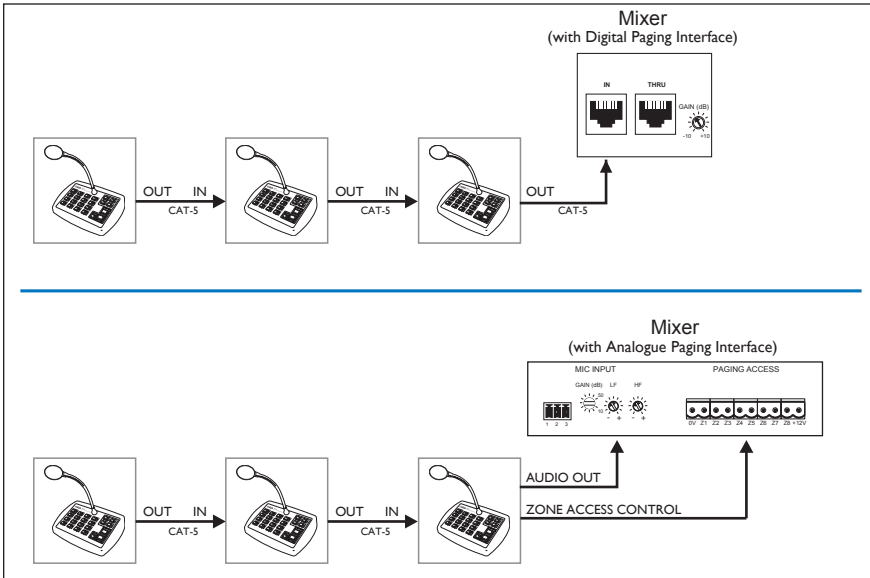

Note that there is no restriction as to the PM model which is the 'last' in the chain – i.e., that which connects directly to the mixer. All PM models support all 16 zones, so in an extreme example, several PM16s could be daisy-chained with a PM4 as the 'last' microphone in the chain. All microphones on the system will have full access to whichever zones are required.

See also “Cables and Connections” on page 29.

\*The Digital Paging Interface also permits PMs to be intermixed with the older Cloud CDPM paging microphones on the same network. Refer to the separate CDPM Installation manual for information (available as a download from the Cloud website).

## Maximum System Capability

Up to 32 PM microphones may be interconnected via the Digital Paging Interface. Different models of PMs, including PM-SAs, may be mixed freely, and each may have a zone offset applied, as required. The total CAT-5 cable run should be less than 1 km.

## Power supply considerations

In a multiple-PM system, only the 'last' microphone in the chain – that which connects directly to the host mixer – may be powered from the host, either via the Digital Paging Interface (if available) or the analogue interface. Alternatively, it may be powered via an external PSU such as the Cloud CPM-PSU. See “Using an External PSU” on page 22 for full details.



All other PMs on the network must be powered individually by external PSUs. DC power is only connected internally at the CAN PORT OUT socket, so the ‘daisy-chain’ data/audio connection cannot be used to pass power between PM units.

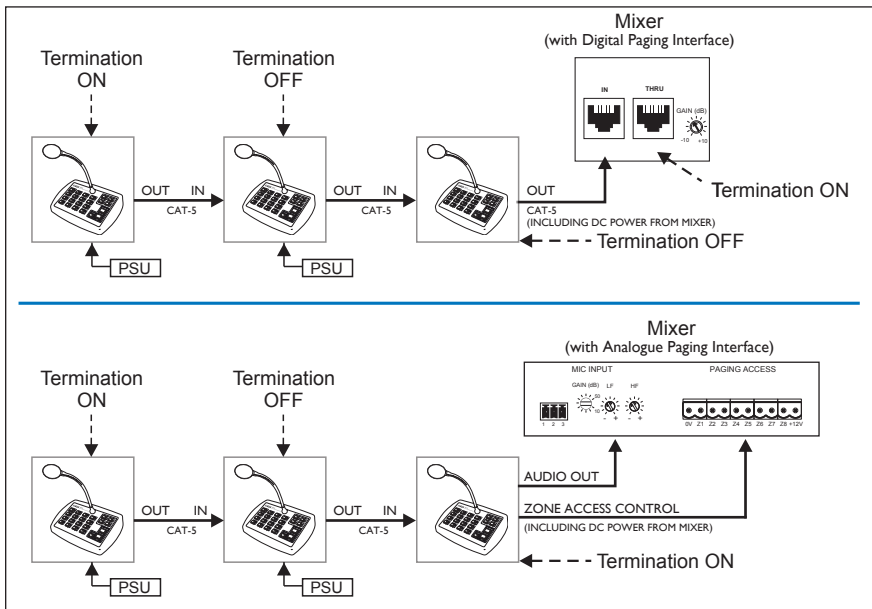

## Terminations

PMs are shipped from the factory with the Digital Paging Interface termination ON. This requires no alteration in single-PM systems, but in multiple-PM systems, only the microphone at the ‘far end’ of the network may have its termination ON; all others must have their terminations set OFF. See “Terminating the Digital Paging Interface” on page 45 for details of how to set the termination.

In all systems, the Digital Paging Interface termination must be set ON in the host mixer. Refer to the mixer documentation for details.

## Using the analogue interface with multiple PMs

The ‘last’ mixer in the chain – that connected to the host mixer – may be connected to the host via the analogue interface instead of the Digital Paging Interface, if the host mixer is not equipped with the digital interface. Connect the PM in the same way as if it was the only PM in the system, using separate audio and control cables. See “Connecting the PM to a mixer via the analogue interface” on page 30 for full details.

Communication between PMs will be via the digital interface, and between the last PM (effectively the whole network) and the host will be via the analogue interface.

Consideration needs to be given to any zone offsets applied to the various PMs on the network. For example, in a 12-zone system with three PM4s configured to page Zones 1 to 4, 5 to 8 and 9 to 12 respectively, analogue port terminals Z1 to Z12 inclusive will need to be wired to the host mixer(s) for correct operation.

## **Priorities**

A potential problem exists in paging systems employing multiple PMs in the form of announcement or message ‘collisions’. A collision will occur if an announcement or message broadcast is attempted from one PM while another is already in progress. As any one microphone will probably be located in earshot of only one zone’s loudspeakers, it is possible for a user to page or broadcast a message to a zone and operators at other microphone locations to be unaware of the usage - should they fail to notice the BUSY LED.

If simultaneous announcements are made, that starting first will take priority and the later one will be unable to proceed. However, it will often be necessary to assign a higher priority to one paging station in the system – typically that in a security office, where it may be the source of emergency announcements. In such a case, an announcement from the high priority microphone will take precedence over any other announcements already in progress. See “Priority settings” on page 40 for details of how to assign priorities to each microphone.

## Using the analogue interface with third-party paging microphones.

It may sometimes be necessary to interface a system consisting of one or more PM microphones to a third-party paging system which uses short-to-ground contacts for paging access. This implies that the host mixer has an analogue paging access port.

It is possible to parallel the third-party system with the Cloud PM analogue interface to the paging access port. It is not recommended to parallel the audio outputs, however; these should use either separate mic inputs if the host mixer permits, or otherwise a simple external 2-into-1 microphone mixer. A suitable arrangement is illustrated here.

Only one PM in a network will require the analogue interface for the whole network to be connected to a short-to-ground paging system. This should be the PM 'nearest' to the host mixer, as with a system comprised of PMs alone.

The PM's analogue interface senses whether the short-to-ground connections are in use by another microphone. If so, it is assumed that the system is busy. If this is so, only high priority microphones on the PM network may make an announcement. This allows the short-to-ground interface to be used in networks which also use other paging equipment such as the earlier Cloud CPM-4 and CPM-8 models.

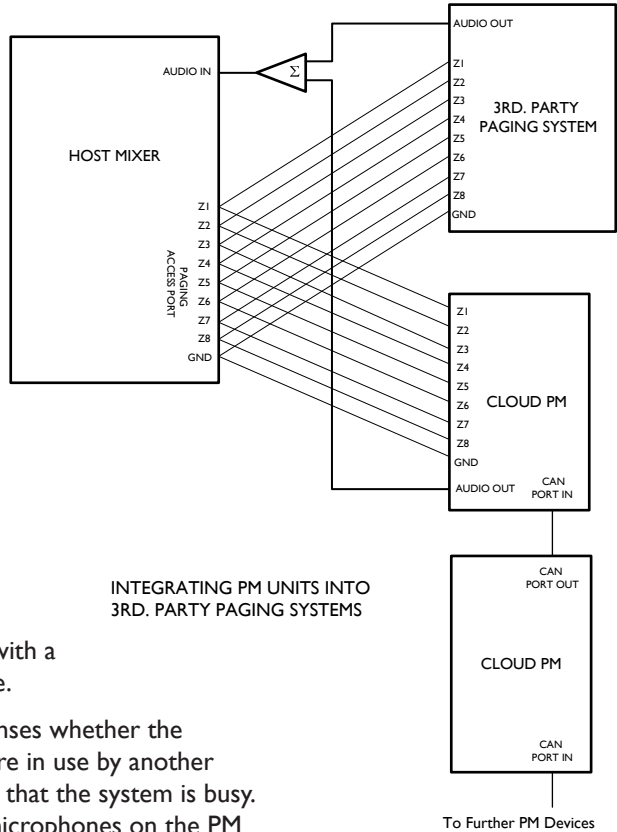

# APPENDIX

## PCB layout diagrams

When removing jumpers we recommend that the link is left connected to one leg of the header to prevent loss of the link.

When making internal adjustments please ensure that you:

- Disconnect power to the unit before accessing the PCB. If the microphone is powered from another unit, this will mean removing the appropriate connection.
- Only reassemble the unit using the original screws.

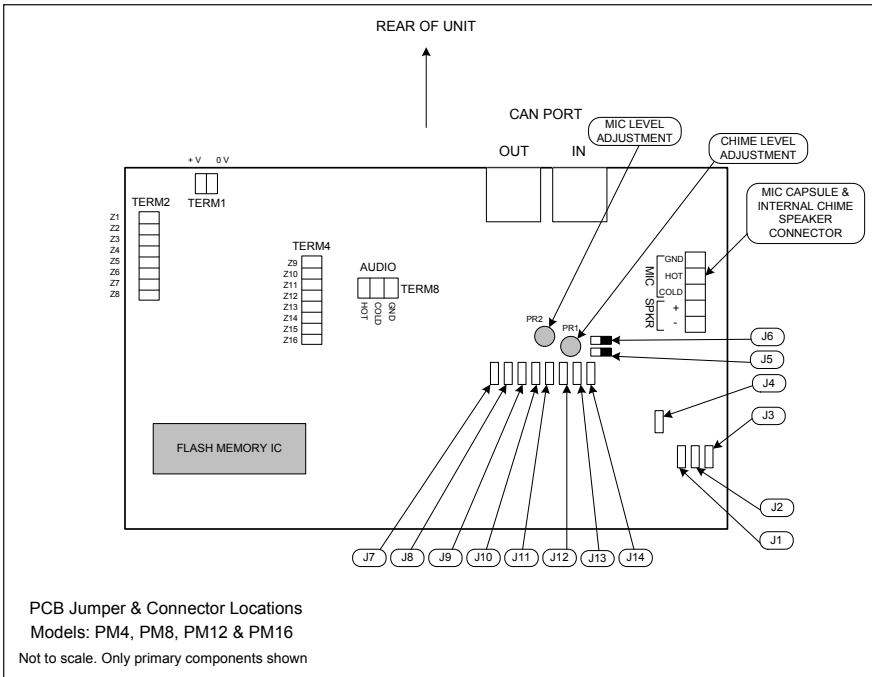

## Jumper and default settings summary – standard (non-SA) models

Jumper	Purpose	Default
J1	Chime Select; +1	ON
J2	Chime Select; +2	OFF
J3	Chime Select; +4	OFF
J4	Digital Paging Interface termination	ON
J5	Chime On/Off	ON
J6	Internal Chime On/Off	ON
J7	NVM Reset	OFF
J8	High Priority	OFF
J9	Lock Groups	OFF
J10	Auto-reset zone selection	ON
J11	Zone Offset; +8	OFF
J12	Zone Offset; +4	OFF
J13	Zone Offset; +2	OFF
J14	Zone Offset; +1	OFF



## Jumper and default settings summary – SA models only

Jumper*	Purpose	Default
J1	Page Chime enable	ON
J2	Message chime enable	ON
J3	Message chime file select	C_1.mp3*
J4	Digital Paging Interface termination	ON
J6	Internal Chime On/Off	ON
J7	NVM Reset	OFF
J8	High Priority	OFF
J9	Lock Groups	OFF
J10	Auto-reset zone selection	ON
J11	Zone Offset; +8	OFF
J12	Zone Offset; +4	OFF
J13	Zone Offset; +2	OFF
J14	Zone Offset; +1	OFF
J20	Message Triggers 1 & 2 N-O/N-C**	N-O
J21	Message Triggers 3 & 4 N-O/N-C**	N-O
J22	Message Triggers 5 to 8 N-O/N-C**	N-O
J23	Maximum message length/enable message cancellation	OFF

\*Jumpers J5 and J15 – J19 are not fitted to the SA models.

\*\*N-O: normally-open; N-C: normally-closed.

## Technical Specifications

		PM4/8/12/16	PM4-SA, PM8-SA
<b>Microphone</b>	Capsule Type	Condenser	
	Polar Pattern	Cardioid	
	Gooseneck length	300 mm (standard); 140 mm (alternative Part No. MII00166)	
<b>Zones</b>	Number of Zones	4, 8, 12 or 16	4 or 8
<b>Chime</b>	Number of Chimes	4; internal speaker	4 or 8 (derived from media card); internal speaker
<b>Interface</b>	Digital	Cloud Digital Paging Interface (RJ45)	
	Analogue	Zone Access Output (Short to Ground), Audio Output	
<b>Messages</b>	Number of messages		4 or 8; internal speaker
	Card format		SD/SDHC MiniSD/SDHC* MicroSD/SDHC*
	Max. card size		2 GB (SD); 32 GB (SDHC)
	File system		FAT16 or FAT32
	File types		MP3 or WMA
<b>Power input</b>	Voltage range	9 - 17 VAC, 12 - 24 VDC	
	Current consumption	72 mA (PM4) 83 mA (PM8) 95 mA (PM12) 107 mA (PM16)	120 mA (PM4-SA, idle mode) 220 mA (PM4-SA, message mode) 150 mA (PM8-SA, idle mode) 250 mA (PM8-SA, message mode)
<b>Dimensions</b>		245 wide x 65 high (less gooseneck mic) x 170 deep (mm)	
<b>Net Weight</b>		1.2 kg	

\* Mini and Micro cards require a suitable adaptor.









[www.cloud.co.uk](http://www.cloud.co.uk)

**cloud**

[www.cloudusa.pro](http://www.cloudusa.pro)

**MADE IN BRITAIN** 