

USER MANUAL

MFR-6100

Multi Format Routing Switcher

MFR-61CPU

MFR-61PS

MFR-9SDI12GA

MFR-9SDO12GA

MFR-9SDI

MFR-9SDO

MFR-GPI





MFR-TALM

3rd Edition - Rev. 2



Precautions

Important Safety Warnings



[Power]

 Caution	Operate unit only at the specified supply voltage.
 Caution	Disconnect the power cord via the power plug only. Do not pull on the cable portion.
 Stop	Do not place or drop heavy or sharp-edged objects on the power cord. A damaged cord can cause fire or electrical shock hazards. Regularly check the power cord for excessive wear or damage to avoid possible fire / electrical hazards.
 Caution	Ensure the power cord is firmly plugged into the AC outlet.

[Grounding]

 Caution	Ensure the unit is properly grounded at all times to prevent electrical shock.
 Hazard	Do not ground the unit to gas lines, units, or fixtures of an explosive or dangerous nature.



[Operation]

 Hazard	Do not operate the unit under hazardous or potentially explosive atmospheric conditions. Doing so could result in fire, explosion, or other hazardous results.
 Hazard	Do not allow liquids, metal pieces, or other foreign materials to enter the unit. Doing so could result in fire, other hazards, or a unit malfunction.
 Caution	If a foreign material does enter the unit, turn the power off and immediately disconnect the power cord. Remove the material and contact an authorized service representative if damage has occurred.

[Transportation]

 Hazard	Handle with care to avoid impact shock during transit, which may cause malfunction. When you need to transport the unit, use the original or suitable alternative packing material.
---	--

[Circuitry Access]

 Do not remove covers, panels, casing, or access the circuitry with power applied to the unit. Turn the power off and disconnect the power cord prior to removal. Internal servicing / adjustment of unit should only be performed by qualified personnel.
 Stop Do not touch any parts / circuitry with a high heat factor. Capacitors can retain enough electric charge to cause mild to serious shock, even after the power has been disconnected. Capacitors associated with the power supply are especially hazardous.
 Hazard Unit should not be operated or stored with cover, panels, and / or casing removed. Operating the unit with circuitry exposed could result in electric shock / fire hazards or a unit malfunction.

[Potential Hazards]

 Caution If abnormal odors or noises are noticed coming from the unit, immediately turn the power off and disconnect the power cord to avoid potentially hazardous conditions. If problems similar to the above occur, contact an authorized service representative before attempting to operate the unit again.
--

[Rack Mount Brackets, Ground Terminal, and Rubber Feet]

 Caution To rack-mount or ground the unit, or to install rubber feet, do not use screws or materials other than those supplied. Doing so may cause damage to the internal circuits or components of the unit. If you remove the rubber feet that are attached to the unit, do not reinsert the screws that secure the rubber feet.

[Consumables]

 Caution Consumable items that are used in the unit must be periodically replaced. For further details on which parts are consumables and when they should be replaced, refer to the specifications at the end of the User Manual. Since the service life of the consumables varies greatly depending on the environment in which they are used, such items should be replaced at an early date. For details on replacing consumable items, contact your dealer.

OpenSSL

This product includes software developed by the OpenSSL Project for use in the OpenSSL Toolkit (<http://www.openssl.org/>)

Freetype

Portions of this software are copyright © 2005 The FreeType Project (www.freetype.org). All rights reserved.

Lighttpd

Copyright © 2004, Jan Kneschke, incremental. All rights reserved.

Redistribution and use in source and binary forms, with or without modification, are permitted provided that the following conditions are met:

- Redistributions of source code must retain the above copyright notice, this list of conditions and the following disclaimer.
- Redistributions in binary form must reproduce the above copyright notice, this list of conditions and the following disclaimer in the documentation and/or other materials provided with the distribution.
- Neither the name of the 'incremental' nor the names of its contributors may be used to endorse or promote products derived from this software without specific prior written permission.

THIS SOFTWARE IS PROVIDED BY THE COPYRIGHT HOLDERS AND CONTRIBUTORS "AS IS" AND ANY EXPRESS OR IMPLIED WARRANTIES, INCLUDING, BUT NOT LIMITED TO, THE IMPLIED WARRANTIES OF MERCHANTABILITY AND FITNESS FOR A PARTICULAR PURPOSE ARE DISCLAIMED. IN NO EVENT SHALL THE COPYRIGHT OWNER OR CONTRIBUTORS BE LIABLE FOR ANY DIRECT, INDIRECT, INCIDENTAL, SPECIAL, EXEMPLARY, OR CONSEQUENTIAL DAMAGES (INCLUDING, BUT NOT LIMITED TO, PROCUREMENT OF SUBSTITUTE GOODS OR SERVICES; LOSS OF USE, DATA, OR PROFITS; OR BUSINESS INTERRUPTION) HOWEVER CAUSED AND ON ANY THEORY OF LIABILITY, WHETHER IN CONTRACT, STRICT LIABILITY, OR TORT (INCLUDING NEGLIGENCE OR OTHERWISE) ARISING IN ANY WAY OUT OF THE USE OF THIS SOFTWARE, EVEN IF ADVISED OF THE POSSIBILITY OF SUCH DAMAGE.

WebHostingHub Glyphs

Copyright (C) 2013 WebHostingHub Glyphs (<http://www.webhostinghub.com/glyphs/>).
This font is licensed under the SIL Open Font License.

Noto Sans CJK JP Medium

Copyright (C) 2014, 2015 Adobe Systems Incorporated (<http://www.adobe.com/>).
This Font Software is licensed under the SIL Open Font License, Version 1.1.

* All other copyrights are property of their respective owners.

Upon Receipt

MFR-6100 units and their accessories are fully inspected and adjusted prior to shipment. Check your received items against the packing lists below. Check to ensure no damage has occurred during shipment. If damage has occurred, or items are missing, inform your supplier immediately.

◆ Main Unit

ITEM	QTY	REMARKS
MFR-6100	1	W/ EIA standard rack mount brackets
AC Cord	1 set	AC cord retainer clip included
Quick Setup Guide	1	

◆ Input / Output Cards

ITEM	QTY	REMARKS
MFR-9SDI12GA	1 - 16*	9 SDI-input card (12G-SDI supported)
MFR-9SDO12GA	1 - 16*	9 SDI-output card (12G-SDI supported)
MFR-9SDI	1 - 16*	9 SDI-input card (6G-SDI supported)
MFR-9SDO	1 - 16*	9 SDI-output card (6G-SDI supported)

* The number of installed cards varies depending on the system configuration. See Sec. 2-1-1. "Matrix Size Chart."

◆ Option (for MFR-6100)

ITEM	QTY	REMARKS
MFR-61CPU	1	Redundant CPU card
MFR-61PS	1 set	Redundant power supply unit (AC cord retainer clip included.)
MFR-8RUA/18RUA/39RUA/40RU MFR-16RU/16RUD/16RUTA MFR-16RUW/32RUW/64RUW	1	Remote Control Unit

◆ Interface Expansion Unit

ITEM	QTY	REMARKS
MFR-GPI	1	
AC Adaptor *	1	With DC lock plug
AC Cord	1	
EIA Rack Mount Brackets	1 set	
LAN Cable (straight)	1	

* Depending on date of production, AC adaptor is supplied without DC lock plug, but with a DC cable retaining clip.

◆ **Tally Manager Unit**

ITEM	QTY	REMARKS
MFR-TALM	1	
AC Adaptor *	1	With DC lock plug
AC Cord	1	
EIA Rack Mount Brackets (optional)	1 set	Single- or Dual-unit type

* Depending on date of production, AC adapter is supplied without DC lock plug, but with a DC cable retaining clip.

Font Conventions

The following conventions are used throughout this manual:

- Shaded text (such as ON) indicates **parameter values** in the menu.
- Text enclosed by a square (such as **ALARM**, **MODE**) indicates **front panel buttons** on the MFR-6100 or Remote Control Units.
- References to the MFR Series Web-based Control Software are indicated by [Web-based Control: XXX page].

Table of Contents

1. Prior to Starting.....	9
1-1. Overview	9
1-2. Features	9
2. Panel Descriptions.....	10
2-1. MFR-6100 Front Panel.....	10
2-1-1. Matrix Size Chart	11
2-2. MFR-6100 Rear Panel	12
2-2-1. Interfaces	13
2-3. SDI Input/Output Cards.....	15
2-3-1. MFR-9SDI12GA.....	15
2-3-2. MFR-9SDI.....	15
2-3-3. MFR-9SDO12GA.....	15
2-3-4. MFR-9SDO	16
2-4. MFR-GPI	16
2-4-1. Front Panel	16
2-4-2. Rear Panel.....	17
2-4-3. Interfaces (MFR-GPI)	18
2-4-4. Card Switches.....	20
2-5. MFR-TALM.....	21
2-5-1. Front Panel	21
2-5-2. Rear Panel.....	22
3. System Configuration Example	23
3-1. Basic Configuration	23
3-2. Main Unit Linking.....	24
3-2-1. Parallel Link System Example	24
3-3. Configuring the System with MFR-TALM.....	25
3-4. Switcher's AUX Crosspoints Switching System.....	28
3-4-1. Switching an AUX Bus Signal.....	28
3-4-2. Synchronous Crosspoints Switching	30
3-5. Redundant CPU Configuration	31
4. Menu Display Operation	32
4-1. STATUS	33
4-1-1. STATUS > INFO	33
4-1-2. STATUS > MFR-LAN.....	34
4-1-3. STATUS > PC-LAN	34
4-1-4. STATUS > SLOT	34
4-1-5. STATUS > POWER	35
4-1-6. STATUS > TEMPERATURE	35
4-1-7. STATUS > FAN	36
4-1-8. STATUS > VERSION	36
4-1-9. STATUS > ALARM	36
4-2. SETTING.....	37
4-2-1. Swapping Active CPU.....	37
4-2-2. Turning ON/OFF an Input/ Output Card	37
4-2-3. Changing Power Supply 2 Installation Status.....	38
4-2-4. Changing Menu Display Settings	39
4-2-5. Power Off for Matrix Card	40
4-2-6. Rebooting CPU1	40
5. Serial / LAN Command Control	41
5-1. Serial Control	41
5-2. LAN Control.....	41
5-3. Control Commands	42

5-3-1. Command Responses (Commands 1-6)	43
5-3-2. Receiving Responses (Commands 1-6)	45
5-3-3. Channel Name Request Commands (7)	48
5-3-4. CPU Status Request Command (8)	52
5-3-5. Destination Lock Status Request Command (9)	53
5-3-6. Channel Name Import Commands (10)	54
5-3-7. Video Format Commands (11)	54
5-3-8. CPU Change-over Commands (12)	56
6. Troubleshooting	57
7. Specifications and Dimensions	58
7-1. Unit Specifications	58
7-1-1. MFR-6100	58
7-1-2. MFR-GPI	59
7-1-3. MFR-TALM	60
7-2. External Dimensions	61
7-2-1. MFR-6100	61
7-2-2. MFR-GPI	61
7-2-3. MFR-TALM	62

1. Prior to Starting

1-1. Overview

The MFR-6100 is a multi-format routing switcher that supports 12G-SDI, 6G-SDI, 3G-SDI, HD-SDI and SD-SDI signals. Inside the 13U case a matrix of up to 144 inputs/ 144 outputs can be configured. It supports various functions such as the capability of linking multiple units, tally connections with peripheral devices, and automatic source name tracking, to allow the units to be the core product in A/V systems.

1-2. Features

- Support for **12G-SDI, 6G-SDI, 3G-SDI, HD-SDI** and **SD-SDI** signals with automatic signal recognition that enables operation without concern for the type of signal.
- One routing switcher can be virtually partitioned to build any theoretical hierarchy, which creates possibilities for use in various operating forms.
- Various crosspoint control functions such as **Salvo, Take, Link, Level** operation, and **Chop**
- **Tally linking** with FOR-A's video switchers (HANABI Series) and multi viewers. Source name displayed on video switchers and multi viewers can be simultaneously changed according to crosspoint switching on MFR routers by TSL or Harris protocol, which also enables linkage to other companies' products.
- Built-in webserver for **remote control** through a web browser
- **SNMP support** enabling SNMP monitoring system configuration
- **Status monitoring** for power supply, fan, CPU, SDI input/output, etc.
- **CPU card redundancy** allowing monitoring of primary CPU card operation via the secondary card. Real time and smooth switching over to secondary card in case of malfunctions, as well as stable remote control operation supported by **network redundancy**
- **Power unit redundancy** for stable power supply against power unit failure or power supply troubles
- Main unit front display of settings and alarms enabling the main unit to take over operation in the event a remote environment goes down.
- Matrix partition and level setting capabilities support a flexible control environment (maximum of 128 units total including main unit)
- Remote control panel connectivity for configuring a huge control panel
- Interface expansion unit (**MFR-GPI**) for additional 128 (32 x 4) GPI/O and 4 serial ports (9-pin D-sub, male)
- **MFR-TALM** Tally Manager Unit is designed specifically to manage tally and signal name data in the MFR system and exchange of this data with external devices such as video switchers, multiviewers, etc. The unit performs the task of tally data computation, ordinarily undertaken by the MFR main unit, to accelerate the task.
- MFR-9SDI12GA for monitoring input signal CRC error.

2. Panel Descriptions

2-1. MFR-6100 Front Panel

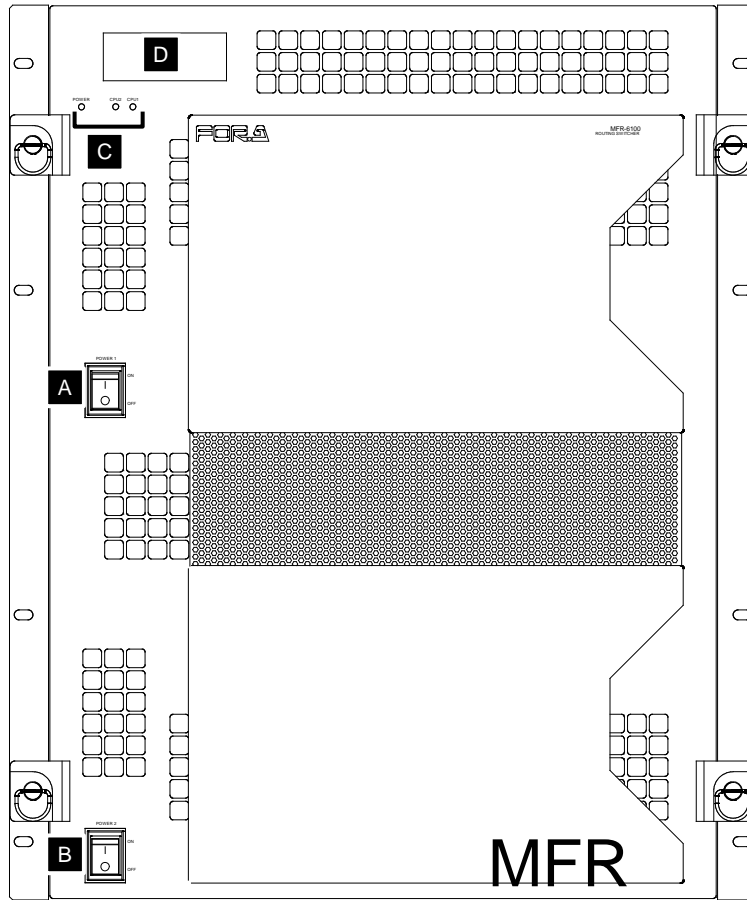

No.	Name	Description		
A	POWER1	Switch used to turn unit power ON / OFF.		
B	POWER2	Switch used to power ON / OFF the optional power supply.		
C	Status Indicators	POWER	Lit green	Power is supplied to the unit.
			Unlit	No power is supplied to the unit. Or power supply unit is not installed.
			Lit red	A failure has occurred. Turn off the power supply unit immediately and consult your reseller.
		CPU1	Lit green	CPU1 card (standard equipment/ Primary CPU) is active.
			Unlit	CPU1 card (standard equipment/ Primary CPU) is inactive.
			CPU2	Lit green
Unlit	CPU2 card (optional equipment/ Secondary CPU) is inactive.			
D	Menu Display	Displays menu. See Sec. 4. "Menu Display Operation" for details.		

2-1-1. Matrix Size Chart

Matrix size varies depending on the number of installed MFR-9SDI12GA, MFR-9SDI, MFR-9SDO12GA and MFR-9SDO cards as shown below. (144 x 144 to 9 x 9)

		Number of cards: MFR-9SDO12GA or MFR-9SDO															
		16	15	14	13	12	11	10	9	8	7	6	5	4	3	2	1
Number of cards: MFR-9SDI12GA or MFR-9SDI	16	144	144	144	144	144	144	144	144	144	144	144	144	144	144	144	144
		x	x	x	x	x	x	x	x	x	x	x	x	x	x	x	x
	15	144	135	126	117	108	99	90	81	72	63	54	45	36	27	18	9
		x	x	x	x	x	x	x	x	x	x	x	x	x	x	x	x
	14	135	135	135	135	135	135	135	135	135	135	135	135	135	135	135	135
		x	x	x	x	x	x	x	x	x	x	x	x	x	x	x	x
	13	144	135	126	117	108	99	90	81	72	63	54	45	36	27	18	9
		x	x	x	x	x	x	x	x	x	x	x	x	x	x	x	x
	12	126	126	126	126	126	126	126	126	126	126	126	126	126	126	126	126
		x	x	x	x	x	x	x	x	x	x	x	x	x	x	x	x
	11	144	135	126	117	108	99	90	81	72	63	54	45	36	27	18	9
		x	x	x	x	x	x	x	x	x	x	x	x	x	x	x	x
	10	108	108	108	108	108	108	108	108	108	108	108	108	108	108	108	108
		x	x	x	x	x	x	x	x	x	x	x	x	x	x	x	x
	9	144	135	126	117	108	99	90	81	72	63	54	45	36	27	18	9
		x	x	x	x	x	x	x	x	x	x	x	x	x	x	x	x
8	99	99	99	99	99	99	99	99	99	99	99	99	99	99	99	99	
	x	x	x	x	x	x	x	x	x	x	x	x	x	x	x	x	
7	144	135	126	117	108	99	90	81	72	63	54	45	36	27	18	9	
	x	x	x	x	x	x	x	x	x	x	x	x	x	x	x	x	
6	90	90	90	90	90	90	90	90	90	90	90	90	90	90	90	90	
	x	x	x	x	x	x	x	x	x	x	x	x	x	x	x	x	
5	144	135	126	117	108	99	90	81	72	63	54	45	36	27	18	9	
	x	x	x	x	x	x	x	x	x	x	x	x	x	x	x	x	
4	81	81	81	81	81	81	81	81	81	81	81	81	81	81	81	81	
	x	x	x	x	x	x	x	x	x	x	x	x	x	x	x	x	
3	144	135	126	117	108	99	90	81	72	63	54	45	36	27	18	9	
	x	x	x	x	x	x	x	x	x	x	x	x	x	x	x	x	
2	72	72	72	72	72	72	72	72	72	72	72	72	72	72	72	72	
	x	x	x	x	x	x	x	x	x	x	x	x	x	x	x	x	
1	144	135	126	117	108	99	90	81	72	63	54	45	36	27	18	9	
	x	x	x	x	x	x	x	x	x	x	x	x	x	x	x	x	

2-2. MFR-6100 Rear Panel

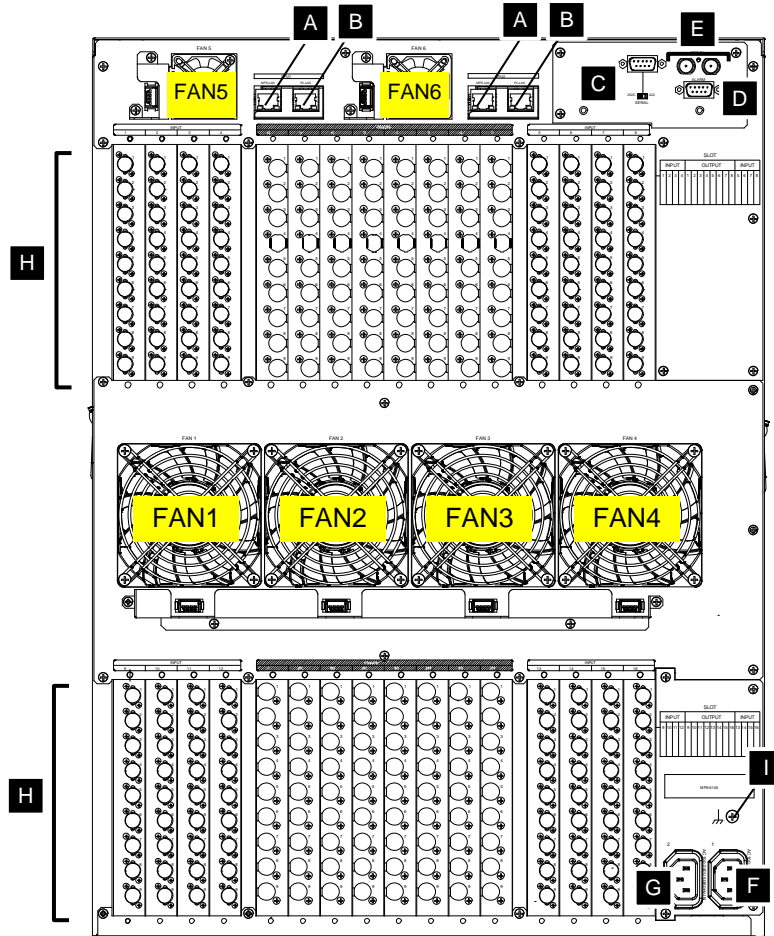

*The above figure shows an MFR-6100 with MFR-9SDI12GA and MFR-9SDO12GA cards installed.

No.	Name	Description
A	MFR-LAN (CPU1 / CPU2)	Ethernet ports for connection to MFR Remote Control Units and MFR-GPI (10/100BASE-TX, RJ-45)
B	PC-LAN (CPU1 / CPU2)	Ethernet ports for connection to PC or other external unit (10/100/1000BASE-T, RJ-45)
C	SERIAL	Used for control via a serial interface. RS-232C or RS-422 selectable. ▶ See Sec. 2-2-1. "Interfaces."
D	ALARM	Used for alarm output ▶ See Sec. 2-2-1. "Interfaces."
E	REF IN1, 2	Used to input reference signals (BB or Tri-level sync signal) (with loop-through. Terminate with 75-ohm terminator, if unused.)
F	AC IN1	Used to connect Power Supply Unit 1 (standard equipment) to an AC power source
G	AC IN2	Used to connect Power Supply Unit 2 (optional) to an AC power source
H	SLOTS for Input/ Output Cards	Used to install SDI input/output cards. ▶ See Sec. 2-3. "SDI Input/Output Cards."
I	Ground Terminal	Used to ground the unit to protect operators against static electricity and/ or electrical shock.

IMPORTANT

All 4 MFR-LAN and PC-LAN connectors (2 each) must be connected to their respective devices to enable CPU redundancy. The LAN connections for MFR Series devices must be separated from the network segment of other devices. Do not use the spanning tree or other functions that inhibit or restrict communication in MFR-LAN.

2-2-1. Interfaces

◆ SERIAL Connector (9-pin D-sub, male)

Select RS-232C or RS-422 using the slide switch at the bottom of the connector.

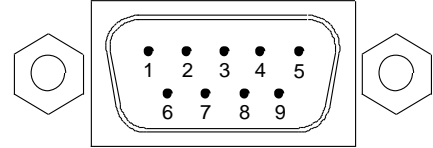

RS-232C Connector Pin Assignments

Pin No.	Signal Name	Description
1	NC	Not used
2	RxD	Received Data
3	TxD	Transmitted Data
4	DTR	Data Terminal Ready
5	SG	Signal Ground
6	DSR	Data Set Ready
7	RTS	Request to Send
8	CTS	Clear to Send
9	NC	Not used

The maximum cable length is 10 m.

DTR/DSR and RTS/CTS are internally connected respectively.

RS-422 Connector Pin Assignments (Factory default settings)

Pin No.	Signal Name	Description
1	FG	Frame ground
2	T-	Transmit data (-)
3	R+	Receive data (+)
4	SG	Signal Ground
5	NC	Not used
6	SG	Signal Ground
7	T+	Transmit data (+)
8	R-	Receive data (-)
9	FG	Frame Ground

The maximum cable length is 100 m.

◆ **ALARM Connector (9-pin D-sub, female)**

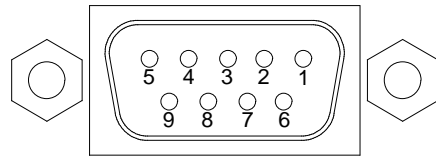

Alarm 1 Out:

Normal operation:	Pins 1 and 6 are open.
Malfunction or power-off:	Pins 1 and 6 are closed.

Alarm 2 Out:

Normal operation:	Pins 2 and 7 are open.
Malfunction or power-off:	Pins 2 and 7 are closed.

ALARM Connector Pin Assignments

Pin No.	Signal Name	Description
1	ALARM 1 OUT	Alarm 1 output (Default setting: Fan)
2	ALARM 2 OUT	Alarm 2 output (Default setting: Power)
3	NC	Not used
4	NC	Not used
5	NC	Not used
6	ALARM 1 COMMON	Alarm 1 output, common
7	ALARM 2 COMMON	Alarm 2 output, common
8	GND	Signal Ground
9	GND	Signal Ground

The following items can be set for ALARM1OUT and ALARM2 OUT.

Alarms can be assigned in [MFR-6100 > MU Settings > Alarm Connector] menu in Web-based Control.

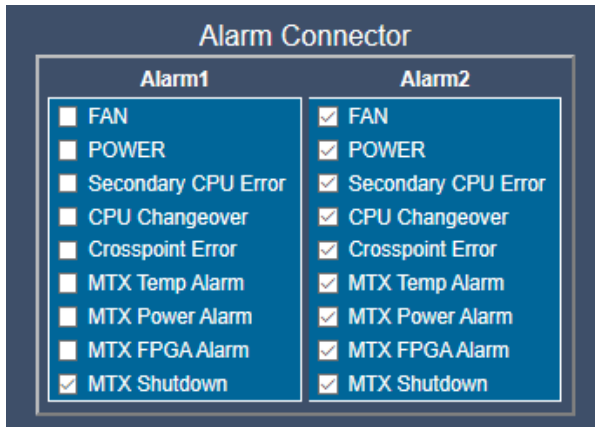

Select items for Alarm1 or Alarm2 outputs and click **Send**.

When two or more items are checked, an alarm outputs if a failure occurs in any one of the items.

FAN	Fan alarms are output if any failure occurs in any cooling fans.
POWER	Power alarms are output if a failure occurs in any of the power supply units. * A warning message appears if POWER is not checked in either Alarm1 or Alarm2.
Secondary CPU Error	An alarm is output if any failure occurs in the secondary CPU.
CPU Changeover	An alarm is output if the secondary CPU is activated to change over operation.
Crosspoint Error	An alarm is output if any crosspoint error occurs.
MTX Temp Alarm	An alarm is output if temperature error occurs in the matrix card.

MTX Power Alarm	An alarm is output if power failure occurs in the matrix card.
MTX FPGA Alarm	An alarm is output if any failure occurs in the FPGA on the matrix card.
MTX Shutdown	An alarm is output if the matrix card power is turned off.

2-3. SDI Input/Output Cards

2-3-1. MFR-9SDI12GA

The MFR-9SDI12GA is an SDI input card. Nine 12G/6G/3G/HD/SD-SDI signals can be input. Set up input signals in the Web-based Control Software as shown below.

◆ **Source Name**

Open the [Web-based Control: **ROUTER SYSTEM SETTINGS - Source Name** page].

This page allows you to change source names displayed on Remote Controllers or other devices.

◆ **Source Assignment**

Open the [Web-based Control: **ROUTER SYSTEM SETTINGS - Source Assignment** page].

This page allows you to assign physical inputs to logical input channels.

2-3-2. MFR-9SDI

The MFR-9SDI is an SDI input card. Nine 6G/3G/HD/SD-SDI signals can be input. Set up input signals in the Web-based Control Software as shown below.

◆ **Source Name**

Open the [Web-based Control: **ROUTER SYSTEM SETTINGS - Source Name** page].

This page allows you to change source names displayed on Remote Controllers or other devices.

◆ **Source Assignment**

Open the [Web-based Control: **ROUTER SYSTEM SETTINGS - Source Assignment** page].

This page allows you to assign physical inputs to logical input channels.

2-3-3. MFR-9SDO12GA

The MFR-9SDO12GA is an SDI output card. Nine 12G/6G/3G/HD/SD-SDI signals can be output.

Set up output signals in the Web-based Control Software as shown below.

◆ **Destination Name**

Open the [Web-based Control: **ROUTER SYSTEM SETTINGS - Destination Name** page].

This page allows you to change destination names displayed on Remote Controllers or other devices.

◆ **Destination Assignment**

Open the [Web-based Control: **ROUTER SYSTEM SETTINGS - Destination Assignment** page].

This page allows you to assign physical outputs to logical output channels.

2-3-4. MFR-9SDO

The MFR-9SDO is an SDI output card. Nine 6G/3G/HD/SD-SDI signals can be output. Set up output signals in the Web-based Control Software as shown below.

◆ Destination Name

Open the [Web-based Control: **ROUTER SYSTEM SETTINGS - Destination Name** page]. This page allows you to change destination names displayed on Remote Controllers or other devices.

◆ Destination Assignment

Open the [Web-based Control: **ROUTER SYSTEM SETTINGS - Destination Assignment** page].

This page allows you to assign physical outputs to logical output channels.

2-4. MFR-GPI

2-4-1. Front Panel

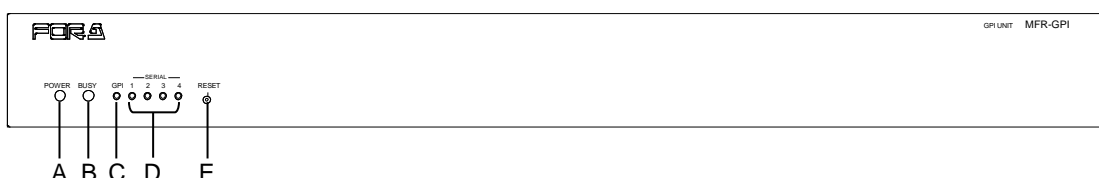

No.	Item	Description
A	POWER	Displays the power status. ▶ See the table below for details on indications.
B	BUSY	Displays the flash memory writing status of backup settings. ▶ See the table below for details on indications.
C	GPI	When the GPI function is assigned using Web-based Control, the LED lights green. The LED remains unlit when there is no assignment.
D	SERIAL1 - 4	When a serial port is assigned using Web-based Control, the LED lights green. The LED remains unlit when there is no assignment.
E	RESET	Used to re-initialize the GPI unit.

◆ Color indications on the MFR-GPI front panel

LED	LED Color	Green	Red	Orange
POWER		Normal	Power alarm	
BUSY		Normal processing		Writing to flash memory

* POWER LED lights red if the unit is turned on but is unconnected to a network.

IMPORTANT

After finishing settings, do **not power OFF** the unit while BUSY LED is **lit orange**, since the system is writing to Flash memory. (Approx. 2 minutes max.)

2-4-2. Rear Panel

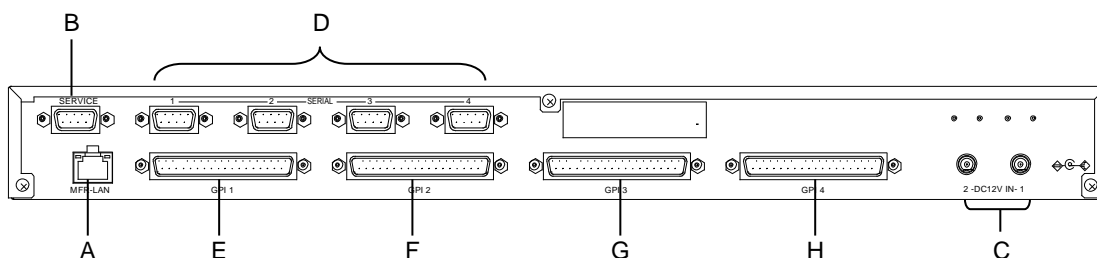

No.	Item	Description
A	MFR-LAN *1	Used to connect the MFR main unit Ethernet port (10/100 BASE-TX)
B	SERVICE	Used for maintenance only. Do not use.
C	DC12V IN 1, 2	Used to supply 12V DC power.
D	SERIAL1 - 4	Used for serial interface control. The default setting is RS-232C. RS-422 is also selectable using switches on the internal card. ▶ See Sec. 2-4-4. "Card Switches." Pin assignments are the same as those on the MFR main unit. ▶ See Sec. 2-2-1. "Interfaces."
E	GPI 1 (Port no: 1)	Used for GPI input / output connections. (32 total assignable inputs and outputs)
F	GPI 2 (Port no: 2)	Used for GPI input / output connections. (32 total assignable inputs and outputs)
G	GPI 3 (Port no: 3)	Used for GPI input / output connections. (32 total assignable inputs and outputs)
H	GPI 4 (Port no: 4)	Used for GPI input / output connections. (32 total assignable inputs and outputs)

*1 The MFR-LAN connector may be labeled 10/100BASE-T on the previous model.

2-4-3. Interfaces (MFR-GPI)

◆ GPI IN / TALLY OUT Connector (37-pin D-sub, female)

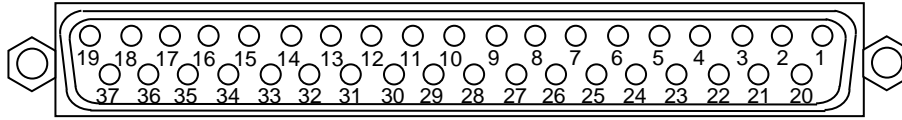

Pin No.	Signal	Pin No.	Signal
1	GPI_IN / TALLY_OUT 01 #	20	GPI_IN / TALLY_OUT 20 #
2	GPI_IN / TALLY_OUT 02 #	21	GPI_IN / TALLY_OUT 21 #
3	GPI_IN / TALLY_OUT 03 #	22	GPI_IN / TALLY_OUT 22 #
4	GPI_IN / TALLY_OUT 04 #	23	GPI_IN / TALLY_OUT 23 #
5	GPI_IN / TALLY_OUT 05 #	24	GPI_IN / TALLY_OUT 24 #
6	GPI_IN / TALLY_OUT 06 #	25	GPI_IN / TALLY_OUT 25 #
7	GPI_IN / TALLY_OUT 07 #	26	GPI_IN / TALLY_OUT 26 #
8	GPI_IN / TALLY_OUT 08 #	27	GPI_IN / TALLY_OUT 27 #
9	GPI_IN / TALLY_OUT 09 #	28	GPI_IN / TALLY_OUT 28 #
10	GPI_IN / TALLY_OUT 10 #	29	GPI_IN / TALLY_OUT 29 #
11	GPI_IN / TALLY_OUT 11 #	30	GPI_IN / TALLY_OUT 30 #
12	GPI_IN / TALLY_OUT 12 #	31	GPI_IN / TALLY_OUT 31 #
13	GPI_IN / TALLY_OUT 13 #	32	GPI_IN / TALLY_OUT 32 #
14	GPI_IN / TALLY_OUT 14 #	33	Frame ground
15	GPI_IN / TALLY_OUT 15 #	34	Frame ground
16	GPI_IN / TALLY_OUT 16 #	35	Frame ground
17	GPI_IN / TALLY_OUT 17 #	36	+4.8V output
18	GPI_IN / TALLY_OUT 18 #	37	+4.8V output
19	GPI_IN / TALLY_OUT 19 #		

- * The symbol "#" at the end of signals represents the port number (1, 2, 3 or 4).
- * The maximum total output current for all +4.8 V outputs is 1.5 A.
- * The GPI input pulse width should be 54 ms or more.

◆ GPI IN Circuits

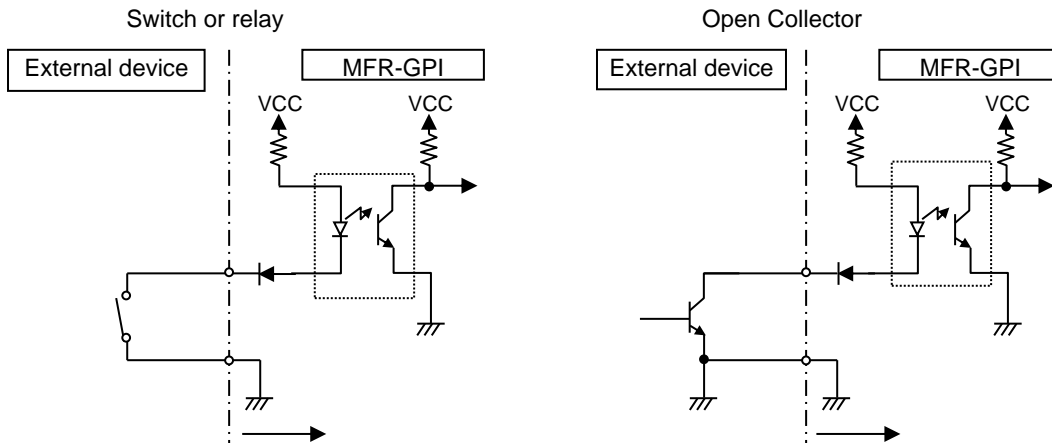

GPI OUT / TALLY OUT Circuit

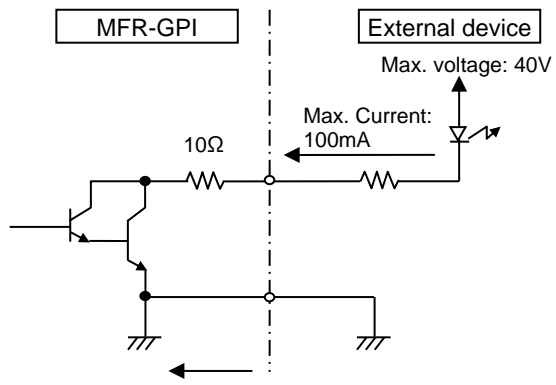

* Approx. 0.9V when turned-on

2-4-4. Card Switches

 CAUTION	<p>Do not access internal cards or make connections with the unit powered ON. Always power OFF all connected units / disconnect AC cords prior to accessing the interior.</p> <p>Further note that adjustments and maintenance should only be performed by qualified technical personnel familiar with FOR-A equipment.</p>
---	---

Remove the two screws on both sides of the MFR-GPI to access the internal card as shown below. The figure below shows the factory default switch settings.

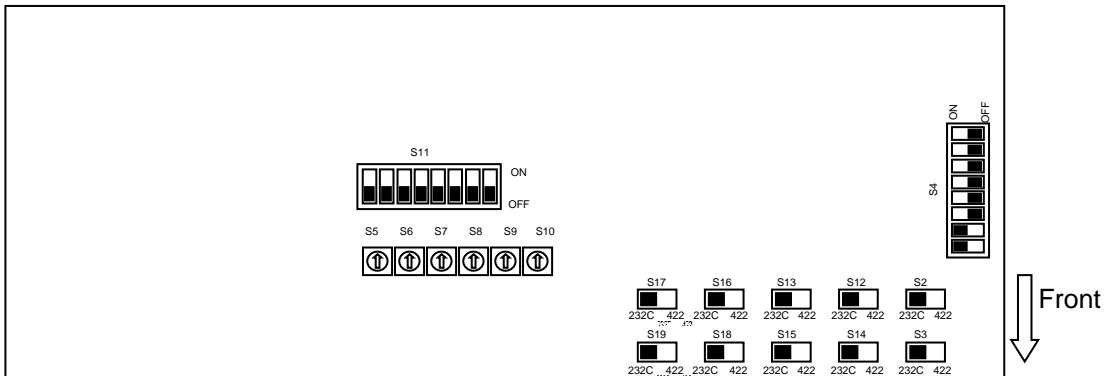

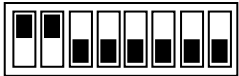
Switch	Function / Settings		
S2,S3	Used for maintenance. Do not use.		
S4	Used for maintenance. Do not use. (Factory default settings are as shown at right. The black boxes (■) represent switches.)		
S5,S6,S7, S8,S9,S10	Used for maintenance. Do not use.		
S11	Used for maintenance. Do not use.		
S12,S14	Used to select RS-232C/RS-422 for SERIAL 1. The default setting is RS-232C (both switches to the left). To change to RS-422, set both switches to the right.	Switch Settings	RS-232C (Factory default setting) RS-422
S13,S15	Used to select RS-232C/RS-422 for SERIAL 2. The default setting is RS-232C (both switches to the left). To change to RS-422, set both switches to the right.		
S16,S18	Used to select RS-232C/RS-422 for SERIAL 3. The default setting is RS-232C (both switches to the left). To change to RS-422, set both switches to the right.		
S17,S19	Used to select RS-232C/RS-422 for SERIAL 4. The default setting is RS-232C (both switches to the left). To change to RS-422, set both switches to the right.		

2-5. MFR-TALM

2-5-1. Front Panel

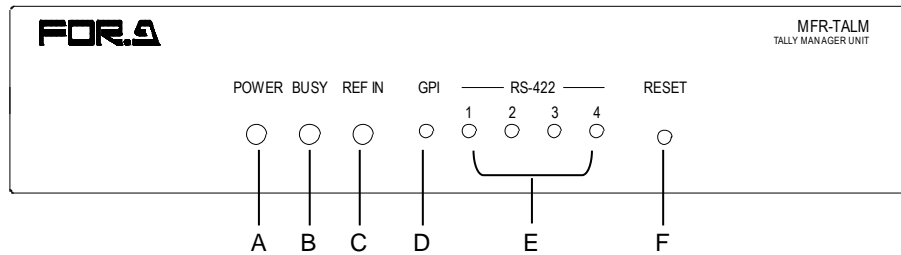

No.	ITEM	Description
A	POWER	Displays power status. ▶ See the table below for details on indications.
B	BUSY	Displays the flash memory writing status of backup settings. ▶ See the table below for details on indications.
C	REF IN	Lights green when an external reference signal is present.
D	GPI	Lights green when a GPI function is assigned. Turns off when no GPI function is assigned.
E	RS-422 1-4	Lights green when a port function is assigned. Turns off when no port function is assigned.
F	RESET	Resets MFR-TALM.

◆ Color indications on the MFR-TALM front panel

LED Color	Green	Red	Orange
LED			
POWER	Normal	Power alarm	
BUSY	Normal processing		Writing to flash memory

IMPORTANT

Do not power off the unit while BUSY LED is lit orange (writing to the flash memory, about 2 minutes remain).

2-5-2. Rear Panel

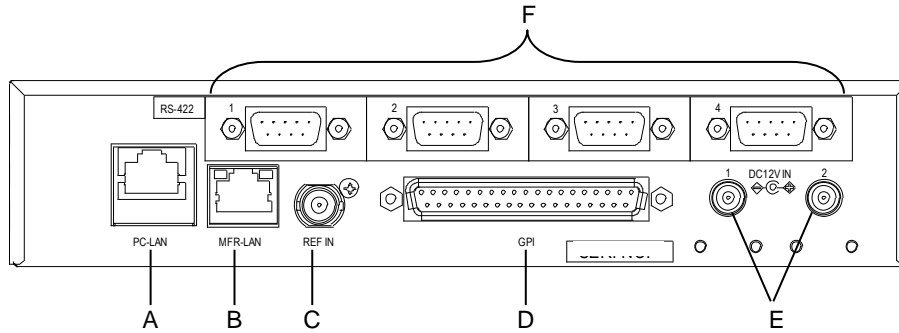

No.	ITEM	Description
A	PC-LAN	Ethernet port for connection to PC or other external unit (10/100BASE-TX, RJ-45)
B	MFR-LAN	Ethernet port for connection to MFR main unit (10/100/1000BASE-T, RJ-45)
C	REF IN	Used to input a reference signal (BB or Tri-level sync signal) (with loop-through. Terminate with 75-ohm terminator, if unused.)
D	GPI	Used to input/output GPI signals for external control. (32 total assignable inputs and outputs) Pin assignments are the same as those of the MFR-GPI connectors. ▶ See Sec. 2-4-3. "Interfaces (MFR-GPI)."
E	DC12V IN 1,2	Used to supply 12 V DC power.
F	RS-422 1-4	Used for RS-422 interface control. Pin assignments are the same as those of the MFR main unit. ▶ See Sec. 2-2-1. "Interfaces."

3. System Configuration Example

3-1. Basic Configuration

The block diagram below shows an example of the basic MFR routing system that consists of an MFR-6100, Remote Unit and the Web-based Control accessed from a computer.

Make sure to connect both MFR-LANs (CPU1) and (CPU2) to a LAN respectively for CPU redundancy. Their LAN connections must be separated from the PC-LAN network segment and other devices. (Default IP addresses (Net mask: 255.255.255.0) are used in the configuration example below.)

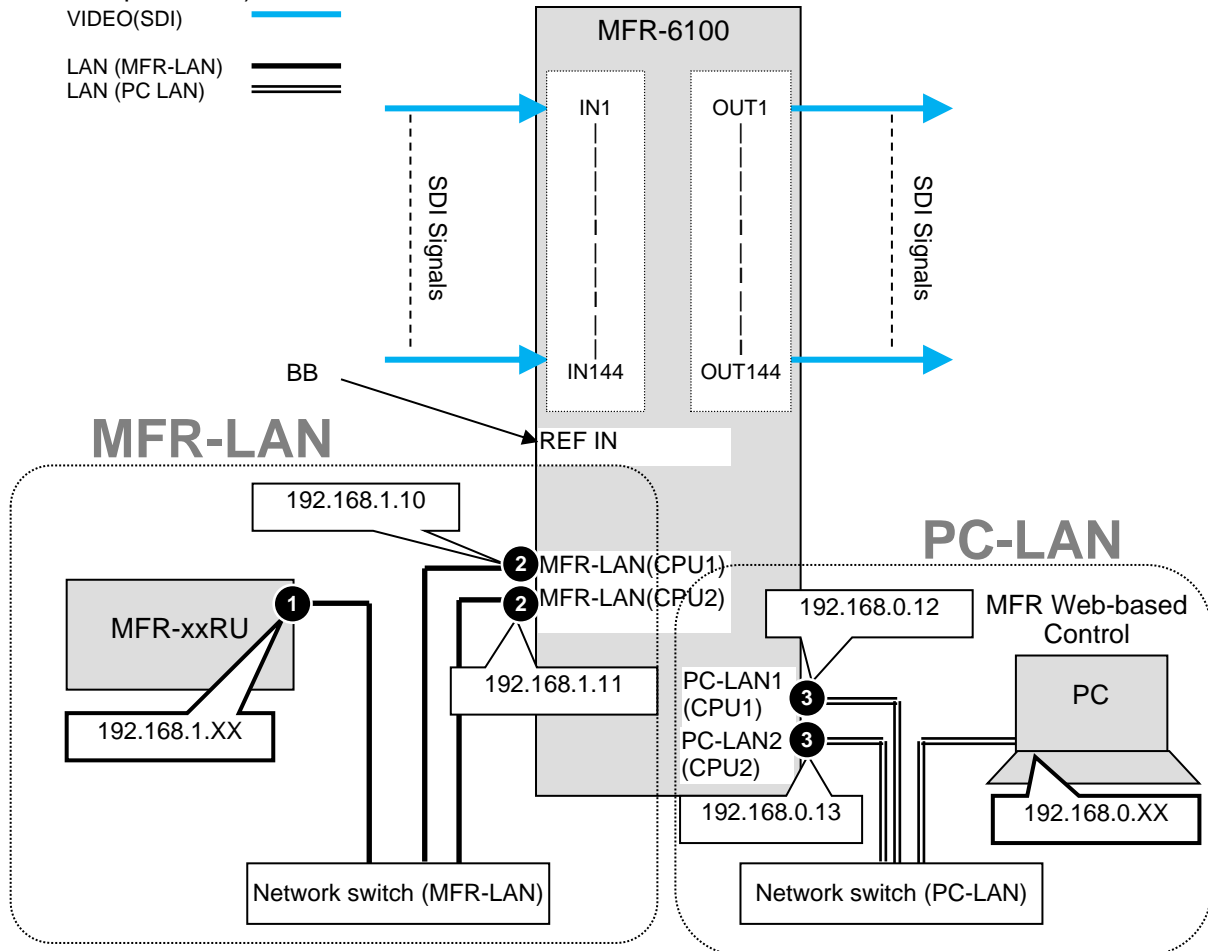

LAN Port Settings

Port	RU Front Panel "Sec. in MFR-RU Series User Manual"	Web-based Control
①	MFR-39RUA: "Setting Mode Menu (MFR-39RUA)" MFR-39RU: "Setup Menu (MFR-39RU)" MFR-18RU/18RUA: "Setup Menu (MFR-18RU/18RUA)" MFR-16RUTA: "Setup Menu (MFR-16RUTA)" MFR-8RUA: "Setup Menu (MFR-8RUA)" Other RUs: "Setup Menu (MFR-16/40RU/16RUD/ MFR-16/32/64RUW)"	[RU Settings page]
②	---	[MU Settings page]
③	MFR-39RUA: "Setting Mode Menu (MFR-39RUA)" (Display only) MFR-39RU: "Setup Menu (MFR-39RU)" (Display only) MFR-18RU/18RUA: "Setup Menu (MFR-18RU/18RUA)" (Display only) MFR-16RUTA: "Setup Menu (MFR-16RUTA)" (Display only) MFR-8RUA: "Setup Menu (MFR-8RUA)" (Display only) Other RUs: "Setup Menu (MFR-16RU/40RU/16RUD/ MFR-16/32/64RUW)" (Display only)	[MU Settings page]

3-2. Main Unit Linking

The Main Unit Link feature allows you to build the following link systems.

- Parallel Link:**
- Synchronous control of multiple MFR-6100 units
 - Synchronous control of one MFR-6100 and one MFR-3000
 - Synchronous control of one MFR-6100 and one MFR-5000
 - Synchronous control of one MFR-6100 and one MFR-6000

IP address and SNMP settings should be performed on each MFR-6100 unit. After these settings are completed, all linked MFR-6100 units are set and controlled together on the unit that is specified as Master.

Main Unit Link Specifications
<ul style="list-style-type: none">Main Unit Link systems are set and controlled through a specified master unit.Two MFR-6100/3000/5000/6000 units can be linked as a master and slave.All MFR main units in a system must be linked together and independent units cannot exist in the system.

3-2-1. Parallel Link System Example

The system example below is a redundant system using two MFR-6100 units.

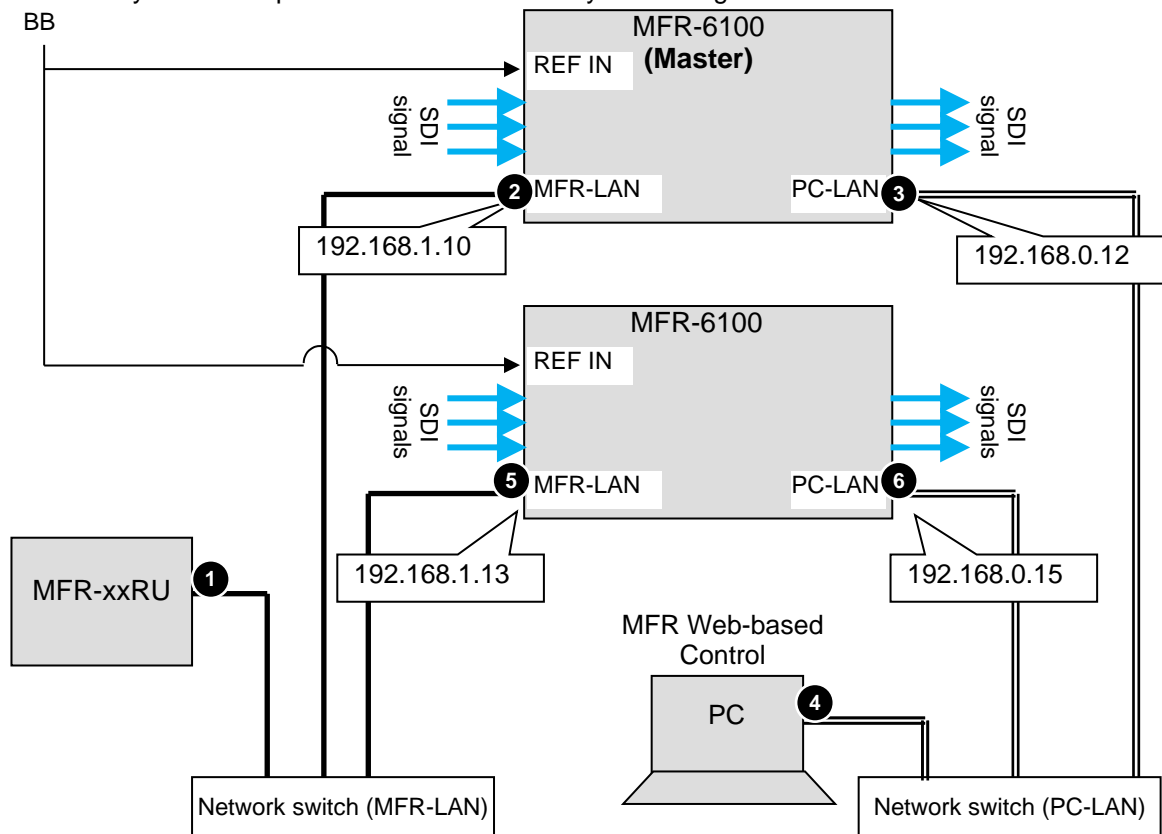

Note that in all MFR-6100 units the IP address of MFR-LAN1 is set to 192.168.1.10 and that of PC-LAN1 to 192.168.0.12 as factory default. To prevent IP address conflict in a system, you need to change IP addresses of either unit.

Also note that desired IP addresses can be set for system devices according to your network conditions.

Make sure that the MFR-LAN and PC-LAN network addresses do not conflict.

◆ **Setup Procedure**

- 1) Connect all devices in the MFR system as shown in the figure above.
Power on the MFR-6100 to be set as a Master, Remote Control unit and PC. Set the IP addresses for the Remote Control unit ① and PC ④. Power off the Master MFR-6100.
- 2) Power on the Slave MFR-6100. Set the IP addresses (⑤ and ⑥) as shown in the previous page.
- 3) Power on the Master MFR-6100.

IMPORTANT

To configure MFR-6100 units as master and slave, match the settings of their MU Settings page.

- 4) Open the Master MFR-6100 Web-based control and go to the **Build Settings** page. Check on **Build Enable** to enable the Main Unit Link feature.
 - ▶ See Sec. 11 "Main Unit Link" in the "Web-based Control User Manual."

3-3. Configuring the System with MFR-TALM

The block diagram below shows an example signal name and tally link system comprised of a FOR-A video switcher and multiviewer using an MFR-TALM unit. The MFR-TALM is specifically designed to perform the task of tally data computation, which is ordinarily undertaken by the MFR main unit, to accelerate computation. RS-422 ports (1) to (4) are available for video switcher connection.

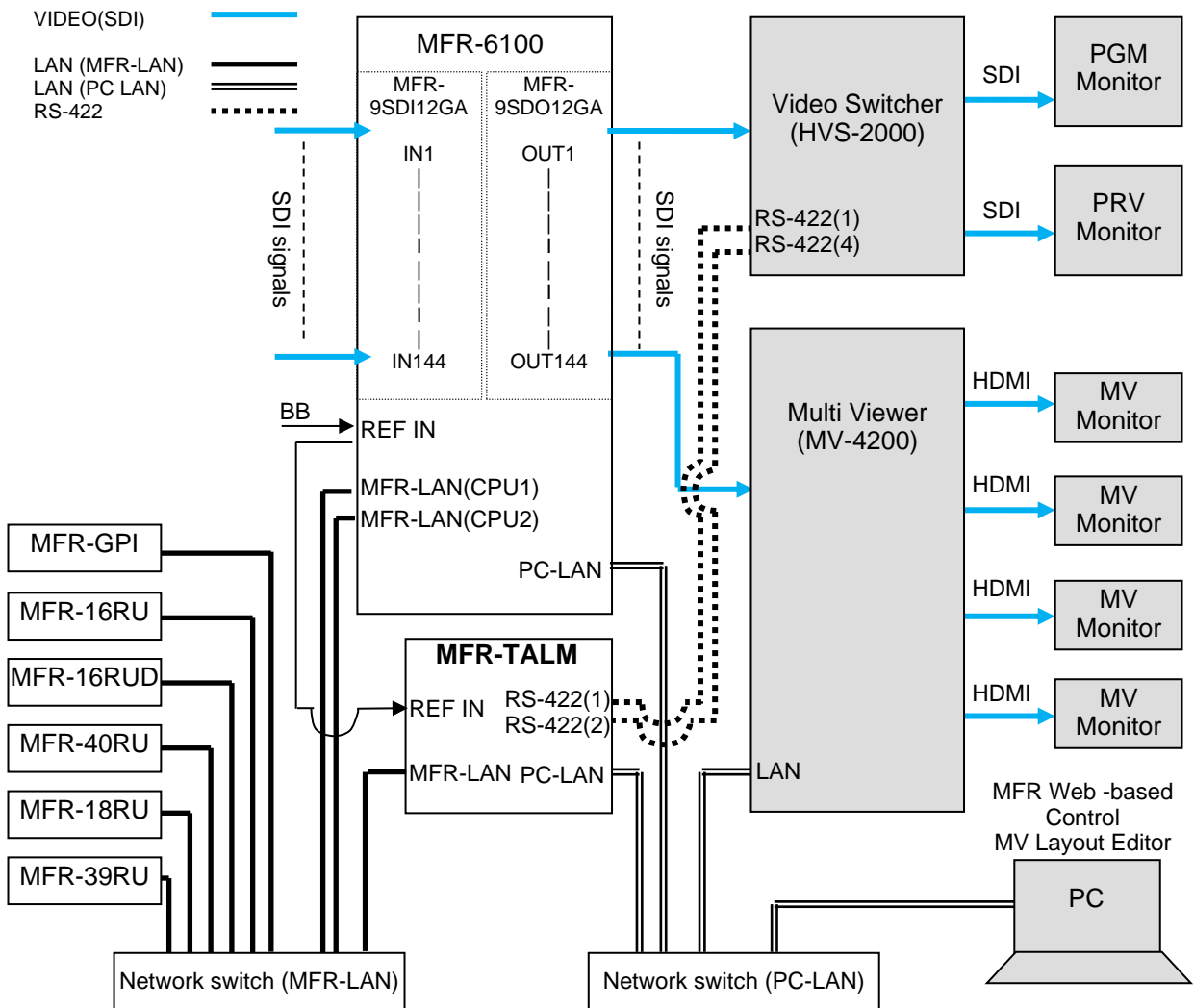

◆ **Transmitting Signal Name and Tally Data**

The figure below shows an example signal name and tally data routing system using the MFR-TALM.

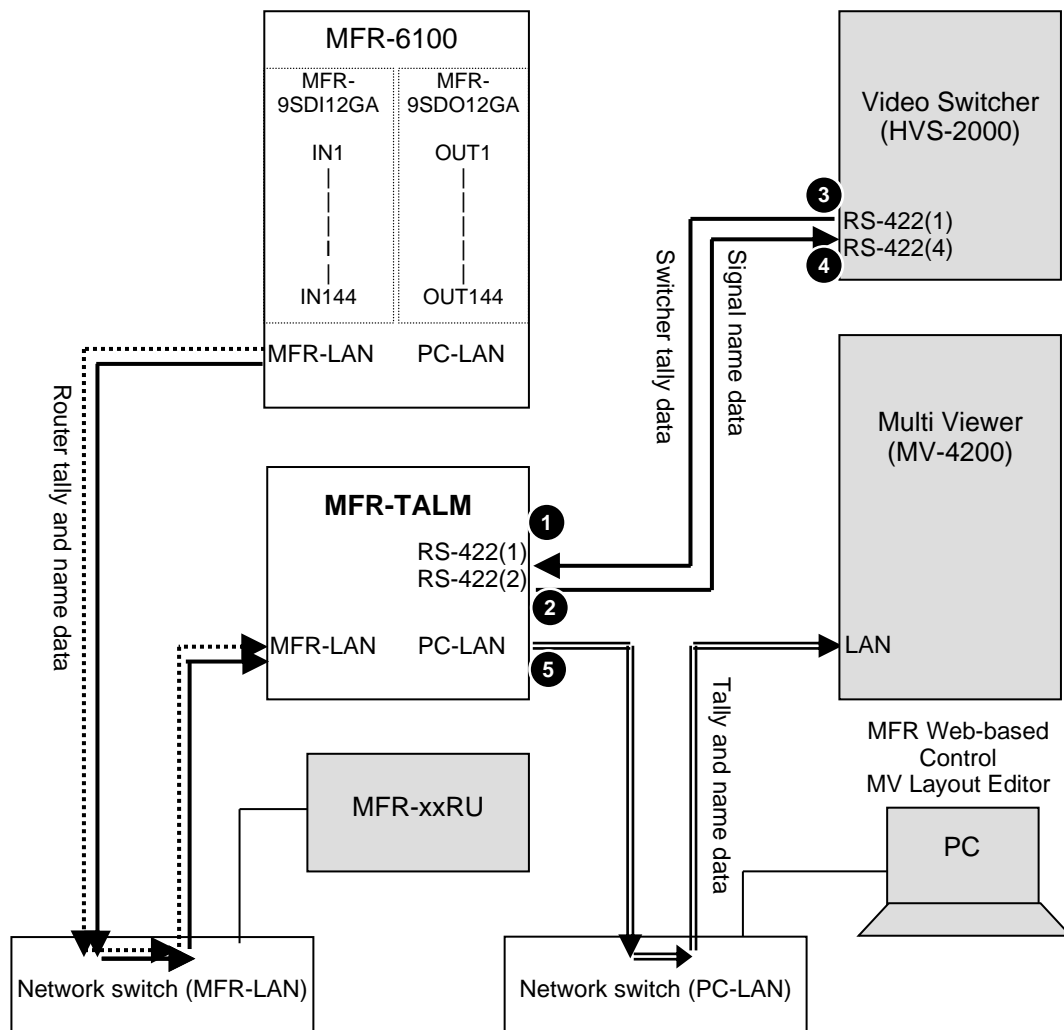

Each serial port should be set as shown in the table below in the relevant page of the **MFR-TALM** Web-based Control accessed from "<http://192.168.1.62>" (default IP address) on your web browser.

Serial Port Settings

Open the [MFR-TALM Web-based Control: **Port Settings** page] and perform port settings under **Serial Port**.

As for the HVS-2000 unit, perform port setting in the [SETUP - SYSTEM - RS-422] menu.

Port	Menu	[Port Settings] - [Serial Port]			
		Connector	Function	Baud rate	Parity
①	Web-based Control [TALM Settings]	No. 1	HVS-TAL Protocol Reception	38400	EVEN
②	Web-based Control [TALM Settings]	No. 2	Router/HVS connection Type 2	38400	NONE
③	HVS-2000 [SETUP - SYSTEM - RS-422]	No. 1	TALLY	38400	EVEN
④	HVS-2000 [SETUP - SYSTEM - RS-422]	No. 4	ROUTER	38400	NONE

TCP/IP Setting

Open the [MFR-TALM Web-based Control: **Port Settings** page] and perform port settings under **TCP/IP** Port.

Port	Menu	[Port Settings] - [TCP/IP Port]			
		Access Method	IP Address	Port	Function
5	Web-based Control [TALM Settings]	Client	(MV IP address)	(MV TCP/IP port number)	TSL UMD protocol V5.0 Tally out

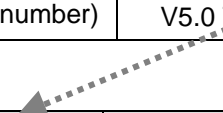

Encode	DLE	Screen No.
Unicode	ON	(Set the same as in MV)

◆ Data transmission settings between HVS-2000 and MFR-TALM

<HVS-2000-side>

- To receive name data from the router, set **LINK** in the ROUTER NAME menu to **MFR**.
- Perform the TALLY COLOR and TALLY UNIT settings so that the MFR-TALM unit can receive switcher tally data.

<MFR-TALM-side>

- Open the [MFR-TALM Web-based Control: **HVS-TAL Protocol Reception** page] and perform the same tally settings as those in HVS-2000.

Set the MFR system tally settings in the [MFR-TALM Web-based Control: **Assign Tally** page]. Refer to your multiviewer user manual for the details on how to handle tally data on the multiviewer.

3-4. Switcher's AUX Crosspoints Switching System

This system enables the following two features:

- Switches AUX crosspoints on a switcher using an MFR Series Remote Unit or serial commands.
 - Switches AUX crosspoints on a switcher as well as the corresponding crosspoints on the MFR-6100, if the MFR-6100 provides video sources to the switcher.
- Supported switcher: **HVS-390HS, HVS-100/110, HVS-2000, HVS-6000**

◆ System Example

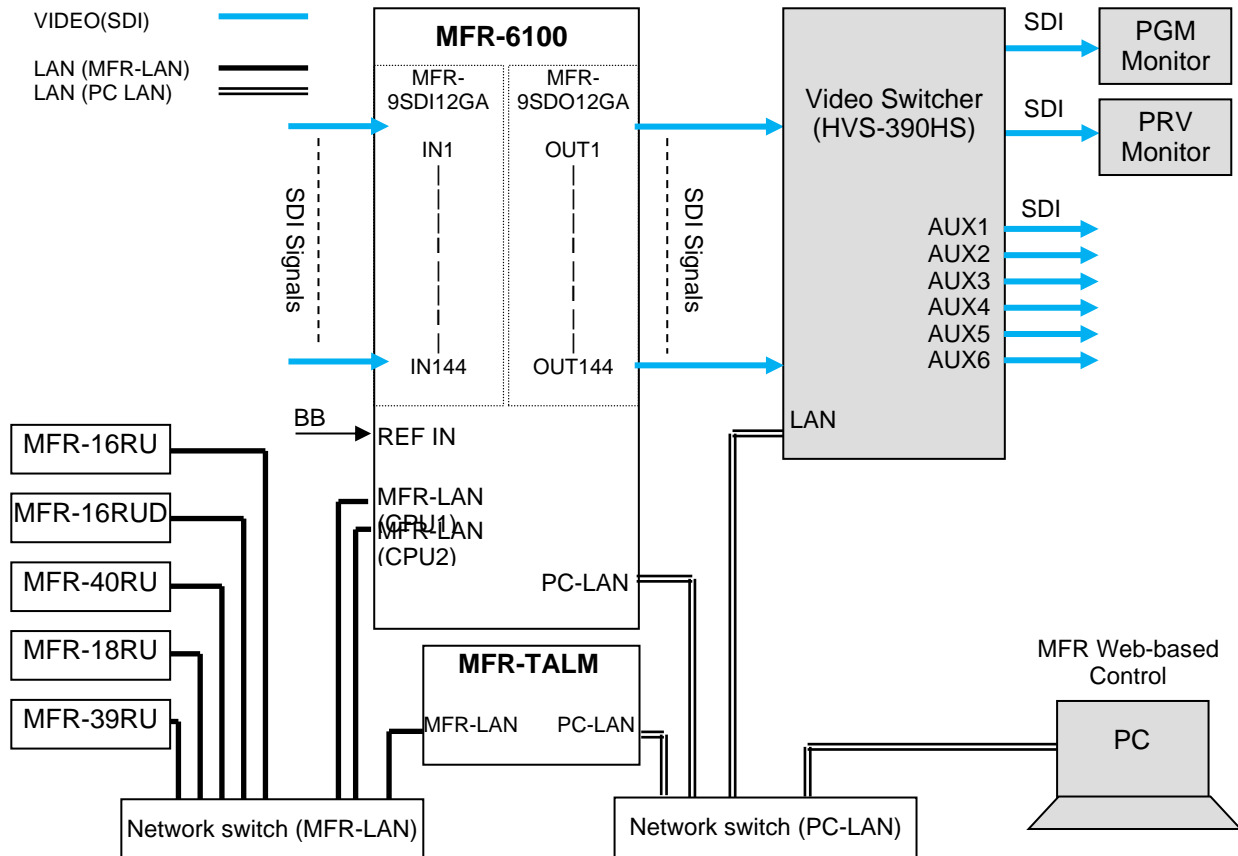

3-4-1. Switching an AUX Bus Signal

Assume that the system is configured as shown below:

AUX1 on the switcher is assigned to **DST 201** (Level 1) on the MFR-6100.

IN1-8 on the switcher are assigned to **SRC201-208** on the MFR-6100 and **STL (Still) 3** is assigned to **SRC209**.

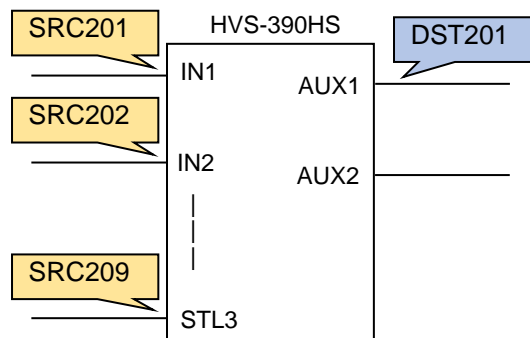

◆ **Setup Settings**

- 1) Connect and assign video signals as shown in the figure on previous page.
- 2) Device Setup on the MFR-6100:
Connect to the MFR-6100 from the Web-based Control PC and open the [**Tally System Settings - Device Select**] page. Select **HVS-390HS** in the [**Switcher**] field and click [**Send**].
- 3) Network settings on the MFR-6100:
Open the [**ROUTER SYSTEM SETTINGS - Port Settings**] page and set the TCP/IP menu as shown below.

IP Address	Port	Protocol	Function	Local Port(MFR)
(Switcher's IP address)	See below	UDP	Editor(HVS)	Select a UDP port number. Do not use the UDP port number (Default: 23) already used in the Server (MFR).

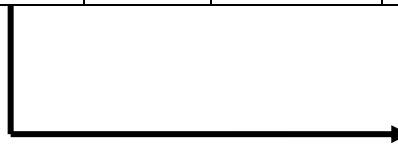

Switcher	Port
HVS-390HS	8740
HVS-100/110	8740
HVS-2000	53381
HVS-6000	53381

- 4) Assign AUX buses and input channels on the switcher to logical destination and sources channels on the MFR-6100.
<AUX bus assignments>
 - a) Open the **Destination Assignment** page.
 - b) Select HVS-390HS Table under Select Table.
 - c) Set Level to 1.
 - d) Assign AUX1 to DST 201.

<Input channel assignments>

- a) Open the **Source Assignment** page.
- b) Select HVS-390HS Table under Select Table.
- c) Set Level to 1.
- d) Assign input channels to MFR sources as shown below.

Logical No./Name	Switcher Channel
201 SRC 201	IN1
208 SRC 208	IN8
209 SRC 209	STL3

- 5) Settings on the switcher:
Open the [**SETUP - EXT I/F - EDITOR**] menu on the HVS-390HS.
Change [TYPE] to [**DVS**] and [ENABLE] to [**ON**].

After above setup settings are complete:

- If **SRC 201** is selected for **DST 201**, **AUX1** outputs **IN1** video on the switcher.
- If **SRC 209** is selected for **DST 201**, **AUX1** outputs **STL 3** on the switcher.
- If **IN4** is selected for **AUX1** on the switcher, **SRC 204** is selected for **DST 201** on the MFR-6100.

If input channels that are not assigned in the **Source Assignment** page are selected on the switcher, they are replaced with the Alternative Source set in the **Source Assignment** page in the MFR system.

3-4-2. Synchronous Crosspoints Switching

- 1) to 3) Configure the system as described in Sec. 3-4-1.
- 4) Configure channel link settings:
Open the **Re-Entry** page and set the menu page as shown below.

Output	Input
Router OUT 112	HVS-390HS IN9 > AUX 1
Router OUT 113	HVS-390HS IN10 > AUX 2

- * Physical destination channels must be assigned to these logical destination channels on the MFR-6100.

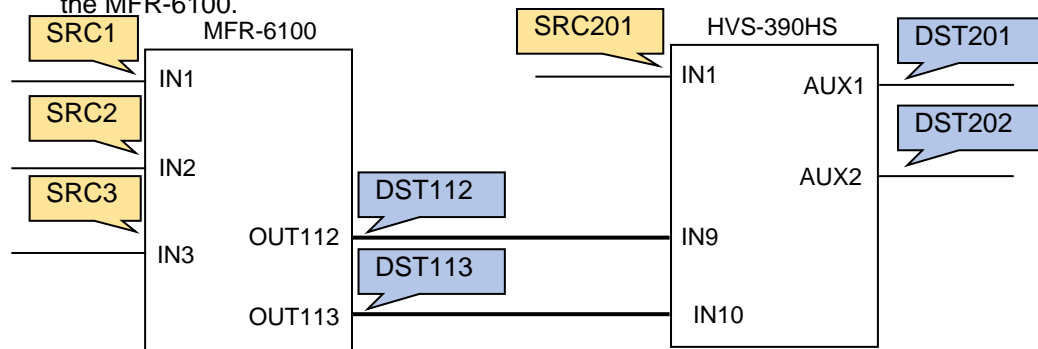

- 5) Assign logical source and destination channels on the MFR-6100 to input channels and AUX buses on the switcher.

<AUX bus assignments>

- a) Open the **Destination Assignment** page.
- b) Select HVS-390HS Table under Select Table.
- c) Set Level to 1.
- d) Assign AUX1 to DST 201.
- e) Assign AUX2 to DST 202.

<Input channel assignments>

- a) Open the **Source Assignment** page.
- b) Select HVS-390HS Table under Select Table.
- c) Set Level to 1.
- d) Assign IN1 to SRC 201.

After above setup settings are complete:

- If **SRC 201** is selected for **DST 201** on the MFR-6100, **IN1** is selected for **AUX1** on the switcher.
- If **SRC 3** is selected for **DST 201** on the MFR-6100, **IN9** is selected for **AUX1** on the switcher and **SRC 3** is also selected for **DST 112** on the MFR-6100.
- If **IN9** is selected for **AUX1** on the switcher, a source assigned to **DST 112** is selected for **DST 201** on the MFR-6100.
- If **IN10** is selected for **AUX2** on the switcher, a source assigned to **DST 113** is selected for **DST 202** on the MFR-6100.

IMPORTANT

- Note that destination channels to which physical channels are assigned (DST 112 and DST 113 in the example above) on the MFR-6100 cannot select source channels to which the switcher input channels are assigned (SRC 201 in the example above).
- If an AUX crosspoint is switched on the switcher by the Synchronous Crosspoints switching and it is not listed in Re-Entry page, the AUX crosspoint returns to the previous state.

3-5. Redundant CPU Configuration

A secondary CPU can be installed on an MFR-6100 to configure CPU redundancy. An active CPU controls the system and the other CPU monitors the system. The CPU usage state (which CPU is active) can be checked by monitoring through **Status Indicators** on the front panel, **Menu Display** or **Web-based Control**.

* Note that CPU change-over takes about 30 seconds from when an error condition occurs.

The active CPU is automatically changed in the following cases.

- When MFR-LAN is disconnected or abnormal.
- When PC-LAN is disconnected or abnormal. (*1)
- When the CPU card is abnormal.
- When the CPU card is removed.
- When you swapped active CPU.

(*1) To enable automatic CPU change when PC-LAN is disconnected or abnormal, follow the procedure below:

- (1) Open the [Web-based Control: **MFR-6100 - MU Settings**] page.
- (2) Select **Enable** under CPU Changeover.
- (3) Click **Send**.

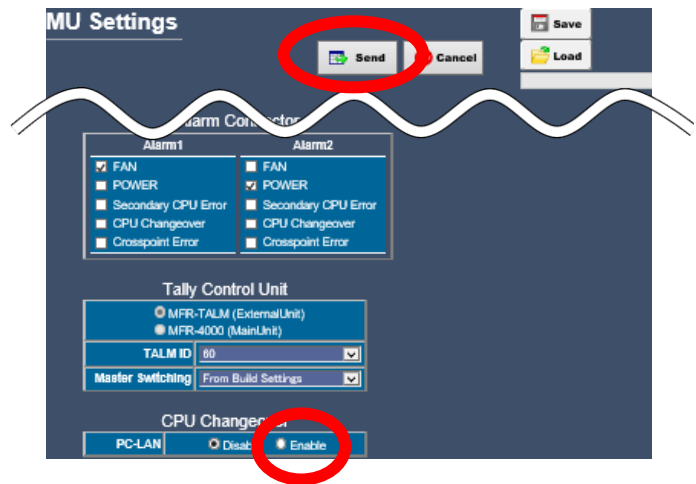

4. Menu Display Operation

Unfasten four fixing screws on the front panel and detach the front panel.

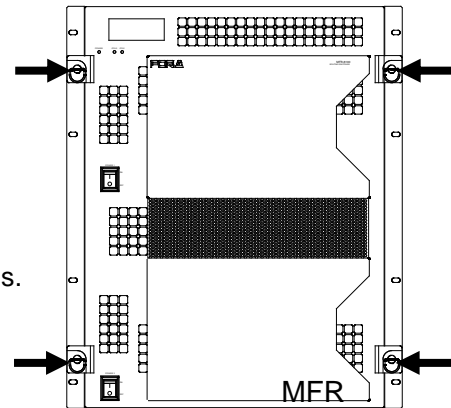

Removing the front panel reveals menu display operation buttons.

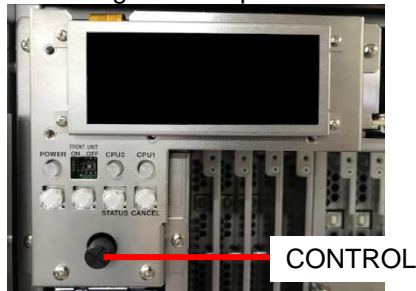

Button	Description
STATUS	Opens STATUS menu. (STATUS menu is displayed when button is lit.)
CANCEL	Lit: Displays the menu display. Unlit: Returns to a menu selection using the icons on top.
CONTROL	Turn and press CONTROL to select a menu.

Menu display is as shown below.

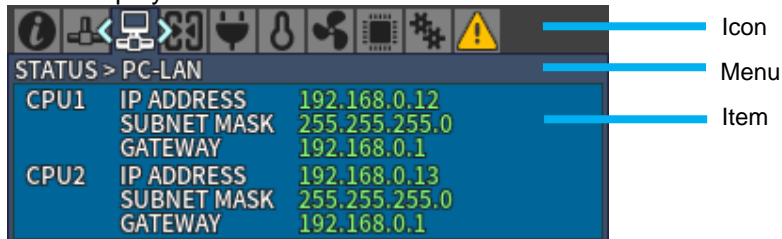

Icon	Menu	Description
	[STATUS > INFO]	System Information (See Sec. 4-1-1.)
	[STATUS > MFR-LAN]	MFR-LAN settings (See Sec. 4-1-2.)
	[STATUS > PC-LAN]	PC-LAN settings (See Sec. 4-1-3.)
	[STATUS > SLOT]	Slot status (See Sec. 4-1-4.)
	[STATUS > POWER]	Power status (See Sec. 4-1-5.)
	[STATUS > TEMPERATURE]	Temperature status (See Sec. 4-1-6.)
	[STATUS > FAN]	Fan status (See Sec. 4-1-7.)
	[STATUS > VERSION]	Version information (See Sec. 4-1-8.)
	[SETTING]	Manual switches CPU cards 1 and 2, slot shutdown and whether installed or not of the redundant power supply unit. (See Sec. 4-2.)
	[STATUS > ALARM]	Alarm information (See Sec. 4-1-9.)

4-1. STATUS

Displays various status.

“Getting...” is displayed for items acquiring data.

When ERROR is displayed, contact your supplier.



When settings are changed in each menu, the following messages are displayed. (Example below is [STATUS > INFO] menu.)

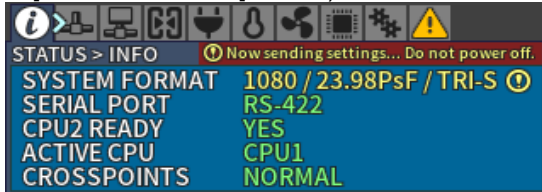

Now sending settings... Do not power off.

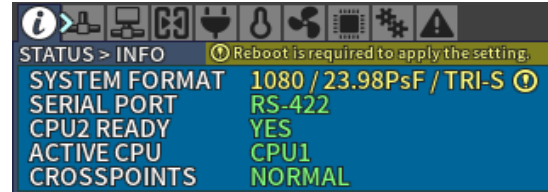

Reboot is required to apply setting.

IMPORTANT

Check items listed below when WARNING is displayed.

- Are ventilation opening on MFR-6100 secured?
- Is the ambient temperature within the operating temperature range?
- Is the AC input voltage appropriate?

4-1-1. STATUS > INFO

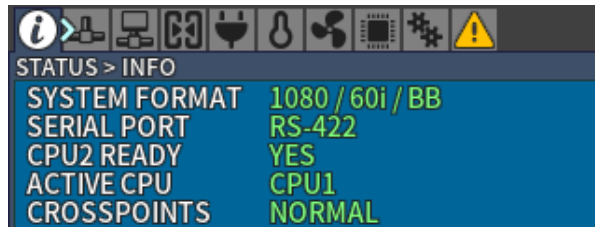

Item	Description
SYSTEM FORMAT	Resolution / Frame rate / Reference
SERIAL PORT	SERIAL port setting on rear panel - RS-232C or RS-422 .
CPU2 READY	CPU2 condition YES: Normally operating NO: Abnormal operation NOT INSTALLED: CPU2 not installed
ACTIVE CPU	CPU1 or CPU2
CROSSPOINTS	Crosspoint error status NORMAL: No error ERROR: Error (including jitter instability) state

4-1-2. STATUS > MFR-LAN

Displays MFR-LAN CPU1 and CPU2 IP and Subnet mask addresses.



4-1-3. STATUS > PC-LAN

Displays PC-LAN CPU1 and CPU2 IP, Subnet mask and Gateway addresses.

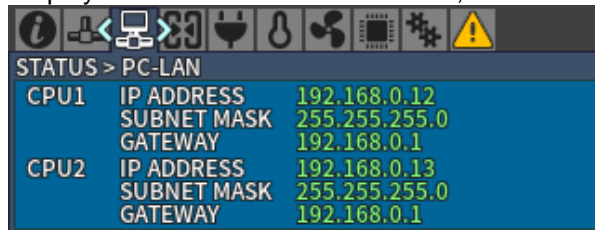

4-1-4. STATUS > SLOT

Move into [STATUS > SLOT] menu where a slot can be selected by pressing CONTROL. Select a slot by turning CONTROL to decide a slot to display the installed card information.



Item	Description
TYPE	Installed card type
FW	Firmware version
FPGA	FPGA version
POWER	Power supply status NORMAL: Normal. ERROR: Power supply error has occurred.
TEMP.	Temperature status NORMAL: Normal WARNING: Warning ERROR: Abnormal
INACTIVE(SHUTDOWN)	The slot is inactive (shutdown)
NOT INSTALLED	No card is installed into the slot

4-1-5. STATUS > POWER

Displays power supply status for each card and power supply unit.

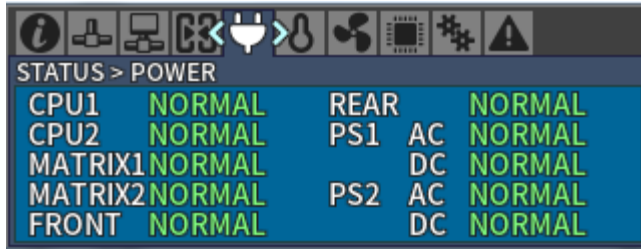

Item	Description
CPU1	NORMAL: Normal ERROR: Abnormal (*1) If MATRIX1 or MATRIX2 card has an error, turn off the card. (See Sec. 4-2-5. "Power Off for Matrix Card.")
CPU2	
MATRIX1 (*1)	
MATRIX2 (*1)	
FRONT	
REAR	
PS1 AC, DC	NORMAL: Normal ERROR: Abnormal POWER OFF: Power off
PS2 AC, DC	NORMAL: Normal ERROR: Abnormal NOT INST.: Not installed POWER OFF: Power off

4-1-6. STATUS > TEMPERATURE

Displays temperature status of each card and power supply.

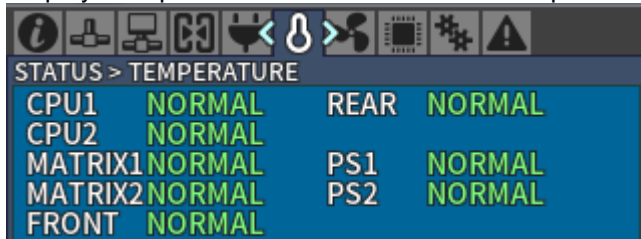

Item	Description
CPU1	NORMAL: Normal WARNING: Warning ERROR: Temperature error occurred. (*1) If MATRIX1 or MATRIX2 card has an error, turn off the card. (See Sec. 4-2-5. "Power Off for Matrix Card.")
CPU2	
MATRIX1 (*1)	
MATRIX2 (*1)	
FRONT	
REAR	
PS1	
PS2	

4-1-7. STATUS > FAN

Status of MFR-6100 rear fan (REAR 1-6) and power supply fan (PS1-2) units.

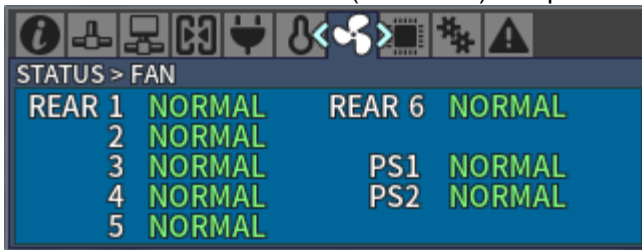

Item	Description
REAR 1-6	NORMAL: Normal
PS1-2	WARNING: Warning ERROR: Fan error

4-1-8. STATUS > VERSION

Displays FW (Firmware), FPGA and CPLD versions for each card.



4-1-9. STATUS > ALARM

When an alarm has occurred, ALARM icon is displayed in yellow and the part name indicating an alarm is displayed in red.

Example) Display when a PS2 (Power Supply Unit 2) power supply alarm has occurred.

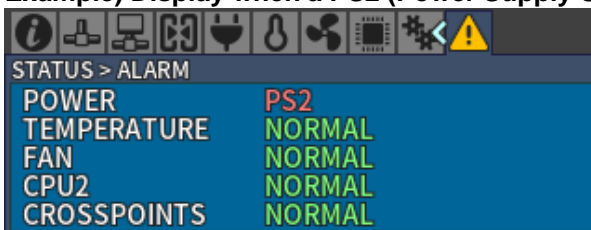

Item	Description
POWER	Displays where a power alarm has occurred.
TEMPERATURE	Displays where a temperature alarm has occurred.
FAN	Displays where a fan alarm has occurred.
CPU2	Displays that a CPU2 alarm has occurred.
CROSSPOINTS	Displays crosspoints alarm(s) and MTX FPGA alarm have occurred.

4-2. SETTING

Turn CONTROL to select a menu to change settings and press CONTROL to enter the settings screen.



Menu	Description
SWAP ACTIVE CPU	Allows you to verify CPU condition and manually swap the active CPU.
SLOT SHUTDOWN	Allows you to turn on/off an in/out card.
POWER SUPPLY 2	Allows you to verify power supply 2 installation and change settings.
FRONT DISPLAY	Allows you to change front menu display settings.
MTX SHUTDOWN	Allows you to turn off a matrix card.
CPU1 REBOOT	Allows you to reboot CPU1.

4-2-1. Swapping Active CPU

- 1) Open [SETTING > SWAP ACTIVE CPU] menu. Confirm that **READY FOR SWAP** is set to **YES**.

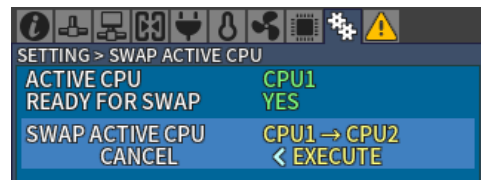

When **READY FOR SWAP** is set to **NO**, a message appears as shown in the right figure.

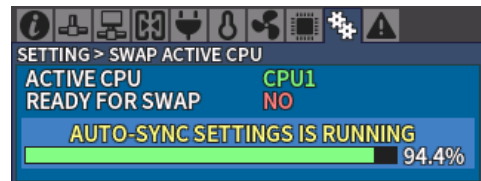

Message	Description
THE OTHER CPU IS NOT INSTALLED	A redundant CPU is not installed.
THE OTHER CPU HAS AN ERROR	The redundant CPU is not functioning.
AUTO-SYNC SETTINGS IS RUNNING	Synchronizing settings with the redundant CPU. Wait until status bar reaches 100%.

- 2) Turn and press CONTROL to select **EXECUTE** in SWAP ACTIVE CPU. A message **Now Executing...** is displayed while a swap is executed.

4-2-2. Turning ON/OFF an Input/ Output Card

Example) Turning OFF the INPUT1 slot.

1. Open the [SETTING > SLOT SHUTDOWN] menu.
2. Turn and press CONTROL to select **INPUT1** in TARGET SLOT.



- Turn and press CONTROL to select **EXECUTE** in CHANGE STATE. A **Now Executing...** message is displayed.
- When **SHUTDOWN** is displayed, slot shutdown is complete.

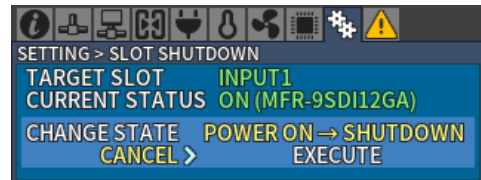

Example) Turning ON the INPUT5 slot.

- Open [SETTING > SLOT SHUTDOWN] menu.
- Turn and press CONTROL to select **INPUT5** in TARGET SLOT.
Confirm that CURRENT STATUS is displayed as **SHUTDOWN**.

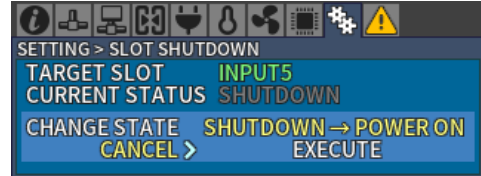

- Turn and press CONTROL to select **EXECUTE** in CHANGE STATE.
A message **Now Executing...** is displayed.
- When **ON** is displayed for CURRENT STATUS, turning on slot power is complete.

NOTE

When **NOT INSTALLED** is displayed for CURRENT STATUS, the slot power is not able to power ON/OFF.

4-2-3. Changing Power Supply 2 Installation Status

Open the [SETTING > POWER SUPPLY 2] menu to check and change Power Supply 2 installation status.

Whether or not Power Supply 2 is installed can be checked by verifying whether the SETTING > POWER SUPPLY 2 Menu is INSTALLED / NOT INSTALLED

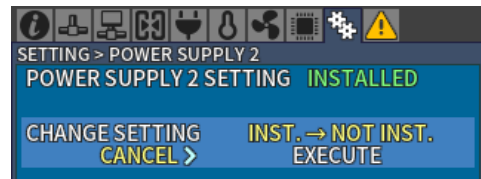

To change Power Supply 2 installation status, turn CONTROL, select EXECUTE in the CHANGE SETTING Menu and press CONTROL.

A message "**Now Executing...**" appears. When the message disappears, the setting is complete.

4-2-4. Changing Menu Display Settings

Open the [SETTING > FRONT DISPLAY] menu to change MFR-6100 menu display settings. When the menu is not displayed, press the **CANCEL** button to display the menu.



Changing Menu Display Brightness

1. Open the [SETTING > FRONT DISPLAY] menu.
2. Turn and press CONTROL to select **BRIGHTNESS**.
3. Turn and press CONTROL to select the brightness level from 00 (dim) to 15 (bright). (Factory default: **12**)
4. Turn and press CONTROL to select **EXECUTE** under the CHANGE SETTING.
If **CANCEL** is selected under the CHANGE SETTING and CONTROL is pressed, the display returns to the [SETTING > FRONT DISPLAY] menu without executing the change.

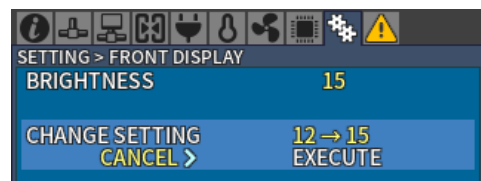
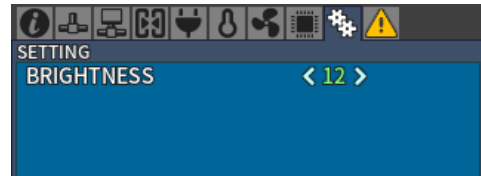

The Menu display contrast can also be adjusted following the above procedure but by selecting **CONTRAST**.

Setting range: 00 (weak) to 15 (strong) (Factory default: **13**)

Hiding Menu Display

1. Open the [SETTING > FRONT DISPLAY] menu.
2. Turn and press CONTROL to select **DISPLAY OFF**.
3. Turn and press CONTROL to select **EXECUTE** under the CHANGE SETTING.
Menu Display is hidden.
If **CANCEL** is selected under CHANGE SETTING and CONTROL is pressed, the display returns to the [SETTING > FRONT DISPLAY] menu without executing the change.
4. If the **CANCEL** button is pressed, Menu Display reappears.



* Menu Display Settings before turning off the power are retained when re-starting the unit.

4-2-5. Power Off for Matrix Card

If any failure occurs in a matrix card, turn off the card to protect it.

When the matrix card is turned off, no image outputs.

To turn on the matrix card, restart the main unit.

If a serious failure occurs in the matrix card, it is automatically powered off.

- (1) Open the [SETTING > MTX SHUTDOWN] menu.
Check that MTX STATUS shows WARNING or ERROR.

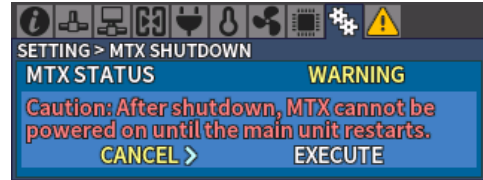

If MTX STATUS is NORMAL, the matrix card cannot be powered off.

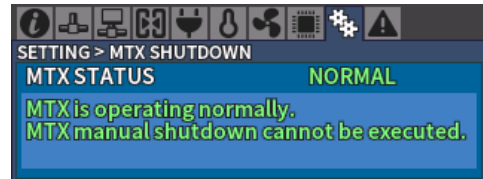

If MTX STATUS shows SHUTDOWN, the matrix card is already powered off.

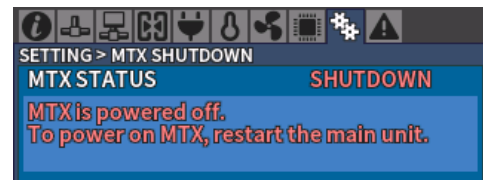

- (2) Turn the CONTROL to select **EXECUTE**, then press the CONTROL.
A message "Now Executing..." appears then the matrix card becomes powered off.

4-2-6. Rebooting CPU1

In CPU redundant configuration, CPU1 can be rebooted when CPU2 is active.

- (1) Open the [SETTING > CPU1 REBOOT] menu. (Effective only when CPU2 is active.)
- (2) Verify that READY FOR REBOOT is set to **YES**.



Note that CPU1 cannot reboot when CPU1 is rebooting or has an error.

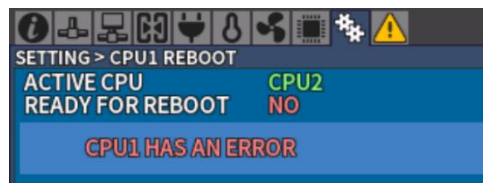

If CPU1 is not installed, a message shown at right appears.

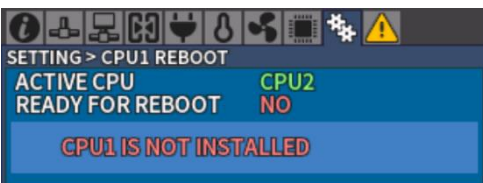

- (3) Turn CONTROL to select **EXECUTE**, then press CONTROL. The message "Now Executing..." appears and CPU1 starts to reboot.

5. Serial / LAN Command Control

Up to 20 external devices can be connected to an MFR Main Unit (including MFR-GPI serial ports) through LAN or serial interface. The maximum number of allowed LAN connections is **16**.

5-1. Serial Control

Crosspoint switchover, destination locks and other operations can be performed via serial ports on the MFR Series main unit or SERIAL port 1-4 on the MFR-GPI.

5-2. LAN Control

The MFR Series main unit is able to connect to a third-party automatic control system via the RJ-45 port (PC-LAN port). The TCP/IP communication protocol is supported. The control PC will be the Client, and the MFR Series main unit will be the Server.

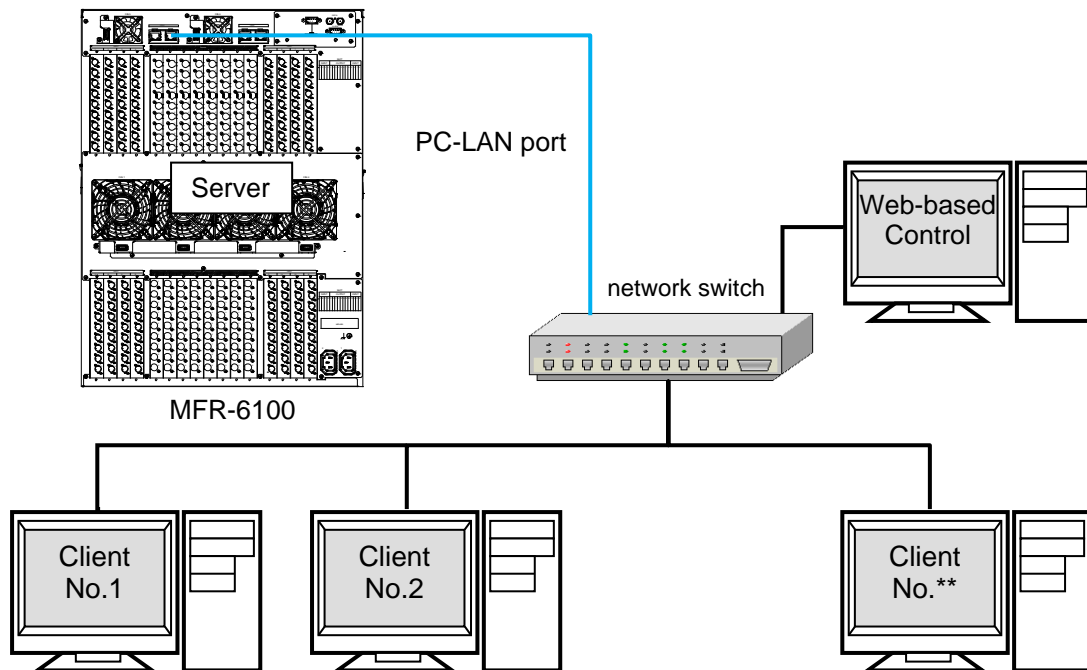

◆ Basic specifications

Item	Description
IP address (PC-LAN port)	Primary LAN (PC-LAN CPU1) default IP address: 192.168.0.12 Secondary LAN (PC-LAN CPU2) default IP address: 192.168.0.13* (Subnet Mask: 255.255.255.0)
Port number	Setting range: 23, 49152 to 65534 (default: 23)
Number of PCs	Max. 16
Response / Resend	Wait before sending next command (Resend if the Echo is not returned.)
Login password	None
Communication protocol	TCP/IP, Control PC: Client, MFR-6100: Server Crosspoint Remote Control using ASCII code.
Command protocol	Crosspoint Remote Control protocol

* When a redundant CPU is configured, a client should connect to both LAN ports (PC-LAN CPU1 and PC-LAN CPU2) and send commands to the ports respectively. When the system functions normally, the secondary port (PC-LAN CPU2) do not respond to commands. But if an error occurs in the CPU1 system, the secondary port will take over the primary port and respond to commands.

5-3. Control Commands

Although the protocols listed below support both serial and LAN connections, some commands can only be sent over a LAN.

◆ Control command list

	Function	Serial	LAN *1	Protocol *2
1	Commands (S?) for requesting the crosspoints list	Yes	Yes	Crosspoint remote control / Crosspoint remote control 2
2	Commands (X?) for requesting information on crosspoints (by specifying a destination and level.)	Yes	Yes	
3	Commands (X:) for switching over a crosspoint (single channel)	Yes	Yes	
4	Commands for switching over crosspoints (multi-channel simultaneous switchover)	Yes	Yes	
5	Commands (W:) for locking a destination	Yes	Yes	
6	Commands (Z:) for reinitializing a unit	Yes	Yes	
7	Commands (K?) for requesting input/output channel names	-	Yes	Crosspoint remote control 2
8	Commands (A?) for requesting CPU status.	-	Yes	
9	Commands (W?) for requesting Destination Lock status.	-	Yes	
10	Commands (K:) for importing signal names	-	Yes	
11	Commands for setting video format (reference and/or switching point).	-	Yes	
12	Commands for swapping active CPU.	-	Yes	

*1 When commands are sent via LAN, an Echo, Prompt, S response and other response messages may be included in a single packet or divided into two or more packets. Therefore, do not process commands in a per packet basis but a per stream basis.

*2 A command protocol should be selected in the [Web-based Control: **Port Settings** page].

◆ Command formats

Func.	Control command	Command response	Ref.
1	@[sp]S?<Lvl>	S:<Lvl><Dest>,<Src>	-
2	@[sp]X?<Lvl><Dest>	S:<Lvl><Dest>,<Src>	-
3	@[sp]X:<Lvls>/<Dest>,<Src>	S:<Lvl><Dest>,<Src> C:<Lvls>/<Dest>,<Src>[.....[S<Salvo number>]][L<Link number>]]:l<ID>	-
4	Clear a preset crosspoint. @[sp]B:C		-
	Preset a crosspoint. @[sp]P:<Lvl>/<Dest>,<Src>		
	Read a preset crosspoint specifying a level and destination. @[sp]P?<Lvl><Dest>	V:<Lvl><Dest>,<Src>	
	Read preset crosspoints for all channels in the specified level. @[sp]V?<Lvl>	V:<Lvl><Dest>,<Src>	
	Perform the preset crosspoints simultaneously. @[sp]B:E	S:<Lvl><Dest>,<Src> C:<Lvls>/<Dest>,<Src>[.....[S<Salvo number>]][L<Link number>]]:l<ID>	-
5	LOCK ALL units. @[sp]W:<Lvl>/<Dest>,<ID>,1	W!<Lvl><Dest>,<ID>,1	-
	LOCK OTHER units. @[sp]W:<Lvl>/<Dest>,<ID>,2	W!<Lvl><Dest>,<ID>,2	-
	Disable LOCK. @[sp]W:<Lvl>/<Dest>,<ID>,0	W!<Lvl><Dest>,<ID>,0	-
6	@[sp]Z:<Lvls>	S:<Lvl><Dest>,<Src> C:<Lvls>/<Dest>,<Src>[.....[S<Number of crosspoints in Salvo>]]:l<ID>	
7	@[sp]K?<SorD><AorK>,<Offset>	K:<SorD><AorK><No.>,<Dat>	5-3-3

8	@[sp]A?	If CPU is active:	A:<ID>	5-3-4
		If CPU is passive:	(No response)	
9	@[sp]W?<Lvl>,<Dest>		W!<Lvl><Dest>,<ID>,0-2	5-3-5
10	K:<S or D><S or L or A><No.>,<Dat>			5-3-6
11	Sets video format (reference and/or switching point) settings. @[sp]UF:<YY>/<R#>,<S\$>		UF!<YY>/<R#>,<S\$>	5-3-7
	Performs the settings. @[sp]UE:A		UR!W UR!<YY>/<R#>,<S\$> UR!E (Error response)	
	Cancels the settings. @[sp]UE:C		UR!C	
12	Sets CPU swap settings. @[sp]FC:P		FC!P	5-3-8
	Performs the settings. @[sp]FE:A		FR!W FR!E (Error response)	
	Cancels the settings. @[sp]FE:C		FR!C	

* [sp] indicates a space.

* Commands must end with a carriage return (ASCII code 0x0D) only or carriage return and line feed (ASCII code 0x0A). MFR units add a **carriage return** and **line feed** in front of and at the end of reply messages.

◆ Command parameters and setting range

<Lvl>	0-7	Allows you to specify the level to switch crosspoints. * When in single-level operation.
<Lvls>	0-7	Allows you to specify the levels to switch crosspoints. * When in multiple-level operation
<Dest>	0-1FF	Allows you to specify the crosspoint switchover destination.
<Src>	0-3FF	Allows you to specify the source of crosspoint switchover.
<ID>	0-FE	Unit ID. Set a number that does not conflict with the IDs of other models connected to the same network. Use 1 to FE for ID numbers. The host returns 0 when the lock is released.

* All command values are in hexadecimal, starting from 0 (zero).
(For example, Source "16" is represented as <Src>"F.")

* If levels are not in use, set <Lvl> or <Lvls> to "0"(zero).

5-3-1. Command Responses (Commands 1-6)

• Echo and Prompt

Responses will be sent as shown below when receiving commands:

Receipt of command	
↓	
Echo	@[sp]X:<Lvls>/<Dest>,<Src>[CR]
↓	
Prompt	[CR][LF]>

* MFR units respond with an Echo Reply with the same data received. Therefore, echo reply messages end with [CR] [LF] or [CR] only. If echo messages with [CR] [LF] are received, only [LF] composes the second line.

* MFR units read a command, ended with a newline, and return a prompt to notify that they are ready to receive a new command.

* A carriage return and line feed are not added at the end of "Echo Reply" or "Prompt"

- **“C” responses**

A “C” response is sent as shown below when a control command is received:

```
[CR][LF]C:<Lvl>/<Dest>,<Src>[...S<Salvo number>][L<Link number>]:!<ID>[CR][LF]
```

* C responses are sent to all terminals in the system.

Parameter	Setting range	Description
<Salvo number>	1-FFF	The number of crosspoints to be changed simultaneously by Salvo settings. A response if 3 crosspoints are to be changed simultaneously: C:0/0,0...S2:IA
<Link number>	1-FFF	The number of crosspoints to be changed simultaneously by Link settings. A response if 2 crosspoints are to be changed simultaneously: C:0/0,2...L1:IA

- **“S” responses**

An “S” response is sent as shown below when crosspoints are switched by a command.

```
[CR][LF]S:<Lvl><Dest>,<Src>[CR][LF]
```

* If a crosspoint is switched by an X or B command, its “S” response is sent to all terminals in the system. However, if any crosspoints are not switched (specifying the same crosspoint as the current one), its “S” response is sent only to the terminal that sent the command.

* C responses are sent before S responses in some cases.

* When a command is received from another terminal while a B or X command is processed, MFR units send “S” response messages to the terminals, notifying only the latest crosspoint states.

* A crosspoint switch command is not performed if the relevant crosspoint is locked or inhibited from changing.

Ex. 1 When Source 5 is selected for Destination 3 in Level 1:

(Function 3 in the previous page)

(A)	@ X:0/2,4[CR] [CR][LF]>	Terminal display:	@ X:0/2,4
(B)	[CR][LF] C:0/2,4:IA[CR][LF]		>
(C)	[CR][LF] S:02,4[CR][LF]		C:0/2,4:IA
			S:02,4

Ex. 2 When Source 113 is selected for Destination 49 in Levels 2 to 7:

(Function 3 in the previous page)

(A)	@ X:123456/30,70[CR] [CR][LF]>	Terminal display:	@ X:123456/30,70
(B)	[CR][LF] C:123456/30,70...S5:IA[CR][LF]		>
(C)	[CR][LF] S:130,70[CR][LF]		C:123456/30,70...S5:IA
(C)	[CR][LF] S:230,70[CR][LF]		S:130,70
(C)	[CR][LF] S:330,70[CR][LF]		S:230,70
(C)	[CR][LF] S:430,70[CR][LF]		S:330,70
(C)	[CR][LF] S:530,70[CR][LF]		S:430,70
(C)	[CR][LF] S:630,70[CR][LF]		S:530,70
(C)	[CR][LF] S:630,70[CR][LF]		S:630,70

* [CR] and [LF] represent Carriage Return (0x0D) and Line Feed (0x0A) respectively.

5-3-2. Receiving Responses (Commands 1-6)

- **Timeout Period for Response Commands from MFR**

Set the **timeout** period (maximum permitted time until its response returns from the MFR unit) to **1 second** for short message commands and to **5 seconds** for long message commands. For CPU changeover commands, set the **timeout** period to **15 seconds**.

- **If Sending Commands Successively:**

- For "X:", "B:C", "P:" and "W:" commands, send the next command **after** a **prompt** returns.

- For "S?", "X?", "P?", "V?", "B:E" and "Z:" commands, send the next command **after** a **prompt and reply messages** return.

- For "S?" and "Z:" commands as well as "V?" and "B:E" commands after executing many preset commands, send the next command **after** having finished receiving **all strings** of reply messages.

Ex. 1)

Allows the next command to be sent when receiving a prompt.

Resends the previous command when the timeout period (5 seconds) has elapsed without reply after sending a command.

Ex. 2)

Allows the next command to be sent when receiving a prompt.

Resends the previous command when the timeout period (5 seconds) has elapsed without reply after sending a command.

Recognizes and uses "S" responses as tallies (crosspoint states).

Ex. 3)

Allows the next command to be sent when receiving a prompt.

Recognizes and uses "S" responses as tallies (crosspoint states).

Resends the previous command when the timeout period (5 seconds) has elapsed without reply after sending a command.

Sets the maximum number of continuous resends, because crosspoints cannot be changed if they are locked or inhibited from changing.

Ex. 4)

Allows the next command to be sent when receiving a prompt.

Resends the previous command when the timeout period (5 seconds) has elapsed without reply (echo) after sending a command.

Ex. 5)

Allows the next command to be sent when receiving a prompt if tally or echo recognition is not performed.

Ex. 6)

Allows the next command to be sent when receiving a prompt.

Resends the previous command regarding as timeout, when the timeout period (5 seconds) or more has elapsed after sending a command.

Sends the CPU changeover command to CPU2 regarding as CPU1 error, when 15 seconds or more have passed after sending a command.

• **Response Message Evaluation Example:**

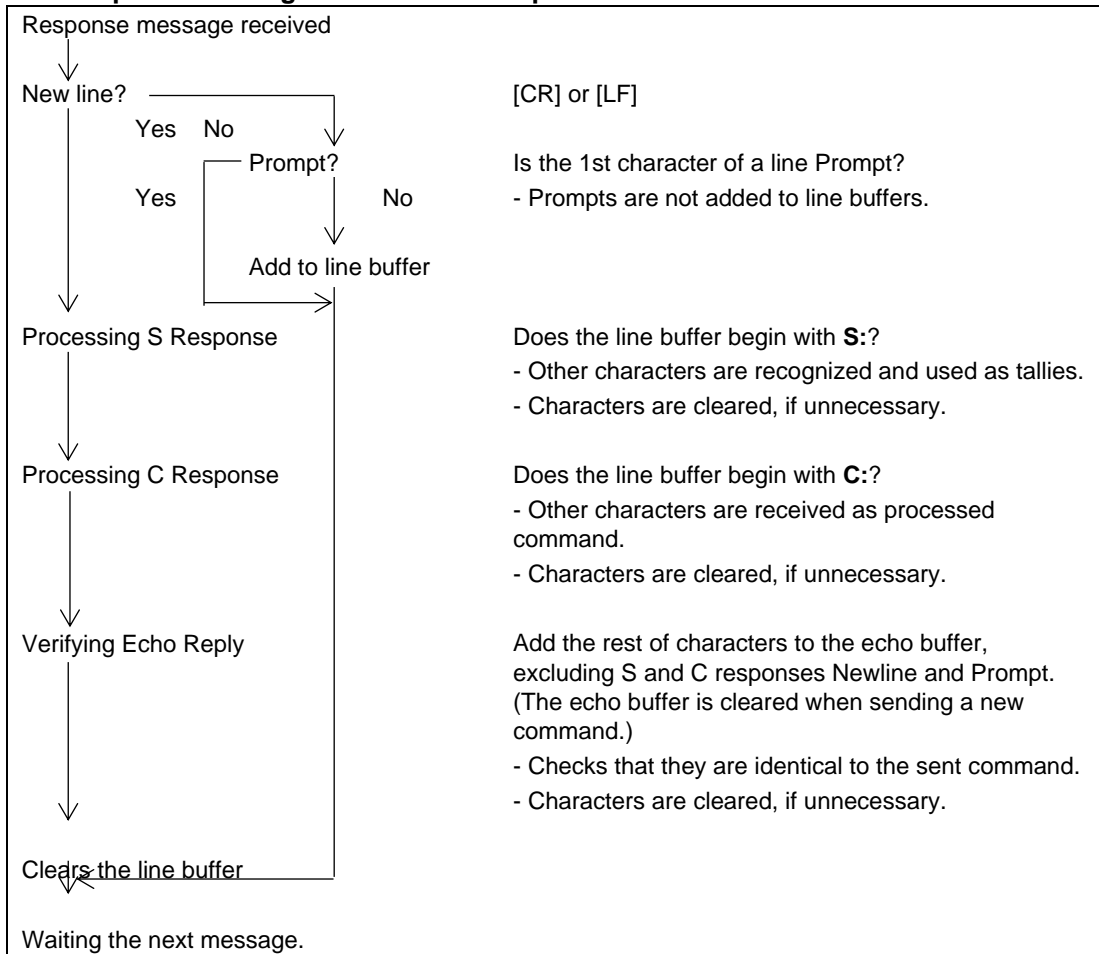

[CR] or [LF]

Is the 1st character of a line Prompt?
 - Prompts are not added to line buffers.

Does the line buffer begin with **S**:?
 - Other characters are recognized and used as tallies.
 - Characters are cleared, if unnecessary.

Does the line buffer begin with **C**:?
 - Other characters are received as processed command.
 - Characters are cleared, if unnecessary.

Add the rest of characters to the echo buffer, excluding S and C responses Newline and Prompt. (The echo buffer is cleared when sending a new command.)
 - Checks that they are identical to the sent command.
 - Characters are cleared, if unnecessary.

- **If Commands Overlap:**

Two or more commands are sent from different terminals (via serial or LAN interface, or Remote Control units), all command results (C and S responses) are returned to all these terminals from the MFR.

The following command examples show how overlapped commands are processed.

Ex.) Assume that the following commands are overlapped:

Terminal 1 sent "@ X:0/2,4."

Terminal 2 sent "@ X:123456/30,70."

Message examples returned to Terminal 1

1-(A)	@ X:0/2,4[CR] [CR][LF]>
1-(B)	[CR][LF] C:0/2,4:IA[CR][LF]
2-(B)	[CR][LF] C:123456/30,70...S5:IA[CR][LF]
1-(C)	[CR][LF] S:02,4[CR][LF]
2-(C)	[CR][LF] S:130,70[CR][LF]
2-(C)	[CR][LF] S:230,70[CR][LF]
2-(C)	[CR][LF] S:330,70[CR][LF]
2-(C)	[CR][LF] S:430,70[CR][LF]
2-(C)	[CR][LF] S:530,70[CR][LF]
2-(C)	[CR][LF] S:630,70[CR][LF]

Terminal display:

```
@ X:0/2,4
>
C:0/2,4:IA
C:123456/30,70...S5:IA
S:02,4
S:130,70
S:230,70
S:330,70
S:430,70
S:530,70
S:630,70
```

Message examples returned to Terminal 2

2-(A)	@ X:123456/30,70[CR] [CR][LF]>
1-(B)	[CR][LF] C:0/2,4:IA[CR][LF]
2-(B)	[CR][LF] C:123456/30,70...S5:IA[CR][LF]
1-(C)	[CR][LF] S:02,4[CR][LF]
2-(C)	[CR][LF] S:130,70[CR][LF]
2-(C)	[CR][LF] S:230,70[CR][LF]
2-(C)	[CR][LF] S:330,70[CR][LF]
2-(C)	[CR][LF] S:430,70[CR][LF]
2-(C)	[CR][LF] S:530,70[CR][LF]
2-(C)	[CR][LF] S:630,70[CR][LF]

Terminal display:

```
@ X:123456/30,70
>
C:0/2,4:IA
C:123456/30,70...S5:IA
S:02,4
S:130,70
S:230,70
S:330,70
S:430,70
S:530,70
S:630,70
```

* C responses are sent before S responses in some cases.

5-3-3. Channel Name Request Commands (7)

K? commands allow you to obtain Source and Destination names in ASCII and/or in Kanji set in the MFR Web-based Control menu.

◆ Command Format

Command	Command response
@[sp]K?<S or D><A or K>,<Offset>	K:<SorD><AorK><No.>,<Dat>

BYTE No.	1	2	3	4	5	6	7	8-10	11
Command	@	[sp]	K	?	S	A	,	000-3FF	CR
					D	K		000-1FF	

BYTE No.	1	2	3	4	5	6	7-9	10	11-		
Response	CR	LF	K	:	S	A	000-3FF	,		CR	LF
					D	K	000-1FF				

Command Response	BYTE 5	<S or D> Select between S (Source) or D (Destination) S: Source, D: Destination
	BYTE 6	<A or K> Select A (ASCII) or K (Kanji) for names.
Command	BYTE8-10	<Offset> Specify the start number of channels. Source: 000-3FF, Destination: 000-1FF
Response	BYTE7-9	<No.> Indicates the channel number. Source: 000-3FF, Destination: 000-1FF
Response	BYTE11-	<Dat> Indicates the short or long channel name using hex characters (max. 128 bytes). Character code for ASCII names: ASCII Character code for Kanji names: UTF-8
Command Response	CR	Carriage return
	LF	Line feed

Up to 32 channel names can be obtained per request.

Note that if the number of request channels exceeds the system maximum size, no data will return for the exceeded channels. Set the system size in [Web-based Control: SystemSize / LevelName - SystemSize].

► See the [Web-based Control: **SystemSize / LevelName** page].

◆ **Command Example 1: Requesting the Source Channel 1 ASCII Name**

➤ **Web-based Control (Source Name menu)**



➤ **Terminal display**

Command	@ K?SA,000
---------	------------

Response	@ K?SA,000	Echo
	K:SA000,5352432031	ASCII Name for Source Channel 1 is SRC 1.
	K:SA001,5352432032	ASCII Name for Source Channel 2 is SRC 2.
	K:SA002,5352432033	ASCII Name for Source Channel 3 is SRC 3.
	K:SA01F,5352433332	ASCII Name for Source Channel 32 is SRC32.
	>	Prompt

➤ **Response details**

K:	S	A	000,	53	52	43	20	31
	Source	ASCII	Channel 1	S	R	C	[sp]	1

◆ **Command Example 2: Requesting the Destination Channel 101 Kanji Name**

➤ Web-based Control (Destination Name menu)

➤ Terminal display

Command	@ K?DK,064
---------	------------

Response	@ K?DK,064	Echo
	K:DK064,E587BAE58A9BEFBC91EFBC90EFBC91	Kanji Name for Destination Channel 101 is 出力 1 0 1.
	K:DK065,E587BAE58A9BEFBC91EFBC90EFBC92	Kanji Name for Destination Channel 102 is 出力 1 0 2.
	K:DK066,E587BAE58A9BEFBC91EFBC90EFBC93	Kanji Name for Destination Channel 103 is 出力 1 0 3.
	K:DK083,E587BAE58A9BEFBC91EFBC93EFBC92	Kanji Name for Destination Channel 132 is 出力 1 3 2.
	>	Prompt

➤ Response details

K:	D	K	064,	E587BA	E58A9B	EFBC91	EFBC90	EFBC91
	Destination	Kanji	Channel 101	出	力	1	0	1

K:	D	K	065,	E587BA	E58A9B	EFBC91	EFBC90	EFBC92
	Destination	Kanji	Channel 102	出	力	1	0	2

◆ **Command Example 3: Requesting the Source Channel 65 Kanji Name**

➤ **Web-based Control (Source Name menu)**

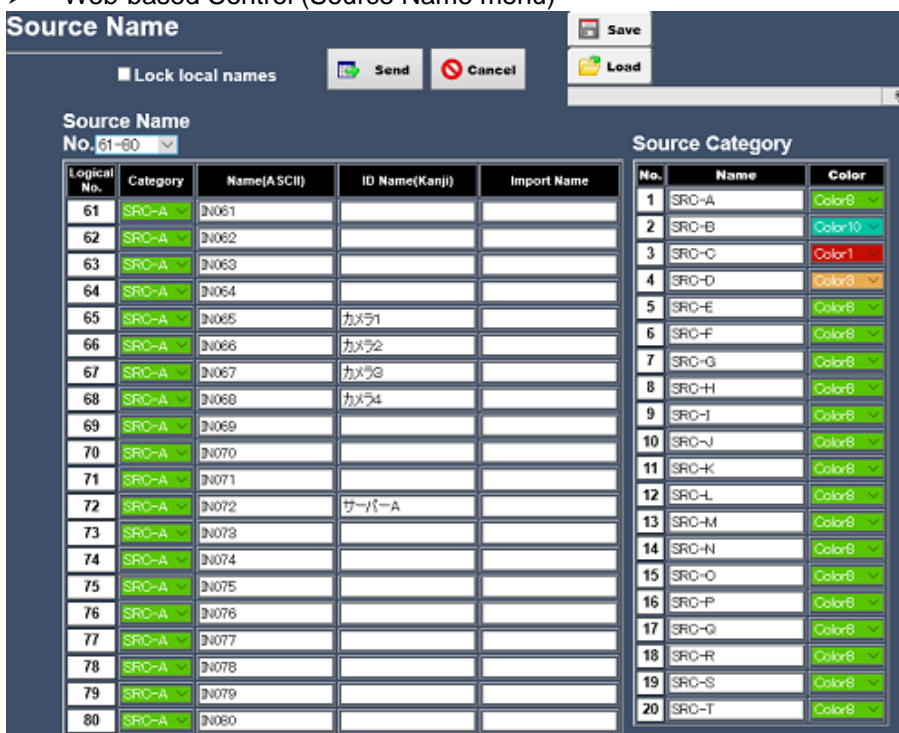

➤ **Terminal display**

Command	@ K?SK,040
---------	------------

Response	@ K?SK,040	Echo
	K:SK040,E382ABE383A1E383A9EFBC91	Kanji Name for Source Channel 65 is カメラ 1 .
	K:SK041,E382ABE383A1E383A9EFBC92	Kanji Name for Source Channel 66 is カメラ 2 .
	K:SK042,E382ABE383A1E383A9EFBC93	Kanji Name for Source Channel 67 is カメラ 3 .
	K:SK043,E382ABE383A1E383A9EFBC94	Kanji Name for Source Channel 68 is カメラ 4 .
	K:SK044,	Kanji Name for Source Channel 69 is empty.
	K:SK045,	Kanji Name for Source Channel 70 is empty.
	K:SK046,	Kanji Name for Source Channel 71 is empty.
	K:SK047,E382B5E383BCE38390E383BCEFBFA1	Kanji Name for Source Channel 72 is サーバー A .
	K:SK05F,	Kanji Name for Source Channel 96 is empty.
	>	Prompt

➤ Response details

K:	S	K	040,	E382AB	E383A1	E383A9	EFBC91
	Source	Kanji	Channel 65	カ	メ	ウ	1

K:	S	K	044,	
	Source	Kanji	Channel 69	(Empty)

K:	S	K	047,	E382B5	E383BC	E38390	E383BC	EFBCA1
	Source	Kanji	Channel 72	サ	—	バ	—	A

5-3-4. CPU Status Request Command (8)

This command allows you to indicate which CPU is active in the MFR-6100.

◆ **Command format**

Command	Command response
@[sp]A?	A:<ID>

BYTE No.	1	2	3	4	5
Command	@	[sp]	A	?	CR

BYTE No.	1	2	3-4	
Response	A	:	<ID>	<ID>: Unit ID number (01-FE)

◆ **Command Response**

Two response types indicate whether the CPU is active or passive state.

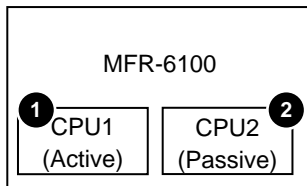

If the CPU is active:

Response	@ A?	Echo
	A:A	Unit ID number is 10 (0x0A)
		New line
	>	Prompt

If the CPU is passive:

Response		No echo, response or prompt
----------	--	-----------------------------

5-3-5. Destination Lock Status Request Command (9)

This command (W?) allows you to indicate destination lock status in the MFR system.

◆ Command format

Control command	Command response
@[sp]W?<Lvl>,<Dest>	W!<Lvl><Dest>,<ID>,0-2

Control command

BYTE No.	1	2	3	4	5	6	7	8
Command	@	[sp]	W	?	<Lvl>	,	<Dest>	CR

<Dest>: Destination channel number

Command response

BYTE No.	1	2	3	4	5	6	7	8	9	10	11	12
Response	CR	LF	W	!	<Lvl>	<Dest>	,	<ID>	,	0	CR	LF
										1		
										2		

*0: Nothing locked

1: LOCK ALL

2: LOCK OTHER

◆ Command Response Examples

If Destination 1 is locked by ID10 Unit using LOCK, Destination 1 status returns as shown below:

Response	@ W?0,0	Echo
	W!00,A,1	Dest 1 is locked by ID10 (0x0A) unit using LOCK ALL.
		CR LF
	>	Prompt

If Destination 2 is locked by ID11 Unit using LOCK OTHER, Destination 2 status returns as shown below:

Response	@ W?0,1	Echo
	W!01,B,2	Dest 2 is locked by ID11 (0x0B) unit using LOCK OTHER.
		CR LF
	>	Prompt

If Destination 3 is not locked, Destination 3 status returns as shown below:

Response	@ W?0,2	Echo
	W!02,0,0	Dest 3 is not locked.
		CR LF
	>	Prompt

5-3-6. Channel Name Import Commands (10)

K: commands allow you to import Source and Destination names from the device that sends K: commands to the MFR system.

◆ Command Format

Command	Command response
K:<S or D><S or L or A><No.>,<Dat>	Echo Prompt

BYTE No.	1	2	3	4	5-7	8	9-	
Command	K	:	S	S	000-3FF	,		CR
			D	L	000-1FF			
				A				

BYTE 3	<S or D> Select between S (Source) or D (Destination)
BYTE 4	<S or L or A > Select the destination to which names are imported. S: Source Name or Destination Name, ID Name (Kanji) fields on the WebGUI. L: Source Name or Destination Name, Import Name fields on the WebGUI. A: Source Name or Destination Name, Name (ASCII) fields on the WebGUI.
BYTE 5-7	<No.> Indicates the channel number. Source: 000-3FF, Destination: 000-1FF
BYTE 9-	<Dat> Indicates the channel names Strings in Hex characters (max. 128 bytes). Character code: UTF-8
CR	Carriage return

5-3-7. Video Format Commands (11)

Video Format Commands allow you to change router video format. The commands can also change reference and switching point settings.

◆ Command Format

	Command description	Command	Command response
(1)	Sets video format, reference and/or switching point beforehand.	@ [sp]UF:<YY>/<R#>,<S\$> *1	UF!<YY>/<R#>,<S\$>
(2)	Performs the set changes.	@ [sp]UE:A	UR!W *2 UR!<YY>/<R#>,<S\$> UR! (error response)
(3)	Cancels the set changes.	@ [sp]UE:C	UR!C

*1 Reference and Switching points are non-compulsory. When they are not input, present settings are output for command response.

*2 "UR!W" is output at 5-seconds intervals after receiving "@ [sp]UE:A." When execution environment is ready, "UR!<YY>/<R#>,<S\$>" is output.

BYTE	1	2	3	4	5	6	7	8	9	10	11	12	13	14
(1)	@	[sp]	U	F	:	<YY>	/		<R#>	,		<S\$>		CR
(2)	@	[sp]	U	E	:	A	CR							
(3)	@	[sp]	U	E	:	C	CR							

<YY>	Video format	00: 1080/59.94i 01: 1080/59.94p 02: 1080/60i 03: 1080/60p 04: 1080/50i 05: 1080/50p 06: 720/60p	07: 720/59.94p 08: 720/50p 09: 1080/30p 0A: 1080/29.97p 0B: 1080/25p 0C: 1080/24p 0D: 1080/23.98p	0E: 1080/30PsF 0F: 1080/29.97PsF 10: 1080/25PsF 11: 1080/24PsF 12: 1080/23.98PsF 13: 525/59.94i 14: 625/50i
<R#>	Reference	RA: Auto	RB: B.B	RT: Tri-Sync
<S\$>	Switching point	SF: Field	SO: Odd	SE: Even

* Commands are not executed if no video format is set or the current video format is set.

◆ **Command Example 1**

Changes Video Format to **720/59.94p**.

Command	Command response
@ [sp]UF:07[CR]	[CR][LF]UF!07/RA,SF[CR]
@ [sp]UE:A[CR]	[CR][LF]UR!W [CR][LF]UR!07/RA,SF[CR]

◆ **Command Example 2**

Changes Video Format to **1080/59.94p**, Reference to **Tri-level Sync** and Switching Point to **Field**.

Command	Command response
@ [sp]UF:01/RT,SF[CR]	[CR][LF]UF!01/RT,SF[CR]
@ [sp]UE:A[CR]	[CR][LF]UR!W [CR][LF]UR!01/RT,SF[CR]

5-3-8. CPU Change-over Commands (12)

CPU Change-over (CPU Swap) commands allow you to swap the active CPU. Available only when CPU2 is passive.

Switches the active CPU from CPU1 to CPU2.

This command should be sent to CPU2.

◆ Command Format

	Command description	Command	Command response
(1)	Sets CPU Swap settings.	@[sp]FC:P	FC!P
(2)	Performs the set changes.	@[sp]FE:A	FR!W
			FR!E (error response)
(3)	Cancels the set changes.	@[sp]FE:C	FR!C

Command

BYTE	1	2	3	4	5	6	7
(1)	@	[sp]	F	C	:	P	CR
(2)	@	[sp]	F	E	:	A	CR
(3)	@	[sp]	F	E	:	C	CR

Command response

BYTE	1	2	3	4	5	6	7
(1)	[CR]	[LF]	F	C	!	P	CR
(2)	[CR]	[LF]	F	R	!	W	CR
	[CR]	[LF]	F	R	!	E	CR
(3)	[CR]	[LF]	F	R	!	C	CR

6. Troubleshooting

If any of the following problems occur while operating your MFR-6100, proceed as indicated below to see if the problem can be corrected before assuming a unit malfunction has occurred.

IMPORTANT

If the problem cannot be corrected by performing the procedures below, turn the unit off and then on again. If doing so still does not correct the problem, contact your dealer.

Problem	Check	Remedy
No image output.	Are there signal inputs to the video input connectors?	Input video signals to the video input connectors.
	Are cables properly connected for the signal inputs?	Properly connect cables.
	Are I/O cards installed into correct slots?	Re-install the I/O cards into their correct slots.
	Are the crosspoints set properly?	Set crosspoints properly.
	Does the I/O card power status show normal? (See Sec. 4-1-4.)	If it is not normal, restart the I/O card. (See Sec. 4-2-2.)
	Does the power status of MATRIX1 and 2 show normal? (See Sec. 4-1-5.)	If it is not normal, restart the MFR-6100.
Unable to control using the remote control panel.	Is the LAN cable properly connected?	Properly connect the LAN cable.
	Does the RU Info page in the Web-based Control indicate NG?	Check the item/s that is indicated as NG. However, if the Voltage is indicated as NG, contact your FOR-A agent. See the Web-based Control User Manual for details.
The secondary CPU is active.	Are both MFR-LAN (CPU1) and MFR-LAN (CPU2) properly connected to the network? (Check the cable and network switch connections.)	Ensure both MFR-LAN (CPU1) and MFR-LAN (CPU2) are connected properly to the network.
	If network connections are properly made, turn the MFR-6100 power OFF then ON again.	Consult your FOR-A agent if the secondary CPU is still active after restarting.
ERROR is indicated on PS1 AC or PS2 AC in [STATUS > POWER] menu.	Is AC100-240V±10% supplied?	Supply AC100-240V±10%.
	Check power supply cord rated current and voltage are as below. 15A 125V (at AC100-120V) 10A 250V (at AC220-240V)	Use the supplied AC cord or other power supply cable over the ratings specified on the left column.

7. Specifications and Dimensions

7-1. Unit Specifications

7-1-1. MFR-6100

Basic specifications

Temperature / Humidity	0°C to 40°C / 30% to 85% (no condensation)
Power	100 VAC to 240 VAC ±10%, 50/60Hz IN
Consumption	SDI 144 x 144, Dual CPU/Redundant Power Unit (Maximum Configuration) 100 V AC to 120 V AC: 1500 VA (1500 W) 220 V AC to 240 V AC: 1584 VA (1457 W)
Dimensions	430 (W) x 576 (H) x 400 (D) mm, EIA 13 RU 480 (W) (Including rack mount brackets)
Weight	88.8 kg (Including all options)
Consumables	Power supply unit: Replace every 5 years FAN1-4 (P-1649): Replace every 4 years. FAN5-6 (P-1648): Replace every 4 years.

Technical specifications

Video Formats	
UHD 4K (12G-SDI)	2160/59.94p, 50p (SMPTE ST 2082-1)
(6G-SDI)	2160/30p, 29.97p, 25p, 24p, 23.98p (SMPTE ST 2081-1)
HD (3G-SDI)	1080/60p, 59.94p, 50p (SMPTE424M)
HD (HD-SDI)	1080/60i, 59.94i, 50i, 30p, 30PsF, 29.97p, 29.97PsF, 23.98p, 23.98PsF, 25p, 25PsF, 24PsF, 24p, 720/60p, 59.94p, 50p (SMPTE292M)
SD (SD-SDI)	525/59.94i, 625/50i (SMPTE259M)
Matrix Size	Min. 9 x 9 to Max. 144 x 144 (Expandable on a 9-channel basis) Number of input slots: 16 Number of output slots: 16
Video Input	
MFR-9SDI12GA	12G/6G/3G/HD/SD-SDI Input Card (16 cards Max.) 75-ohm BNC x 9
MFR-9SDI	6G/3G/HD/SD-SDI Input Card (16 cards Max.) 75-ohm BNC x 9
Video Output	
MFR-9SDO12GA	12G/6G/3G/HD/SD-SDI Output Card (16 cards Max.) 75-ohm BNC x 9 (Auto reclocking)
MFR-9SDO	6G/3G/HD/SD-SDI Output Card (16 cards Max.) 75-ohm BNC x 9 (Auto reclocking)

Process Delay	<p>When MFR-9SDI12GA and MFR-9SDO12GA cards are installed.</p> <p>12G-SDI: Less than 1.0 μs 6G-SDI: Less than 1.0 μs 3G-SDI: Less than 1.0 μs HD-SDI: Less than 1.5 μs SD-SDI: Less than 3.0 μs</p> <p>When MFR-9SDI and MFR-9SDO12GA cards are installed. When MFR-9SDI12GA and MFR-9SDO cards are installed.</p> <p>6G-SDI: Less than 0.5 μs 3G-SDI: Less than 0.5 μs HD-SDI: Less than 0.8 μs SD-SDI: Less than 1.5 μs</p>
Reference Input	BB: 0.429 Vp-p (NTSC) / 0.45 Vp-p (PAL) or Tri-level Sync: 0.6 Vp-p 75-ohm BNC x 2, loop-through (Terminate with 75-ohm terminator, it unused.)
Interfaces	
MFR-LAN	10/100 BASE-TX, RJ-45 x 2 (For connecting up to 128 RU/GPI units.) (Second LAN port used in redundant CPU configuration)
PC-LAN	10/100/1000 BASE-T, RJ-45 x 2 (for PC operation) (Second LAN port used in redundant CPU configuration)
SERIAL	RS-232C/RS-422 (Selectable), 9-pin D-sub (male) x 1
ALARM	9-pin D-sub 9 (female) x1 (Output: Power, Fan Alarm, Crosspoint Error, CPU changeover, Secondary CPU Error, MTX Alarm)

7-1-2. MFR-GPI

Basic specifications

Temperature / Humidity	0°C to 40°C / 30% to 85% (no condensation)
Power	+12VDC pin connector x 2 (redundant power supply as standard)
Consumption	100 V AC to 120 V AC: 8 VA (4 W), 220 V AC to 240 V AC: 13 VA (6 W)
Dimensions	430(W) x 44(H) x 110(D) mm EIA1RU 480 (W) (Including rack mount brackets)
Weight	2 kg
Consumables	AC adaptor: Replace every 5 years

Technical specifications

Number of Connection	Max. 4 (MFR-GPI units only) Max. 128 (including Main, MFR-RU Series, MFR-GPI and MFR-TALM units)
Interface	
MFR-LAN	10/100BASE-TX RJ-45 x 1 (Network switch is needed for Main and multiple unit connections.)
SERVICE	RS-232C: 9-pin D-sub (male) x 1 (for maintenance)
GPI IN/TALLY OUT	37-pin D-sub (female) x 4 128-input/output (user assignable)
SERIAL 1-4	RS-232C/422 (selectable): 9-pin D-sub (male) x 4

7-1-3. MFR-TALM

Basic specifications

Temperature / Humidity	0°C to 40°C / 30% to 85% (no condensation)
Power	+12VDC pin connector x 2 (redundant power supply as standard)
Consumption	100 V AC to 120 V AC: 17 VA (9 W), 220 V AC to 240 V AC: 20 VA (9 W)
Dimensions	212(W) x 44(H) x 161(D) mm EIA 1 RU Half Rack 480 (W) (Including single or dual rack mount brackets)
Weight	2 kg
Consumables	AC adaptor: Replace every 5 years

Technical specifications

Number of Connections	Max. 1 (an MFR-TALM unit only) Max. 128 (including Main, MFR-RU Series, MFR-GPI and MFR-TALM units)
Interface	
MFR-LAN	10/100/1000BASE-T RJ-45 x 1 (Network switch is required for Main and multiple unit connections.)
PC-LAN	10/100BASE-TX RJ-45 x 1 (for PC or other external devices)
GPI IN/TALLY OUT	37-pin D-sub (female) x 1 32-input/output (user assignable)
RS-422	9-pin D-sub (male) x 4

7-2. External Dimensions

7-2-1. MFR-6100

(All dimensions in mm.)

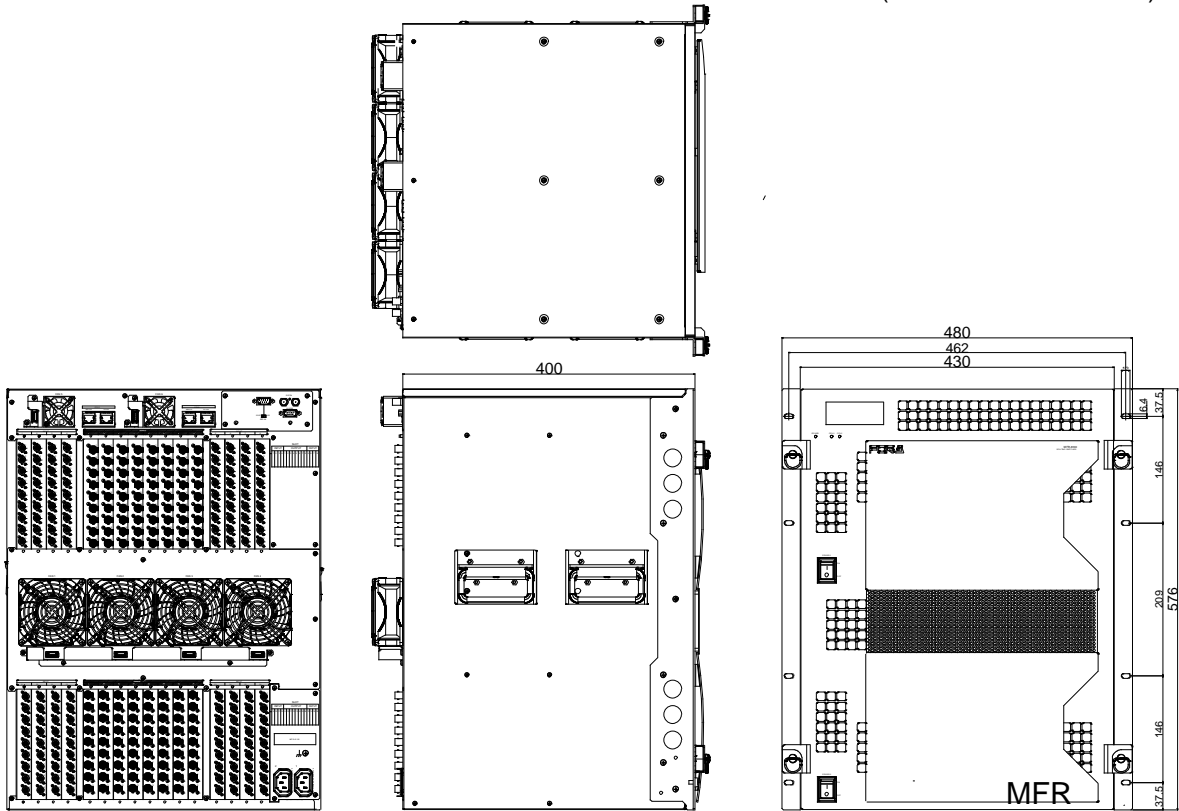

7-2-2. MFR-GPI

(All dimensions in mm.)

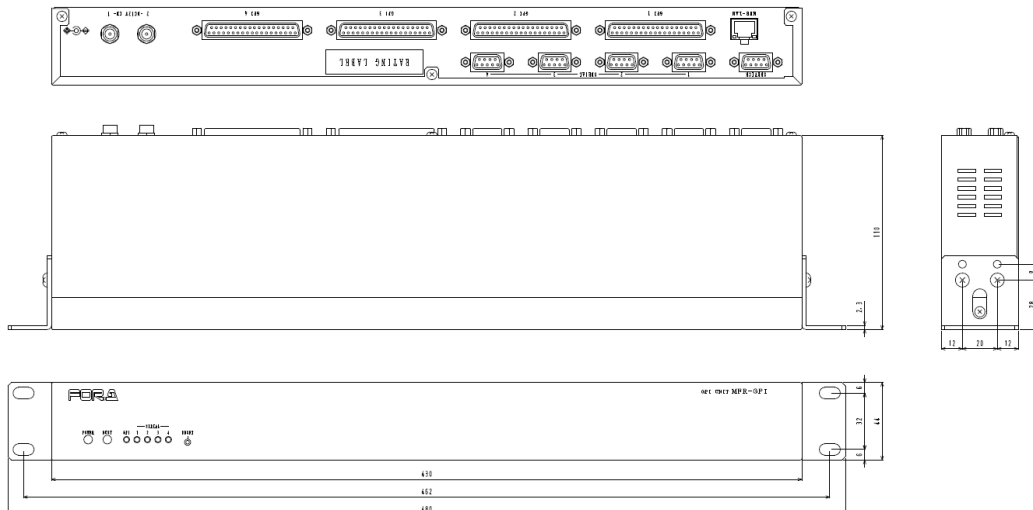

7-2-3. MFR-TALM

(All dimensions in mm.)

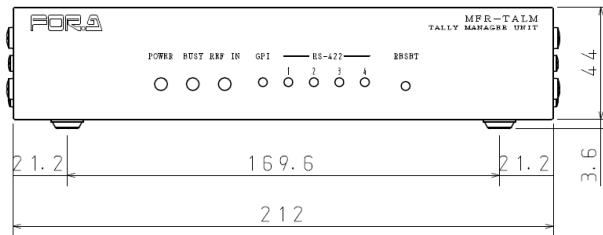
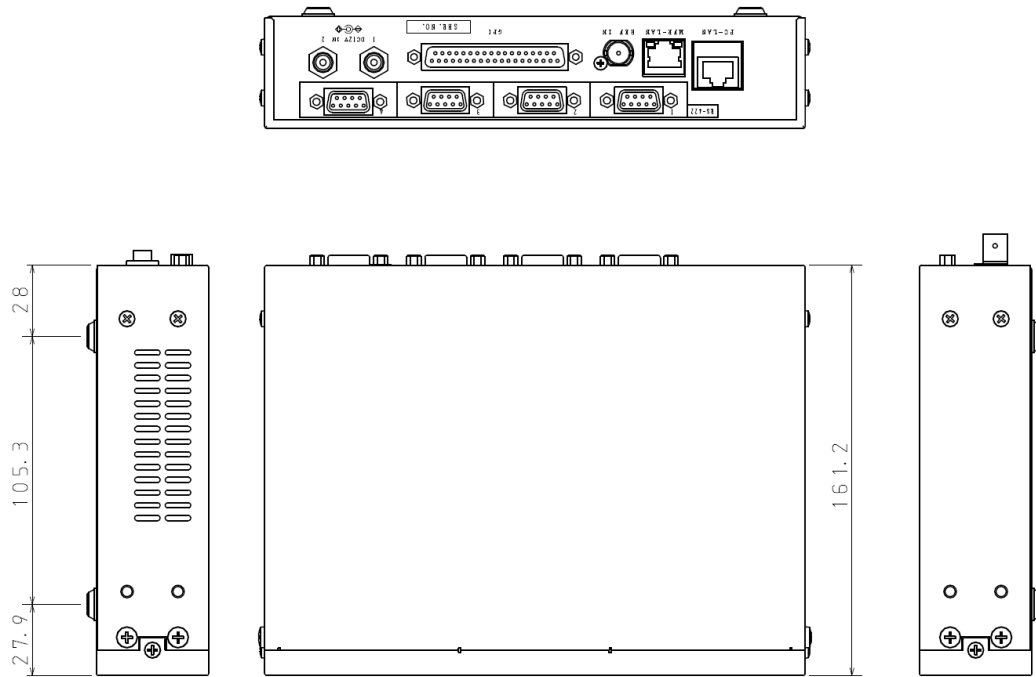

◆ If attaching the rack mount brackets (Dual / Single)

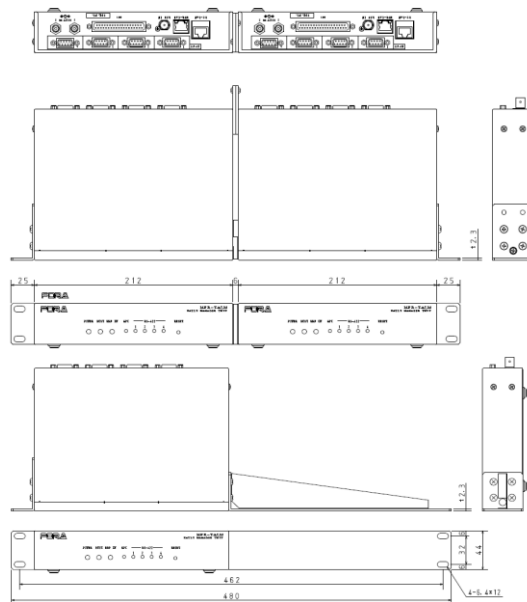

Warning

This equipment has been tested and found to comply with the limits for a Class A digital device, pursuant to Part 15 of FCC Rules. These limits are designed to provide reasonable protection against harmful interference when the equipment is operated in a commercial environment. This equipment generates, uses, and can radiate radio frequency energy and, if not installed and used in accordance with the instruction manual, may cause harmful interference to radio communications. Operation of this equipment in a residential area is likely to cause harmful interference, in which case the user will be required to correct the interference at his own expense.



FOR-A COMPANY LIMITED

Head Office 3-8-1 Ebisu, Shibuya-ku, Tokyo 150-0013, Japan
Overseas Division Tel: +81(0)3-3446-3936 Fax: +81(0)3-3445-5116

FOR-A Corporation of America Corporate Office/Service Center

11155 Knott Ave., Suite G, H & I, Cypress, CA 90630, U.S.A.
Tel: +1 714-894-3311 Fax: +1 714-894-5399

FOR-A Corporation of America Northeast Office

1360 Clifton Ave., Clifton, NJ 07012, U.S.A.
Tel: +1 973-220-8471 Fax: +1 714-894-5399

FOR-A Corporation of America Southeast Office

Tel: +1-305-773-7608

FOR-A Corporation of America Support Center

2400 N.E. Waldo Road, Gainesville, FL 32609, U.S.A.
Tel: +1 352-371-1505 Fax: +1 714-894-5399

FOR-A Latin America and the Caribbean Miami Office

Tel: +1 657-600-5759

FOR-A Latin America and the Caribbean Sao Paulo Office

Tel: +55 (0)11-99913-3751

FOR-A Europe S.r.l.

Via Volturmo, 37, 20861, Brugherio MB, Italy
Tel: +39 (0)39-916-4811

FOR A UK Limited

Trident Court, 1 Oakcroft Road Chessington, KT9 1BD, U.K.
Tel: +44 (0)20-3044-2935 Fax: +44 (0)20-3044-2936

FOR-A Italia S.r.l.

Via Volturmo, 37, 20861, Brugherio MB, Italy
Tel: +39 (0)39-881-086

FOR-A Corporation of Korea

1007, 57-5, Yangsan-ro, Yeongdeungpo-gu, Seoul 07271, Korea
Tel: +82 (0)2-2637-0761 Fax: +82 (0)2-2637-0760

FOR-A China Limited

1618 Huateng Building, No. 302, 3 District, Jinsong, Chaoyang, Beijing 100021, China
Tel: +86 (0)10-8721-6023 Fax: +86 (0)10-8721-6033

FOR-A Middle East Africa Office

Aurora Tower, Office 1407, Dubai Media City, P.O. Box 502688, Dubai, UAE
Tel: +971 (0)4 551 5830 Fax: +971 (0)4 551 5832

FOR-A India Private Limited. Mumbai Office

2nd Floor, Valecha Chambers, Link Road, Andheri (W), Mumbai 400053, India
Tel: +91-(0)22-2673-3623 Fax: +91-(0)22-2639-3415

FOR-A India Private Limited. Delhi Office

8th floor, World Trade Tower, Sector-16, Noida, Uttar Pradesh 201301, India
Tel: +91-(0)12-0423-8674

FOR-A South East Asia Office

Studio 09, Rm. A1, 3/F., Phase 1, Hang Fung Ind. Bldg., 2G Hok Yuen St., Hung Hom, Hong Kong
Tel: +852 2110-1352

