

## CBT SERIES

Constant Beamwidth Technology™

### Key Features:

- ▶ Patented Constant Beamwidth Technology™ provides true wide-band constant directivity coverage up to the highest frequencies and reduces out-of-coverage lobing.
- ▶ 200 cm (6.6 ft) height extends pattern control to include lower frequencies.
- ▶ Vertical pattern coverage switchable between 30° and 15° for medium or long-throw coverage.
- ▶ Asymmetrical Progressive-Gradient vertical coverage setting directs more sound toward the far area of the listening space, making front to back sound levels more consistent. Progressive-Gradient extent is adjustable.
- ▶ Narrow width of 98.5 mm (3.8 in) fits visually into a wide variety of applications.
- ▶ Dynamic Sonic-Guard™ low-audibility overload protection.
- ▶ Swivel (pan) / tilt wall bracket included
- ▶ Built-in 70V/100V transformers, plus direct capability.

The CBT 200LA-1, with Constant Beamwidth Technology™, represents a breakthrough in pattern control consistency and coverage options, utilizing complex analog delay beam-forming and amplitude tapering to accomplish superior, consistent coverage without the inconsistent vertical beaming, uneven coverage, and out-of-coverage lobing that are typical of both powered and non-powered column speakers.

The CBT 200LA-1 assembly consists of a top and a bottom loudspeaker module that, when bolted together end-to-end during installation, form a 32-driver array that is 200 cm (6.6 feet) tall. The height provides excellent pattern control over a wide bandwidth and superb throw capability. The combination of sound quality, pattern control, and compact design makes CBT 200LA-1 ideal for a wide variety of venues, including highly reverberant facilities and those requiring especially long throw or pattern control down to very low frequencies. Venue types include transit centers, conference centers, cathedrals, multipurpose spaces, gymnasiums, and theme parks, among many others.

The slim, compact design fits well into virtually any architectural decor.

### Innovative Coverage Adjustment Capability – Symmetrical Coverage or Asymmetrical Progressive-Gradient Coverage

The CBT 200LA-1 allows the vertical coverage to be switched independently for each of the loudspeaker modules (top and bottom). This allows the system to be set for symmetrically narrow (15 degree) coverage, symmetrical broad (30 degree) coverage, or for asymmetrical progressive-gradient coverage (narrow top module and broad bottom module), which directs higher sound levels toward the far areas of the listening area, leveling out the SPL level differences from front-to-back within the listening space. The proportion of front-to-back differential can also be adjusted by externally lowering the drive level to the bottom loudspeaker module or setting to a lower tap when in 70V/100V operation. This innovative coverage adjustment capability allows a single loudspeaker model to more precisely match the coverage requirements in an extremely wide variety of project types and to accomplish a consistency of coverage that few other loudspeakers can achieve. Horizontal coverage is very wide, at 150° in the mid-range.

### Adjustable Voicing

The voicing can be set to match the needs of the application through a Music/Speech switch. The Music setting provides flat frequency response, while the Speech setting produces a mid-range presence boost to provide clear, intelligible speech even at the longest throw distance. The Speech setting also increases mid-range sensitivity and mid-range Max. SPL capability.

### Components

The thirty-two 50 mm (2 in) drivers each include dual neodymium magnets for light weight, wide bandwidth, high output levels and tighter driver-to-driver spacings, which helps to extend pattern control consistency up to the highest frequencies. Copper capped pole pieces lower both the driver inductance and the flux modulation, resulting in increased high frequency extension and reduced distortion at high drive levels. Butyl rubber surrounds provide long life even in high humidity environments. The drivers cones are weather treated and magnets are shielded. Minimally audible Dynamic SonicGuard™ minimizes distortion at high drive levels by limiting low frequency excursion dynamically. This maximizes clarity at high drive levels while protecting the drivers from damage due to short-term overpowering.

### Coupler Plate and Wall Brackets

The included Coupler Plate contains four M6 threaded points for attaching the included swivel (pan) / tilt wall-mount bracket, plus the back panel of the system includes twenty-eight (28) available M6 inserts on the back panel which can be utilized to suspend the speaker using forged shoulder steel eyebolts, providing installation versatility. Alternatively, for flush-mounting the back of the cabinet to a surface, two optional MTC-CBT-FM1 brackets can be utilized (one on the top and one on the bottom loudspeaker module).

### High Outdoor Capability

CBT 200LA-1 can be installed either indoors or outdoors. The drivers are weather-treated, the fiberglass reinforced ABS cabinet is excellent for outdoor applications, external screws are stainless steel, terminals are outdoor-capable, optional MTC-PC2 terminal panel cover can provide additional terminal protection, the painted aluminum grille resists rusting, and the grille backing breaks up driving rain. With MTC-PC2, the speaker is rated IP-55 per IEC529.

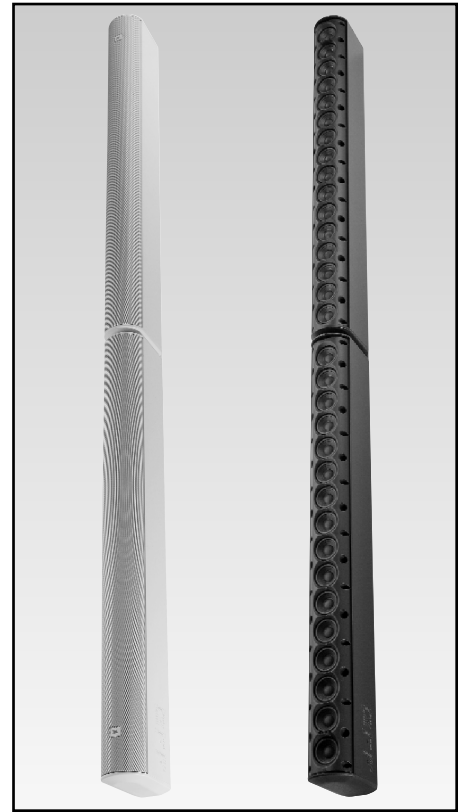

Shown in white with included grille: black with included grille removed.

# ► CBT 200LA-1 Line Array Column with Thirty-Two 50 mm (2 in) Drivers

## Wiring Hookup

It is important to make sure that the two speaker modules (top and bottom) are connected in the same polarity. Connecting the same signal cable in parallel to both speaker modules is recommended.

## System Design Tools

Vertical coverage can be easily modeled using JBL's free CBT Calculator software, downloadable from the [www.JBLPro.com](http://www.JBLPro.com) website. EASE and CLF files for CBT 200LA-1 are posted on-line for modeling coverage using EASE and other modeling programs.

CBT 200LA-1 is available in black or white (-WH).

## Preliminary Specifications:

|                                   |  |   |  |
|-----------------------------------|--|---|--|
| Components:                       | Thirty-two 50 mm (2 in) Full-Range Drivers   |   |  |
| Frequency Range (-10 dB):         | 80 Hz – 20 kHz   |   |  |
| Frequency Response ( $\pm 3$ dB): | 130 Hz – 18 kHz (narrow coverage, music mode setting)  |   |  |
| Coverage:                         | Vertical:<br>Narrow Mode: 15° (500 Hz – 16 kHz, +15°/-2° [ $<60^\circ$ down to 220 Hz, $<90^\circ$ down to 140 Hz])<br>Broad Mode: 30° (400 Hz – 12 kHz, +15°/-8°, [ $<60^\circ$ down to 220 Hz, $<90^\circ$ down to 140 Hz])<br>Asymmetrical Progressive-Gradient Mode: (Top speaker module set at "Narrow" and bottom speaker module at "Broad", for "J-type" coverage, sending higher sound levels toward the far area of the listening space): 22.°(+7° from aiming axis up; -15° from aiming axis down, 300 Hz – 12 kHz, +15°/-8°, [ $<60^\circ$ down to 220 Hz, $<90^\circ$ down to 140 Hz])<br>Horizontal: 150° (ave, 1 kHz – 4 kHz, $\pm 20^\circ$ ) |   |  |
| Sensitivity:                      | Narrow   | (speech mode): 95 dB (2 kHz – 5 kHz)<br>(music mode): 92 dB (150 Hz – 18 kHz)               |  |
|                                   | Broad  | (speech mode): 93 dB (2 kHz – 5 kHz)<br>(music mode): 90 dB (150 Hz – 18 kHz)               |  |
|                                   | Asymmetrical Progressive-Gradient Mode (on-axis):<br>(speech mode): 94 dB (2 kHz – 5 kHz)<br>(music mode): 91 dB (150 Hz – 18 kHz)   |   |  |
| Nominal Impedance (direct):       | 8 $\Omega$ per half (top and bottom) for 4 ohms total (in thru mode). Min-Z for system = 2.9 $\Omega$ .  |   |  |
| Hookup:                           | Ensure identical polarity of hookup – for proper functioning, the two loudspeaker modules (top and bottom) must be hooked up in same polarity. Parallel hookup at the two sets of back panel input terminals is recommended.   |   |  |
| Power Capacity (thru setting):    | 650W (2600W peak), 2 hrs<br>400W (1600W peak) 100 hrs  |   |  |
| Max SPL <sup>1</sup> :            | Narrow   | (speech mode): 123 dB cont ave (129 dB peak)<br>(music mode): 120 dB cont ave (126 dB peak) |  |
|                                   | Broad  | (speech mode): 121 dB cont ave (127 dB peak)<br>(music mode): 118 dB cont ave (124 dB peak) |  |
|                                   | Asymmetrical Progressive-Gradient Mode (on-axis):<br>(speech mode): 122 dB cont ave (128 dB peak)<br>(music mode): 119 dB cont ave (125 dB peak)   |   |  |
| 70V/100V Transformer Type:        | Set individually per speaker module (top and bottom): 120W, 60W, 30W (15W at 70V only), and direct 8 $\Omega$ , via switch. Total (with top & bottom set to same): 240W, 120W, 60W (30W at 70V only) and direct 4 $\Omega$ . Max. insertion loss less than 1 dB at any tap.  |   |  |
| Enclosure:                        | Fiberglass reinforced ABS cabinet, painted aluminum grille   |   |  |
| Connectors:                       | Two (one for top half and one for bottom half), screw-down terminal strip, zinc-plated copper base, nickel plated metal screws/washers. Accepts up to 9 mm outside 4 mm inside open lug (#6, #8 or #10 lug), or bare wire (up to 12 AWC/2.5 mm <sup>2</sup> )  |   |  |
| Outdoor Capability:               | IP-55 rated, per IEC529, when installed with optional MTC-PC2 panel cover. UV, moisture and 200-hr salt-spray resistant.   |   |  |
| Colors:                           | Black or White (-WH)   |   |  |
| Configuration:                    | Two pieces (top and bottom half), each 100 cm tall, connected together via Coupler Plate. Top/bottom orientation of each piece must be observed.   |   |  |
| Insert Points:                    | 28 M6 insert points on back panel (36 total with 8 center points being utilized by the Coupler Plate).   |   |  |
| Mounting:                         | Included swivel (pan) / tilt wall bracket (must be mounted to threaded points on Coupler Plate) provides continuously variable $\pm 80^\circ$ left-right swivel aiming (at up to $\pm 5^\circ$ up/down tilt), continuously adjustable $\pm 10^\circ$ up/down tilt, as well as 5° fixed increment tilt angles to $\pm 10^\circ$ . Twenty-eight available threaded mounting points (M6 diameter x M1 thread pitch x 17 mm deep) located on back panel. Threaded mounting points can be utilized for suspension. Compatible with OmniMount 30.0 brackets  |   |  |
| Dimensions (H x W x D):           | 2000 x 98.5 x 153 mm (78.8 x 3.8 x 6.0 in)   |   |  |
| Net Weight:                       | 14.6 kg (33 lb)  |   |  |
| Included Accessories:             | Swivel (pan) / tilt wall bracket, Coupler plate  |   |  |
| Optional Accessories:             | MTC-PC2 terminal panel cover<br>MTC-CBT-FM1 flush-mount low-profile wall-mount bracket (2 pieces required)<br>MTC-CBT-SMB1 stand-mount bracket for use with 35 mm speaker stands (heavy duty stand required)   |   |  |

<sup>1</sup> Full-space.

<sup>2</sup> IEC standard, full bandwidth pink noise with 6 dB crest factor.

<sup>3</sup> Continuous pink noise, average power with peaks 6 dB higher than this figure. Calculated based on power rating and measured sensitivity, exclusive of power compression.

# Broad Setting

## Frequency Response:

“Music” Mode (solid); “Speech” Mode (dotted), 1W, 1m, and Impedance

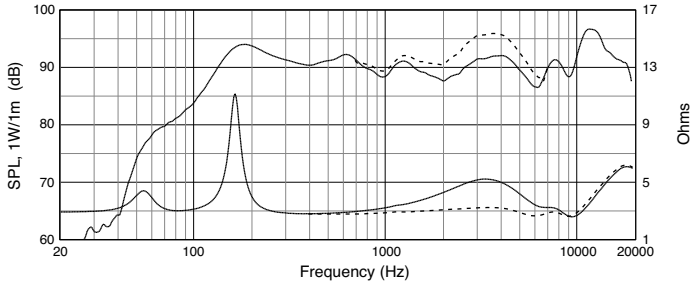

# Narrow Setting

## Frequency Response:

“Music” Mode (solid); “Speech” Mode (dotted), 1W, 1m, and Impedance

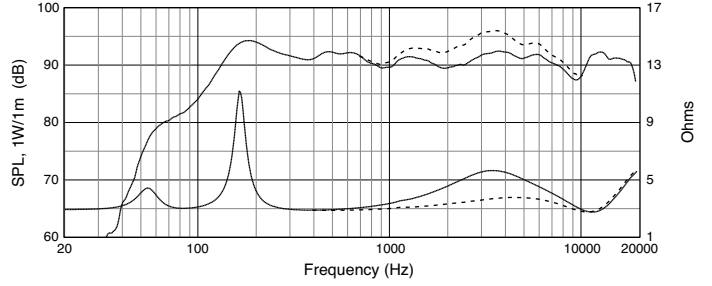

## Beamwidth:

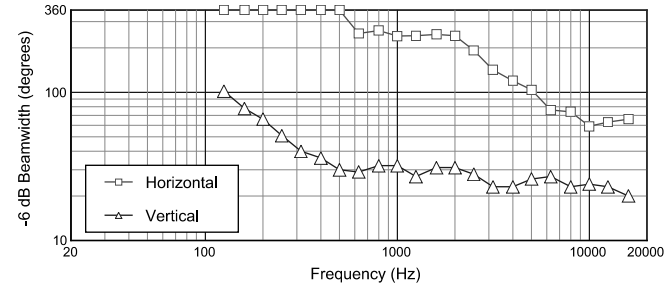

## Beamwidth:

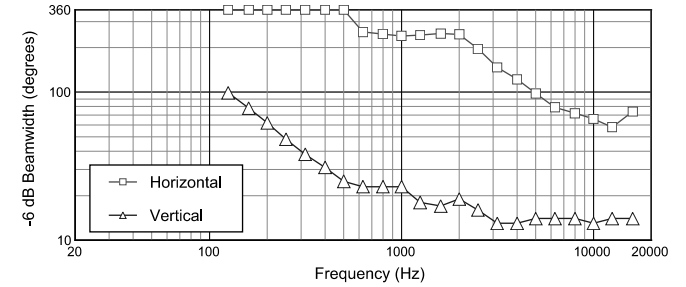

## Directivity, Q

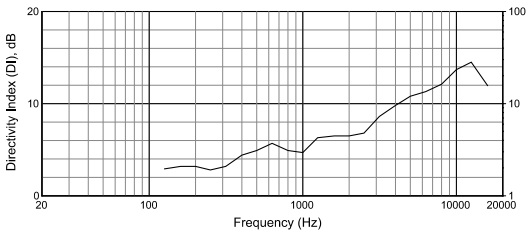

## Directivity, Q

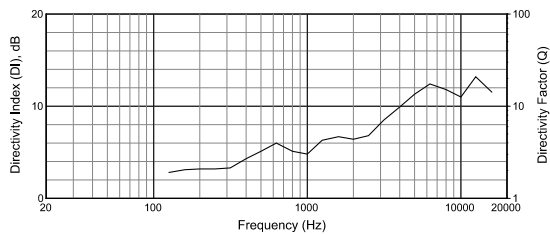

## Vertical Off-Axis Frequency Response

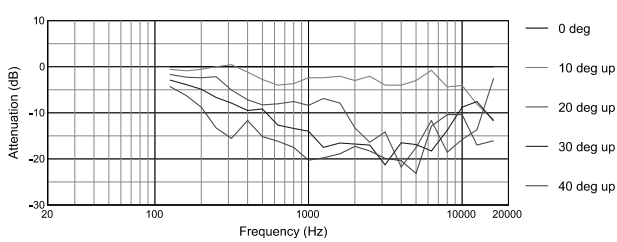

## Vertical Off-Axis Frequency Response

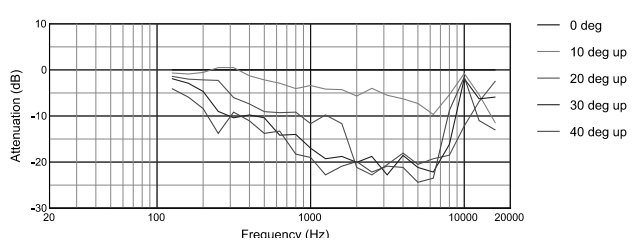

## Horizontal Off-Axis Frequency Response

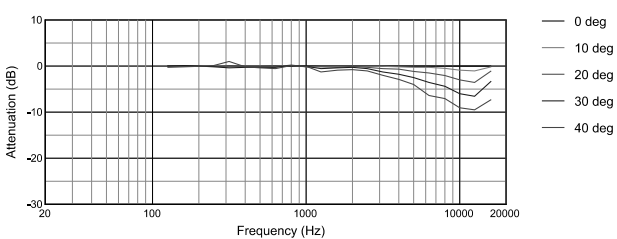

## Horizontal Off-Axis Frequency Response

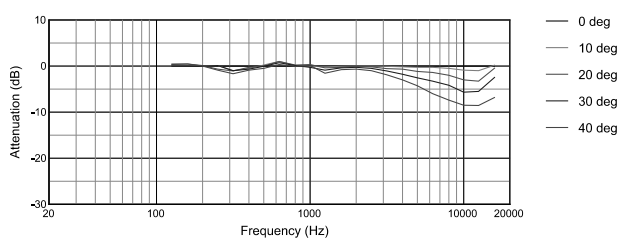

# ► CBT 200LA-1 Line Array Column with Thirty-Two 50 mm (2 in) Drivers

## Asymmetrical Progressive-Gradient Setting

### Frequency Response:

“Music” Mode (solid); “Speech” Mode (dotted), 1W, 1m, and Impedance

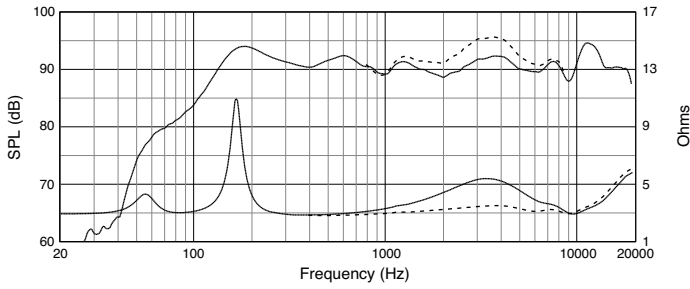

### Beamwidth:

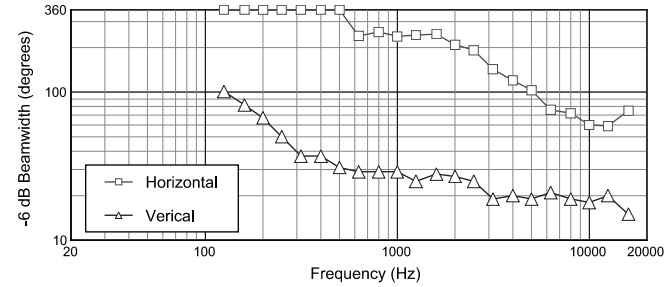

### Directivity, Q

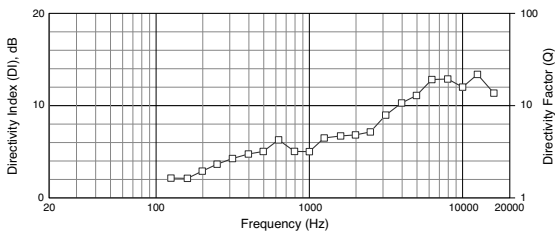

### Vertical Off-Axis Frequency Response

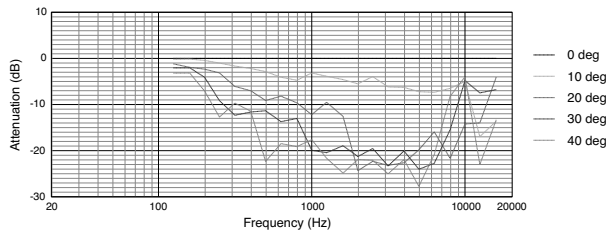

### Horizontal Off-Axis Frequency Response

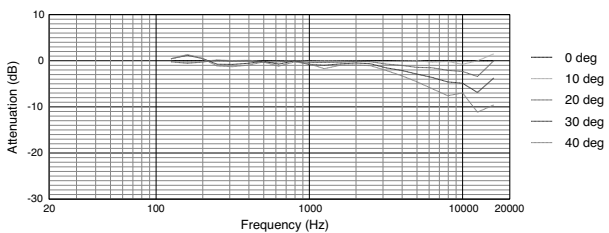

## Horizontal 1/3 Octave Polars

Broad Setting – Typical of Narrow and Asymmetrical Setting

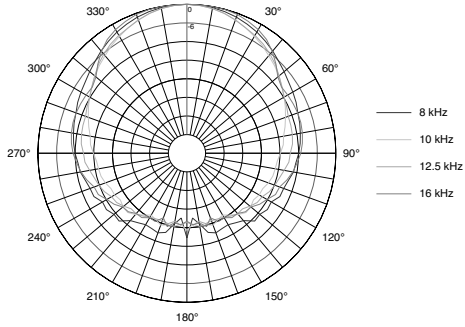
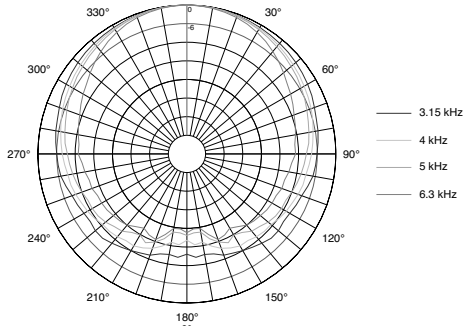
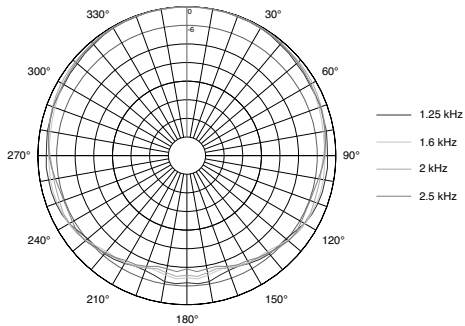
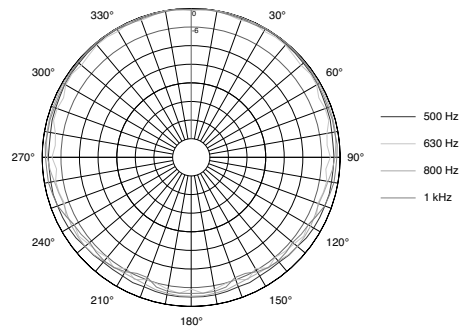
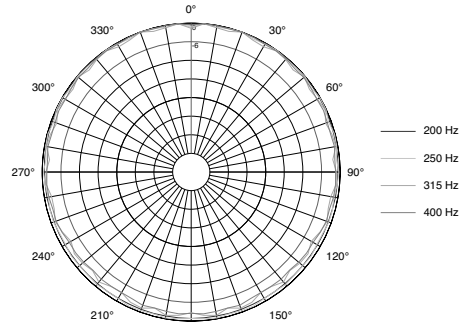

# Vertical 1/3 Octave Polars

## Broad Setting

## Narrow Setting

## Asymmetrical Setting

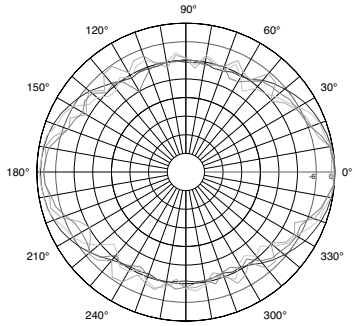

- 200 Hz
- 250 Hz
- 315 Hz
- 400 Hz

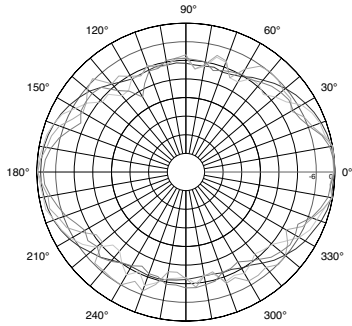

- 200 Hz
- 250 Hz
- 315 Hz
- 400 Hz

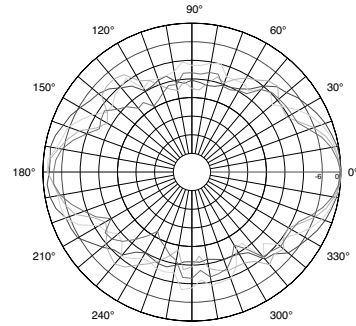

- 200 Hz
- 250 Hz
- 315 Hz
- 400 Hz

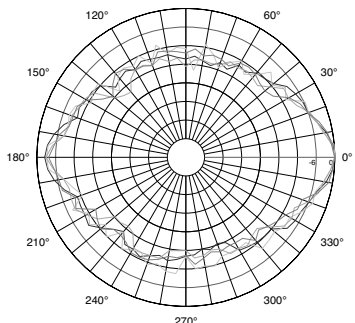

- 500 Hz
- 630 Hz
- 800 Hz
- 1 kHz

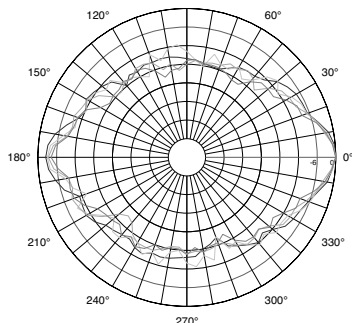

- 500 Hz
- 630 Hz
- 800 Hz
- 1 kHz

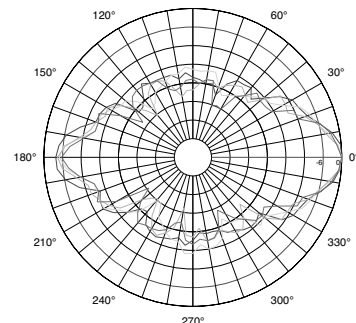

- 500 Hz
- 630 Hz
- 800 Hz
- 1 kHz

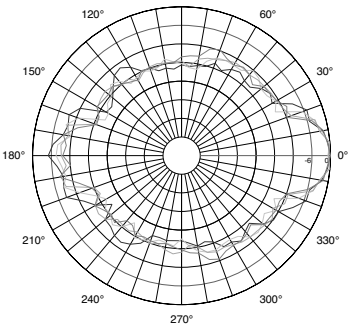

- 1.25 kHz
- 1.6 kHz
- 2 kHz
- 2.5 kHz

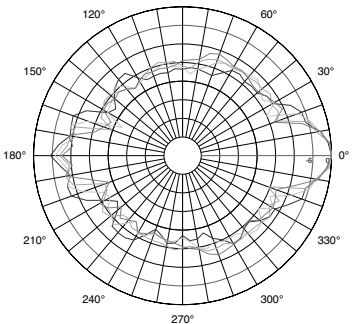

- 1.25 kHz
- 1.6 kHz
- 2 kHz
- 2.5 kHz

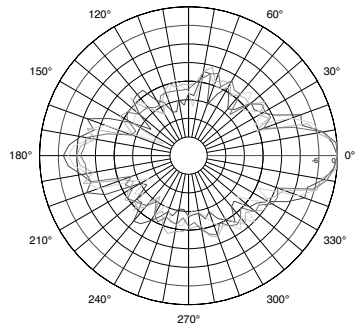

- 1.25 kHz
- 1.6 kHz
- 2 kHz
- 2.5 kHz

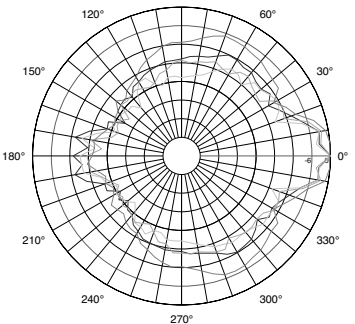

- 3.15 kHz
- 4 kHz
- 5 kHz
- 6.3 kHz

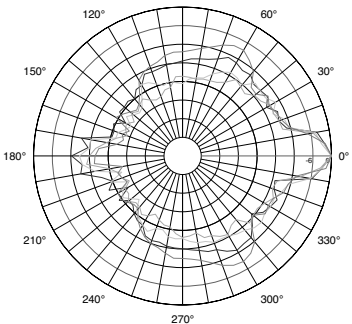

- 3.15 kHz
- 4 kHz
- 5 kHz
- 6.3 kHz

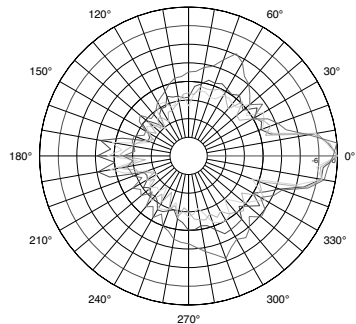

- 3.15 kHz
- 4 kHz
- 5 kHz
- 6.3 kHz

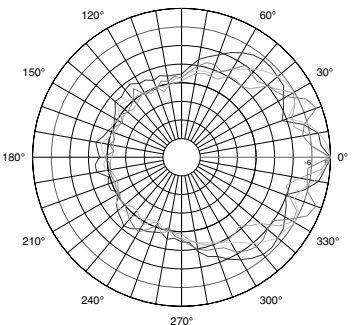

- 8 kHz
- 10 kHz
- 12.5 kHz
- 16 kHz

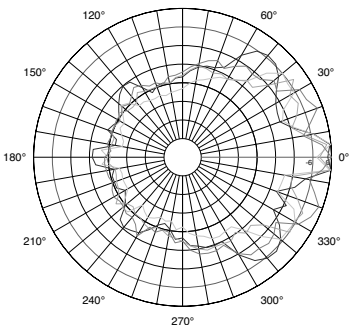

- 8 kHz
- 10 kHz
- 12.5 kHz
- 16 kHz

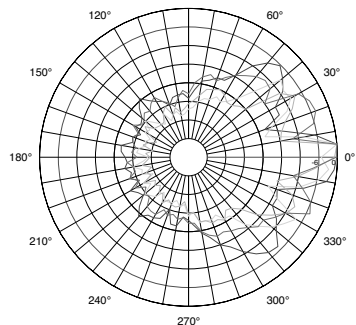

- 8 kHz
- 10 kHz
- 12.5 kHz
- 16 kHz

# ► CBT 200LA-1 Line Array Column with Thirty-Two 50 mm (2 in) Drivers

## Dimensions:

Dimensions in mm (in)

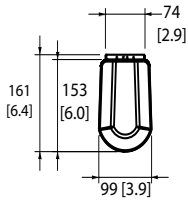

## Bracket:

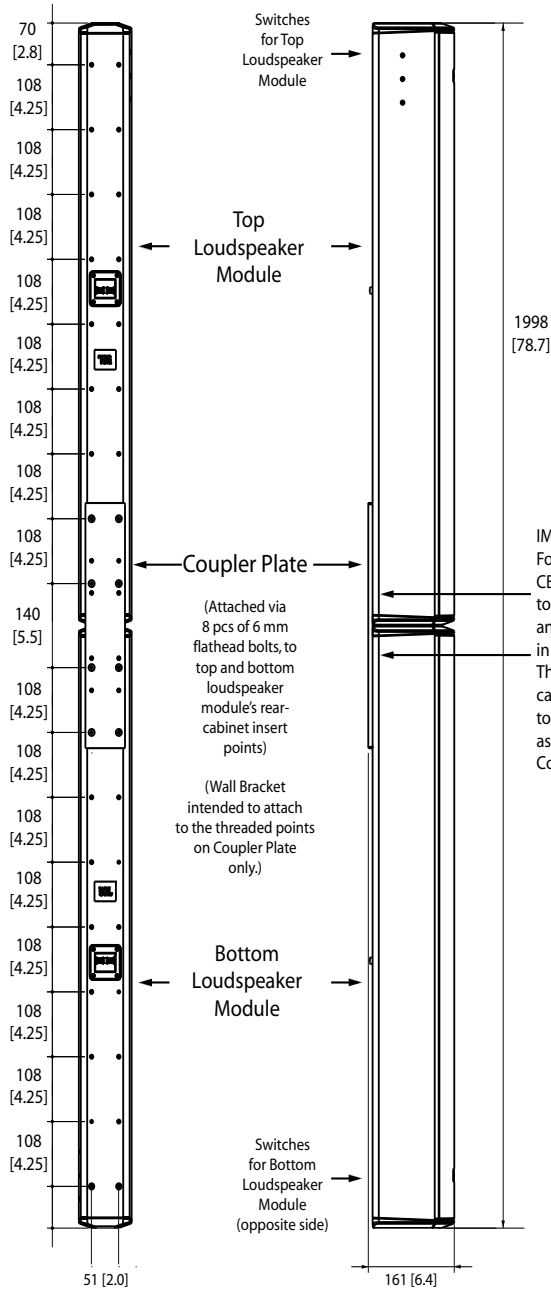
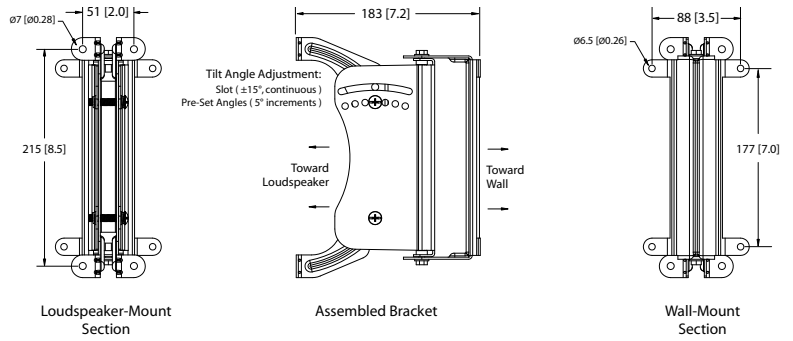

1998 [78.7]

**IMPORTANT:**  
For proper functioning of CBT 200LA-1, it is important to couple together the top and bottom speaker modules in the proper orientation. The arrows printed on the rear cabinet labels must point toward each other during assembly, before attaching Coupler Plate.

## Coupler Plate

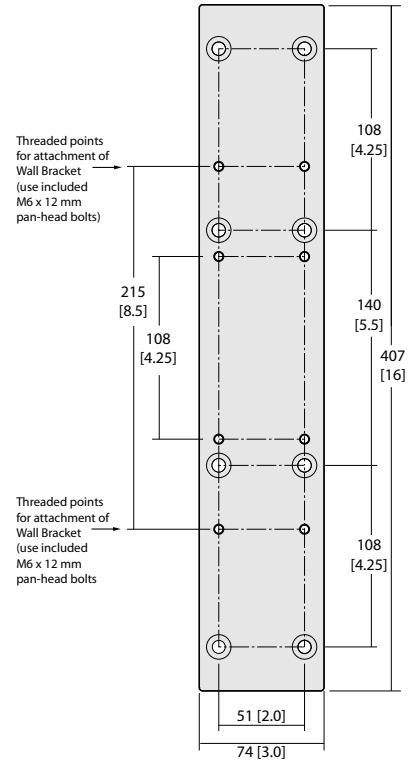

JBL Professional  
8500 Balboa Boulevard, P.O. Box 2200  
Northridge, California 91329 U.S.A.

© Copyright 2012 JBL Professional  
www.jblpro.com

SSCBT 200LA1  
CRP  
07/12