

Before operating the unit, please read this manual thoroughly and retain it for future reference.

WARNING

To reduce the risk of fire or electric shock, do not expose this apparatus to rain or moisture.

To avoid electrical shock, do not open the cabinet. Refer servicing to qualified personnel only.

CAUTION

- Danger of explosion if battery is incorrectly replaced. Replace only with the same or equivalent type recommended by the manufacturer.
- When you dispose of the battery or the product, you must obey the law in the corresponding area or country. Do not dispose of the battery or the product in a fire or a hot oven, or mechanically crush or cut the battery. It may explode or cause a fire. Do not subject the battery to extremely low air pressure that may result in an explosion or the leakage of flammable liquid or gas.
- Do not place the battery in a high temperature place, such as under direct sunlight or near fire. It may ignite, explode, or cause a fire. Do not immerse or wet the battery in water or seawater. This may cause an electric shock.

Do not install the appliance in a confined space, such as book case or built-in cabinet.

WARNING

Batteries shall not be exposed to excessive heat such as sunshine, fire or the like.

IMPORTANT

The nameplate is located on the bottom.

This equipment is not suitable for use in locations where children are likely to be present.

For the customers in the U.S.A.

This equipment has been tested and found to comply with the limits for a Class A digital device, pursuant to part 15 of the FCC Rules. These limits are designed to provide reasonable protection against harmful interference when the equipment is operated in a commercial environment. This equipment generates, uses and can radiate radio frequency energy and, if not installed and used in accordance with the instruction manual, may cause harmful interference to radio communications. Operation of this equipment in a residential area is likely to cause harmful interference in which case the user will be required to correct the interference at his own expense.

You are cautioned that any changes or modifications not expressly approved in this manual could void your authority to operate this equipment.

This device complies with part 15 of the FCC Rules. Operation is subject to the following two conditions: (1) This device may not cause harmful interference, and (2) this device must accept any interference received, including interference that may cause undesired operation.

For the customers in Canada

CAN ICES-3 (A)/NMB-3(A)

For the customers in Europe

This product is intended for use in the following Electromagnetic Environments: E2 (commercial and light industrial), E3 (urban outdoors), E4 (controlled EMC environment, ex. TV studio).

For the customers in Europe, Australia and New Zealand

WARNING

This equipment is compliant with Class A of CISPR 32. In a residential environment this equipment may cause radio interference.

This apparatus shall not be used in the residential area.

경고

화재나 감전 위험을 방지하려면 장치가 물기나 습기에 노출되지 않도록 하십시오.

감전 위험이 있으므로 본체를 열지 마십시오. 자격 있는 전문 정비 요원만 서비스를 실시해야 합니다.

주의

배터리를 잘못 교체하면 폭발 위험이 있습니다.

제조업체에서 권장하는 것과 같거나 상응하는 배터리 타입으로만 교체하십시오. 배터리를 처분할 때에는 반드시 해당 지역 또는 국가의 법률에 따르십시오.

책상이나 불박이 캐비닛 등 막힌 공간 내에 기기를 설치하지 마십시오.

경고

배터리가 직사 광선, 불 등과 같은 과도한 열에 노출되어서는 안됩니다.

A급 기기(업무용 방송통신기자재)
이 기기는 업무용(A급) 전자파적합기로서 판매자 또는 사용자는 이 점을 주의하시기 바라며, 가정외의 지역에서 사용하는 것을 목적으로 합니다.

식별부호: MSIP-REI-SOK-AXS-R7
상호명: 소니코리아㈜
제품명칭: Portable Memory Recorder
모델명: AXS-R7
제조년월: 제품에 표시
제조사/제조국가: Sony Corporation/
Japan

중요

명판은 기기의 다음 위치에 있습니다.
- 아래쪽

Türkiye'deki müşteriler için
AEEE Yönetmeliğine Uygundur

For the customers in the U.S.A.

SONY LIMITED WARRANTY - Please visit <http://www.sony.com/psa/warranty> for important information and complete terms and conditions of Sony's limited warranty applicable to this product.

For the customers in Canada

SONY LIMITED WARRANTY - Please visit <http://www.sonybiz.ca/pro/lang/en/ca/article/resources-warranty> for important information and complete terms and conditions of Sony's limited warranty applicable to this product.

For the customers in Europe

Sony Professional Solutions Europe - Standard Warranty and Exceptions on Standard Warranty.

Please visit https://pro.sony/en_GB/support-services/warranty/support-professional-solutions-europe-standard-product-warranty for important information and complete terms and conditions.

For the customers in Korea

SONY LIMITED WARRANTY - Please visit <http://bpeng.sony.co.kr/handler/BPAS-Start> for important information and complete terms and conditions of Sony's limited warranty applicable to this product.

Usage Precautions

If the unit is suddenly taken from a cold to a warm location, or if ambient temperature suddenly rises, moisture may form on the outer surface of the unit and/or inside of the unit. This is known as condensation. If condensation occurs, turn off the unit and wait until the condensation clears before operating the unit. Operating the unit while condensation is present may damage the unit.

The fan and battery are consumable parts that will need periodic replacement.

When operating at room temperature, a normal replacement cycle will be about 5 years.

However, this replacement cycle represents only a general guideline and does not imply that the life expectancy of these parts is guaranteed. For details on parts replacement, contact your dealer.

The life expectancy of the AC adapter and the electrolytic capacitor is about 5 years under normal operating temperatures and normal usage (8 hours per day; 25 days per month). If usage exceeds the above normal usage frequency, the life expectancy may be reduced correspondingly.

The battery terminal of this unit (the connector for battery packs and AC adaptors) is a consumable part.

Power may not be supplied to the unit properly if the pins of the battery terminal are bent or deformed by shock or vibrations, or if they become corroded due to prolonged outdoor use. Periodic inspections are recommended to keep the unit working properly and to prolong its usable lifetime.

Contact a Sony service or sales representative for more information about inspections.

Features

The AXS-R7 is a portable memory recorder that uses AXS memory cards (A-series only) as the recording media. It features a toggle connector for connection to camcorders, such as the PMW-F5/F55 and MPC-3610 (VENICE/CineAltaV).

It supports recording and playback operations controlled from the connected camcorder.

Notes

- PMW-F5/F55 firmware version 8.0 or later is required for connection with the PMW-F5/F55.
- When used connected with an MPC-3610, the firmware version of the unit must match the MPC-3610 version. For details, refer to the operating instructions for the MPC-3610.

• High frame rate (HFR) function support

– 4K 120 FPS recording

Supports recording in 4K at 120 FPS when connected to a PMW-F55 or MPC-3610. 4K 5× slow recording is supported by recording at a system frequency of 23.98P.

– 6K 90 FPS recording

Supports recording in 6K at 90 FPS when connected to a MPC-3610 (VENICE/CineAltaV). A High Frame Rate license (CBKZ-3610H/3610HM/3610HW) is required for high frame rate shooting. For details, refer to the operating instructions for the MPC-3610 (VENICE/CineAltaV).

Note

Use AXS-A512S48 or AXS-A1T548 memory cards when recording in 4K 120 FPS RAW SQ, 4K 120 FPS X-OCN ST, or 6K 90 FPS X-OCN. For details, refer to the operating instructions for the MPC-3610 (VENICE/CineAltaV).

• Recording in new X-OCN format

In addition to F55RAW recording mode, it also supports recording in the new, more efficient X-OCN recording mode.

• Picture cache function

Supports recording of video and audio data shot before recording is physically started by always caching several seconds (up to 30 seconds) of data in internal memory.

Location and Function of Parts

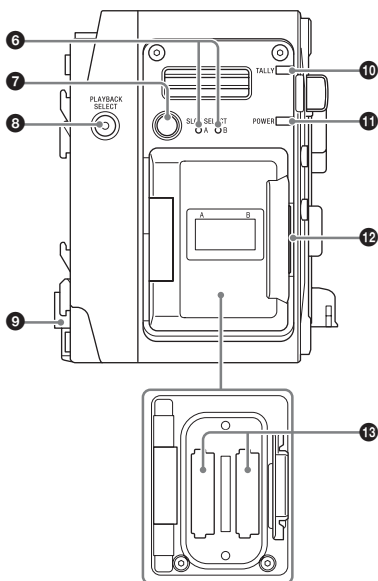
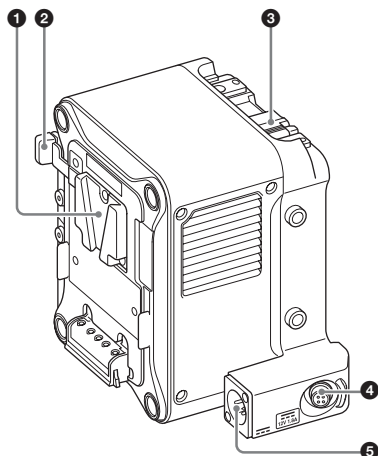

Note

Always disconnect the battery pack and DC IN connector DC supply cable before connecting or disconnecting another device to or from this unit.

Refer to the operating instructions for the connected camcorder when using this unit.

1 Battery pack mount

Supplies power from a battery pack, or from an AC supply via an AC adaptor.

For safety, use only the Sony battery packs and AC adaptors listed below.

Battery pack: BP-FL75/BP-GL95B

AC adaptor: AC-DN10A

Notes

- Before installation, charge the battery pack using a battery charger.
- Charging the battery pack immediately after use when the temperature of the battery pack is high may not fully charge the battery pack.

2 Battery release lever

Press to release the lock, allowing the battery pack to be removed.

3 Release lever

Press the release button to unlock and then lift the lever when attaching the unit to a camcorder and when removing the unit from a camcorder.

4 DC OUT connector (4-pin)

Supplies 12 V DC power to peripheral devices, such as a monitor or LED light. A REC Tally signal output and REC Trigger signal input can also be connected via the DC OUT connector.

4-pin, female



- External View -

No.	Signal	I/O	Specification
1	UNREG GND	-	GND for UNREG
2	REC TALLY	OUT	Open-collector output (Max. 50 mA) Low: REC
3	REC TRIGGER	IN	Open or +5 V DC: Normal GND: Active (REC)
4	UNREG +12 V OUT	OUT	+11 V to 17 V DC output

Note

Connect only devices with current consumption rating of 1.8 A or lower to the DC OUT connector. If an overcurrent condition is detected, output stops. Check the connection with peripheral devices and then turn on the power supply again.

5 DC IN connector

Supplies DC power to the unit using the optional DC power supply cable.

6 Access lamps A/B

Indicates the state of card slots A and B.

Red: Accessing the inserted AXS memory card

Green: Standby state (mounted AXS memory card is ready for playback/recording)

Off: Valid memory card is not inserted

7 SLOT SELECT button

When memory cards are mounted in both card slots A and B, press this button to select the memory card to use.

8 PLAYBACK SELECT button/indicator

The indicator is lit when playback is enabled. When not lit, press the PLAYBACK SELECT button to enable playback.

Playback is controlled from the connected camcorder.

9 Camera mount connector

Connects to a camcorder to deliver both signal and power.

Note

A data transfer error may occur if there is any dust or other matter adhering to the camera mount connector. If the connector is dirty, clean the connector using a cotton swab.

10 TALLY lamp

Lit when recording is in progress.
It flashes when an error or warning condition occurs. The main causes are indicated below. For other causes, refer to the operation manual for the connected camcorder.

Flashing (1 time/sec): Remaining media warning (about 5 minutes)

Flashing (4 times/sec): No remaining media or an error occurred

11 POWER indicator

Lit when power is supplied from the camcorder.

12 Memory slot cover open button

Press to open the cover when inserting/removing an AXS memory card.

13 AXS memory card slots A/B

Insertion slots for AXS memory cards. Insert an AXS memory card all the way into the slot with the AXS logo mark facing the battery.

The following AXS memory cards can be used in the unit.

- AXS-A1TS24 (1 TB/2.4 Gbps)
- AXS-A512S24 (512 GB/2.4 Gbps)
- AXS-A256S24 (256 GB/2.4 Gbps)
- AXS-A1TS48 (1 TB/4.8 Gbps)
- AXS-A512S48 (512 GB/4.8 Gbps)

Using with a Camcorder

This section describes connection with the PMW-F5/F55.

When connecting the unit to the MPC-3610, refer to the operating instructions for the MPC-3610.

Attaching to a Camcorder

Note

Turn off the camcorder before attaching/removing the unit.

- 1 Press the release button on the unit (1) to pop-up the release lever, then raise the release lever till it points up (2).

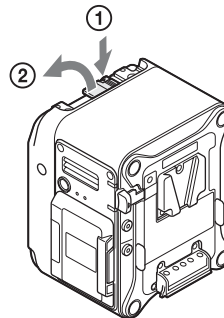

- 2 Insert the tabs on the unit into the grooves on the rear surface of the camcorder (1), and lower the release lever (2).

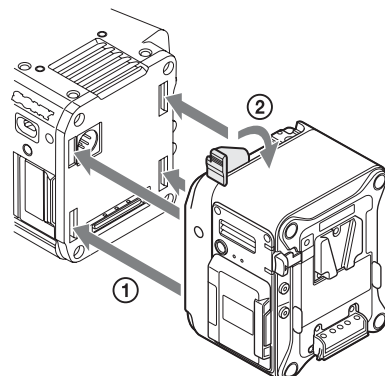

Notes

- Attach the unit after raising the release lever.
- Check that the four tabs are securely engaged before lowering the release lever. If not engaged, the unit may not be attached properly or may damage the camcorder or unit.

- 3** Screw the supplied top plate onto the unit and camcorder (hex key wrench size 3/16").

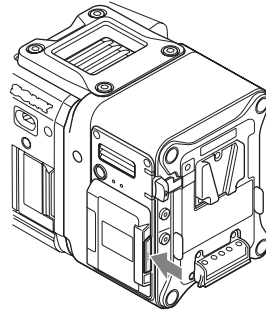
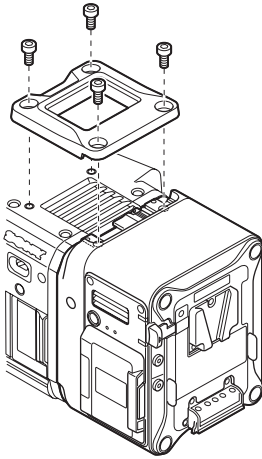

- 2** Insert an AXS memory card into the card slot with the label facing the direction shown in the diagram.

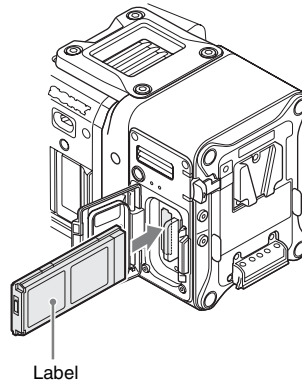

Removing from a Camcorder

- 1** Remove the top plate from the unit and camcorder.
- 2** Press the release button and raise the release lever, then slide the unit upward and pull it out towards you.

Note

Always support the unit with your hand when removing.

Inserting an AXS Memory Card

- 1** Press the memory slot cover open button on the right side to open the cover.

- 3** Close the cover.

Note

Push the cover in until the memory slot cover open button is securely locked.

Removing an AXS Memory Card

Open the memory slot cover on the unit, and extract the AXS memory card by hand.

Note

Data integrity is not guaranteed if the power is turned off or a memory card is removed while it is being accessed. All data recorded on the card may be destroyed. Always check that the memory card ACCESS lamp is lit green or off when you turn off the power or remove a memory card.

Specifications

General

Power requirement

11 V to 17 V DC

Power consumption

Approx. 24 W (4K 59.94P)

Operating temperature

0 °C to 40 °C (32 °F to 104 °F)

Operating humidity

20% to 90%

Storage temperature

-20 °C to +60 °C (-4 °F to +140 °F)

Dimensions

106 × 135 × 93 mm

(4 1/4 × 5 3/8 × 3 3/4 in.)

(width / height / depth)

(Refer to dimensions diagram at the back of this document.)

Mass

Approx. 1.2 kg (2 lb. 10 oz.) (excluding supplied accessories)

Input/output connectors

Extension interface connector

144-pin (1), supplies power

DC IN connector

XLR 4-pin, male (1)

DC OUT connector

Round type 4-pin, female (1)

Battery connector

5-pin (1)

Recording format

Video

F55RAW format

X-OCN format

Audio

Linear PCM (48 kHz/24-bit), 4-channel

Recording/playback time

6K 1.85:1 (using AXS-A512S48) (MPC-3610 only)

X-OCN XT: Approx. 26 minutes (23.98P)

X-OCN ST: Approx. 37 minutes (23.98P)

X-OCN LT: Approx. 64 minutes (23.98P)

6K 2.39:1 (using AXS-A512S48) (MPC-3610 only)

X-OCN XT: Approx. 33 minutes (23.98P)

X-OCN ST: Approx. 48 minutes (23.98P)

X-OCN LT: Approx. 82 minutes (23.98P)

6K 3:2 (using AXS-A512S48) (MPC-3610 only)

X-OCN XT: Approx. 20 minutes (23.98P)

X-OCN ST: Approx. 30 minutes (23.98P)

X-OCN LT: Approx. 52 minutes (23.98P)

6K 17:9 (using AXS-A512S48) (MPC-3610 only)

X-OCN XT: Approx. 26 minutes (23.98P)

X-OCN ST: Approx. 38 minutes (23.98P)

X-OCN LT: Approx. 65 minutes (23.98P)

4K 2.39:1 (using AXS-A512S48) (MPC-3610 only)

X-OCN XT: Approx. 72 minutes (23.98P)

X-OCN ST: Approx. 105 minutes (23.98P)

X-OCN LT: Approx. 177 minutes (23.98P)

4K 4:3 (using AXS-A512S48) (MPC-3610 only)

X-OCN XT: Approx. 41 minutes (23.98P)

X-OCN ST: Approx. 60 minutes (23.98P)

X-OCN LT: Approx. 102 minutes (23.98P)

4K 6:5 (using AXS-A512S48) (MPC-3610 only)

X-OCN XT: Approx. 36 minutes (23.98P)

X-OCN ST: Approx. 53 minutes (23.98P)

X-OCN LT: Approx. 90 minutes (23.98P)

4K 17:9 (using AXS-A512S48)

RAW SQ: Approx. 60 minutes (23.98P)/
Approx. 24 minutes (59.94P)

X-OCN XT: Approx. 57 minutes (23.98P)

X-OCN ST: Approx. 84 minutes (23.98P)/

Approx. 33 minutes (59.94P)

X-OCN LT: Approx. 142 minutes (23.98P)/

Approx. 56 minutes (59.94P)

2K (using AXS-A512S48)

RAW SQ: Approx. 240 minutes (23.98P)/

Approx. 96 minutes (59.94P)

X-OCN ST: Approx. 333 minutes (23.98P)/

Approx. 135 minutes (59.94P)

X-OCN LT: Approx. 506 minutes (23.98P)/

Approx. 207 minutes (59.94P)

Note

The recording/playback time is equivalent to the duration of a single clip recording that fills the media. The recording/playback time may become shorter, depending on the number of recorded clips.

Supplied Accessories

- Top cover (4-598-229-xx) (1)
- Top cover retaining screws (4-562-604-xx) (4)
- Operating Instructions (1)
- Warranty (1)

Design and specifications are subject to change without notice.

Notes

- Always make a test recording, and verify that it was recorded successfully.
SONY WILL NOT BE LIABLE FOR DAMAGES OF ANY KIND INCLUDING, BUT NOT LIMITED TO, COMPENSATION OR REIMBURSEMENT ON ACCOUNT OF FAILURE OF THIS UNIT OR ITS RECORDING MEDIA, EXTERNAL STORAGE SYSTEMS OR ANY OTHER MEDIA OR STORAGE SYSTEMS TO RECORD CONTENT OF ANY TYPE.
- Always verify that the unit is operating properly before use. SONY WILL NOT BE LIABLE FOR DAMAGES OF ANY KIND INCLUDING, BUT NOT LIMITED TO, COMPENSATION OR REIMBURSEMENT ON ACCOUNT OF THE LOSS OF PRESENT OR PROSPECTIVE PROFITS DUE TO FAILURE OF THIS UNIT, EITHER DURING THE WARRANTY PERIOD OR AFTER EXPIRATION OF THE WARRANTY, OR FOR ANY OTHER REASON WHATSOEVER.
- SONY WILL NOT BE LIABLE FOR CLAIMS OF ANY KIND MADE BY USERS OF THIS UNIT OR MADE BY THIRD PARTIES.
- SONY WILL NOT BE LIABLE FOR THE LOSS, REPAIR, OR REPRODUCTION OF ANY DATA RECORDED ON THE INTERNAL STORAGE SYSTEM, RECORDING MEDIA, EXTERNAL STORAGE SYSTEMS OR ANY OTHER MEDIA OR STORAGE SYSTEMS.
- SONY WILL NOT BE LIABLE FOR THE TERMINATION OR DISCONTINUATION OF ANY SERVICES RELATED TO THIS UNIT THAT MAY RESULT DUE TO CIRCUMSTANCES OF ANY KIND.