

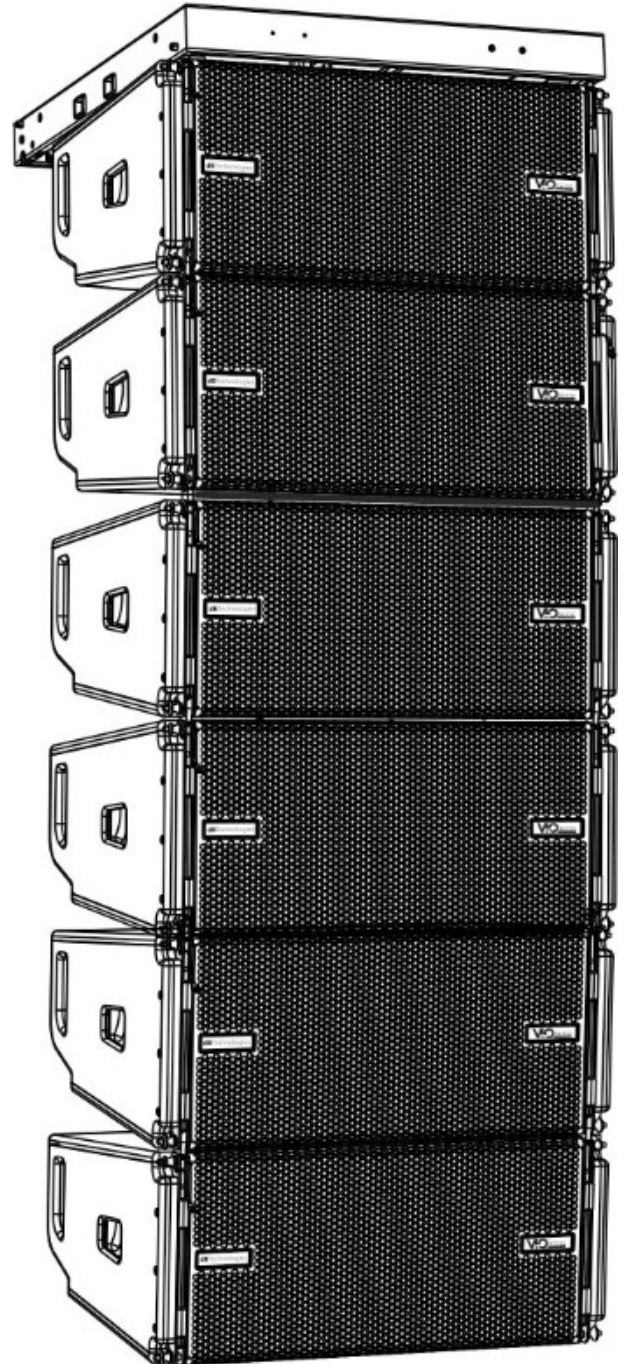

# VIO L1610

*Symmetrical Active 3-Way Line Array  
with Coaxial Driver*

**2x 10" NEODYMIUM WOOFERS  
MD + CD COAX NEODYMIUM DRIVER  
CLASS-D DIGIPRO G4 AMP MODULE  
FULL RANGE SMPS with PFC**



## Quick start user manual Section 1

The warnings in this manual must be observed together with the "USER MANUAL - Section 2".

Le avvertenze nel presente manuale devono essere osservate congiuntamente al "MANUALE D'USO - Sezione 2".

Die Warnungen in diesem Handbuch müssen in Verbindung mit der "BEDIENUNGSANLEITUNG - Abschnitt 2" beobachtet werden".

Les avertissements spécifiés dans ce manuel doivent être respectés ainsi que les "CARACTERISTIQUES TECHNIQUES - Section 2".

Las advertencias del presente manual se deben tener en cuenta conjuntamente con las del "MANUAL DEL USUARIO" - Sección 2".

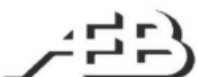

A.E.B. Industriale Srl Via Brodolini, 8 Località Crespellano 40053 VALSAMOGGIA BOLOGNA (ITALIA)  
Tel +39 051 969870 Fax +39 051 969725 [www.dbtechnologies.com](http://www.dbtechnologies.com) [info@dbtechnologies-aeb.com](mailto:info@dbtechnologies-aeb.com)



## Thank you for choosing a dBTechnologies Product!

VIO L1610 is the new dBTechnologies flagship 3-way professional active line array module. It is equipped with: one coaxial neodymium transducer (MF voice coil: 4", HF voice coil: 2,5", HF exit: 1.4") and two 10" neodymium woofers (2.5" voice coil). The full-range acoustical design includes an efficient waveguide and a phase plug with phase correctors, in order to reach the best coherence in line-array configuration. The mechanical design allows an easy, accurate and quick installation in flown or stack use. The powerful DIGIPRO® G4 amplifier section, capable of handling up to 1600 W (RMS power), is controlled by a DSP, which can perform a detailed customization of the output sound of the speaker. In particular, thanks to the new dual rotary encoder interface, it is possible to accurately tune the line-array configuration coverage, using the FIR filter technology. In addition, the integrated RDNET connections are useful for a remote in-depth line-array control and configuration.

Check the site [www.dbtechnologies.com](http://www.dbtechnologies.com) for the complete user manual!

### 1) Unpacking

The box contains:

N°1 VIO L1610

N°1 100-120 V FUSE

This quick start and warranty documentation

### 2) Easy installation

VIO L1610 can be installed in different configurations. For a quick installation, in each side of the loudspeakers the user can find:

Central and rear handles for easy handling (A)

- Two quick-release pin connections for frontal mounting (B), with upper integrated front arms.

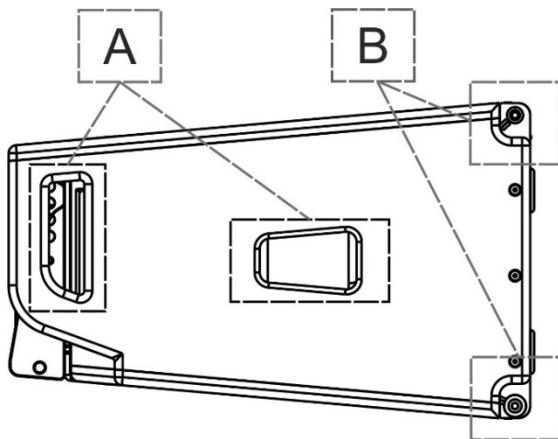

In the rear side the user can find:

- One rear bracket (C) (with movable arm) for line-array mounting, with splay angles reference holes for easy setup and two quick-release pins.

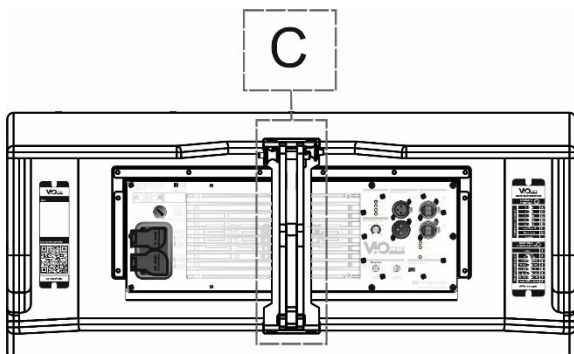

In order to mount the line array, for each module:

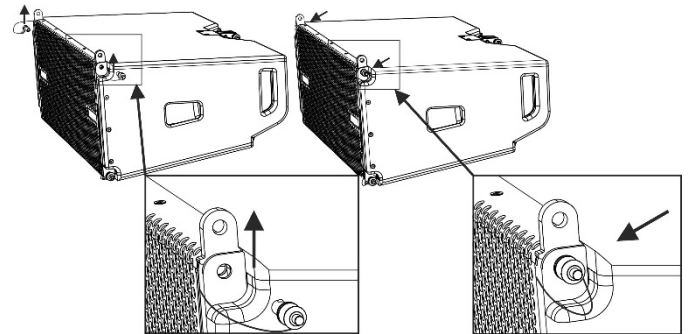

- Remove the upper front pins and lift the front arms in the final position as shown.
- Fasten the arms with the pins in the lower holes.

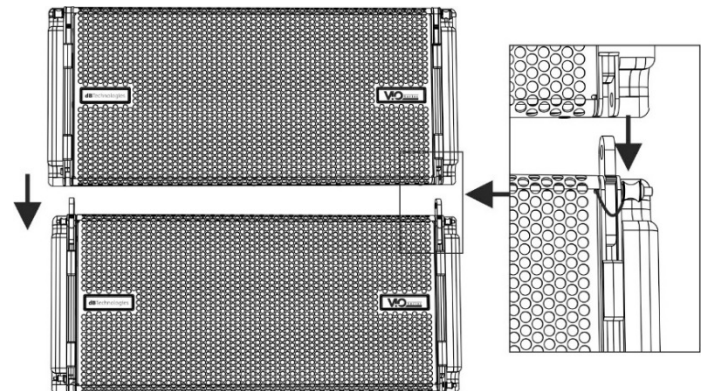

- Put a second VIO L1610 and remove the lower frontal pins.
- Put this second enclosure on the top of the first.
- Insert the front arms in the position shown, aligning the related holes.



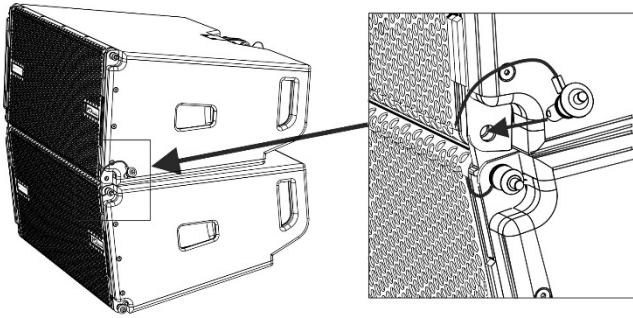

- Fasten the two enclosures using the quick-release pins of the upper VIO L1610.
- Check that all the pins are properly inserted and locked before other mounting steps.

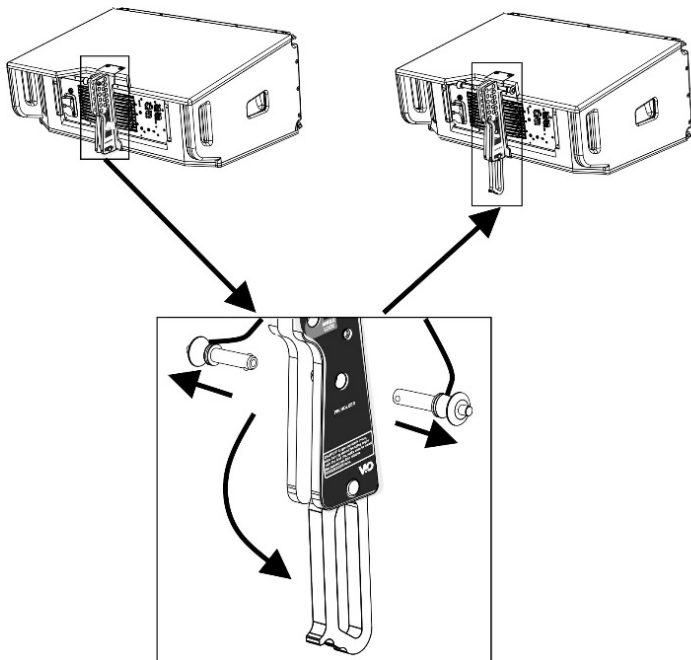

- Remove the rear pins and put the swing rear bracket in the final position as shown.

**!** CHECK PERIODICALLY THE INTEGRITY AND THE FUNCTIONALITY OF THE ENCLOSURE, OF THE PINS AND OF THE BRACKETS, FOR A SAFE INSTALLATION. MAKE SURE THAT THE PINS SECURE PROPERLY THE MODULES AND THAT THEY ARE FULLY LOCKED.

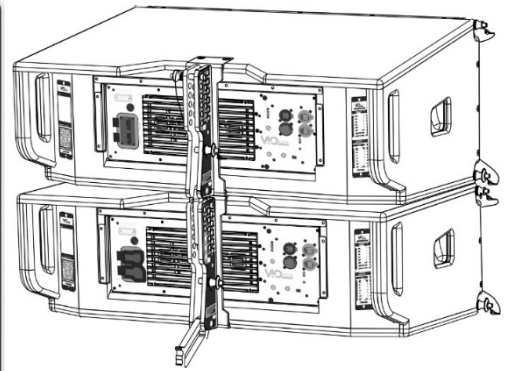
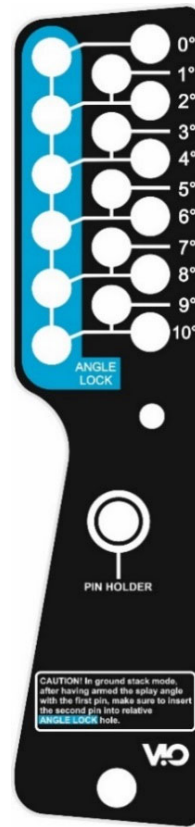

- Insert the movable arm of rear bracket of the upper enclosure into the related housing of the lower one.

- Choose the desired splay angle between the two enclosures.

- If you need a flown installation, only one pin is required to secure the movable arm. Check that the arm is inserted in the bracket. Fasten one of the two rear pins in the desired angle, and let the second one in the position "PIN HOLDER".

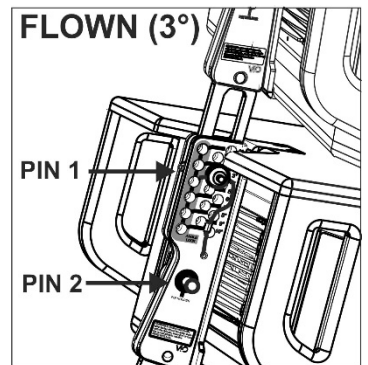

- If you need a stacked installation, it is mandatory to use both the pins to secure the rear bracket. Check that the arm is inserted in the bracket. Fasten one of the two pins in the desired angle. Lift the rear of the upper enclosure to the maximum height allowed by the first pin, and fasten the second pin in the related "ANGLE LOCK" position. Then release the upper enclosure and check that the movable arm leans on the second pin, fastened in the correct position.

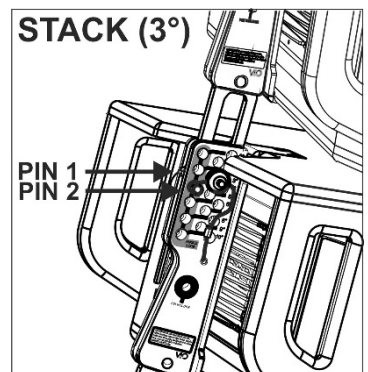

### 3) Accessories

For an easy setup are available among others: a professional fly-bar (DRK-210) for flown and stacked installation, and a trolley (DT-VIOL210) for a quick and safe transport.

#### a) DRK-210 FLY-BAR

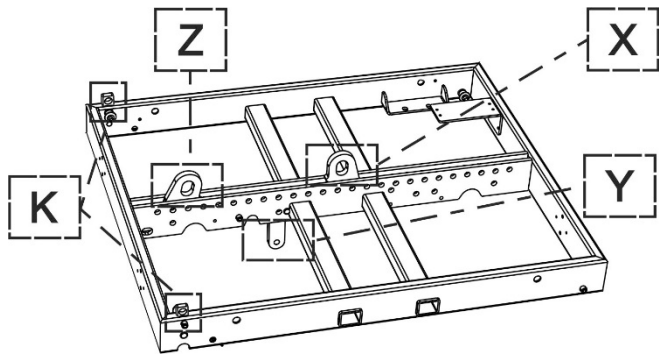
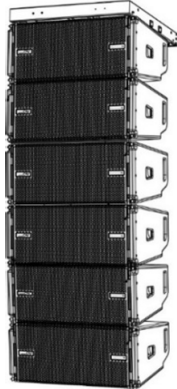

The DRK-210 fly-bar allows different configurations, flown or stacked, for the professional stage use. It has 2 load adaptors (X, Z) for the use of up to two different rigging motors, one rear bracket (Y) specifically designed for the flown installation, and 2 movable bars [K] for stack mounting. The maximum admitted number of cabinets in different configurations depends on various parameters, like VIO L1610 splay angles and DRK-210 tilt.

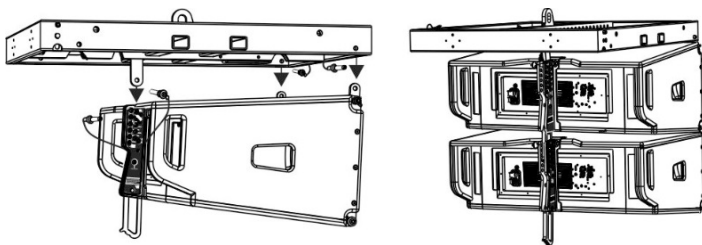

As shown in the picture, in flown installation, the use of the pins and of the rear bracket of DRK-210 make the assembly with the first element of the line-array simple and safe.

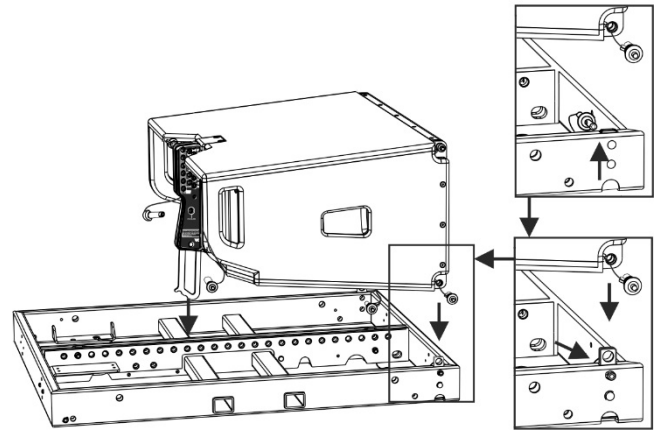

In stacked installation (for example a line-array stacked on a S318 sub), the use of the pins, of the rear bracket of VIO-L1610, and of the 2 movable bars of DRK-210, as shown, make the assembling quick and easy. For further and detailed information please refer to the related DRK-210 user manual.

#### b) DT-VIOL210 TROLLEY

The DT-VIOL210 Trolley can carry up to four VIO L1610s. It has been designed for a quick displacement of the line-array elements. It is provided with wheels and upper coverage to protect the loudspeakers in a safe and ergonomic way.

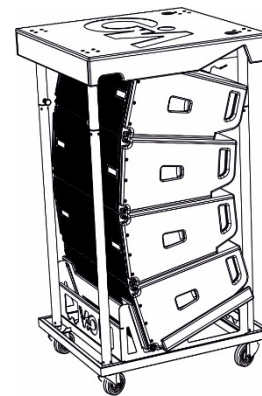

For further and detailed information please refer to the related DT-VIOL210 user manual.



**CHECK PERIODICALLY THE INTEGRITY AND THE FUNCTIONALITY OF THE ACCESSORIES AND OF THE TECHNICAL EQUIPMENTS FOR A SAFE INSTALLATION. USER SHOULD NEVER APPLY A LOAD THAT EXCEEDS THE WORKING LOAD LIMITS OF ANY RIGGING COMPONENTS OR EQUIPMENT HERE PRESENTED. DESIGN, CALCULATION, INSTALLATION, TESTING AND MAINTAINANCE OF SUSPENSION AND STACK SYSTEMS FOR AUDIO EQUIPMENT MUST BE PERFORMED ONLY BY QUALIFIED AND AUTHORIZED PERSONNEL. AEB INDUSTRIALE S.R.L. DENIES ANY AND ALL RESPONSIBILITY FOR IMPROPER INSTALLATIONS, IN THE ABSENCE OF SAFETY REQUIREMENTS.**

## 4) First switch on for line-array setup

The DIGIPRO G4® amplifier of VIO L1610 is controlled by a powerful DSP. All the connections and controls are in the rear amplifier control panel:

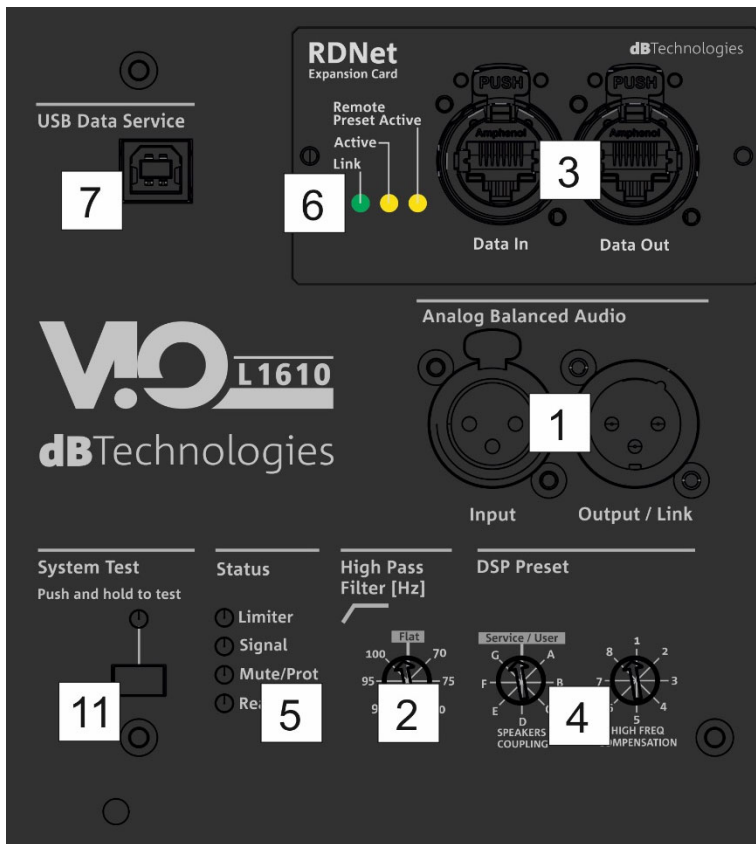

- 1 – Balanced audio input and output link
- 2 – High Pass Filter
- 3 – RDNNet Data In / Data out
- 4 – DSP PRESET rotary switches (Speaker coupling/High frequency compensation)
- 5 – Status LEDs (Limiter, Signal, Mute/Protection, Ready)
- 6 – Control LEDs (Link, Active, Remote preset Active)
- 7 – Mini B-type USB port for firmware updating
- 8 – Auto-range Mains Input
- 9 – Mains link output
- 10 – Mains fuse
- 11 – System test

### WARNING

*The fuse is factory set for 220-240V~ operation.*

*If it is necessary to change the fuse to 100-120V~ range:*

1. Turn off the power and disconnect the speaker from any cable.
2. Wait 5 minutes.
3. Substitute the fuse with the correct one supplied.

a) Once you have properly set up the mechanical line-array configuration (see also the VIO L1610 complete user manual and accessories instructions for further information), connect the audio input (1) of the first module of the array. Then connect the useful link audio output (1) to other VIO L1610 modules, for the connection of all the line-array elements. Set HPF filter (11).

b) Check the rear panel reference label for a proper DSP regulation in line array. Please note that this kind of configuration can be set and modified also by the use of remote controller (RDNet Control 2 or RDNet Control 8) and software (dBTechnologies Network). For this information see the chapter 5.

In this rear label (“PRESETS”) you can find the suggested position of rotary switches (4) for each type of installation (Speakers Coupling positions and High Frequency Compensation). These settings are the main acoustic corrections to create the proper coupling between the elements of your line-array, in order to obtain the best coverage conditions.

In particular, the “SPEAKER COUPLING” rotary acts mainly on low frequencies, and it can be set in 6 positions, depending on the number of elements of line-array.

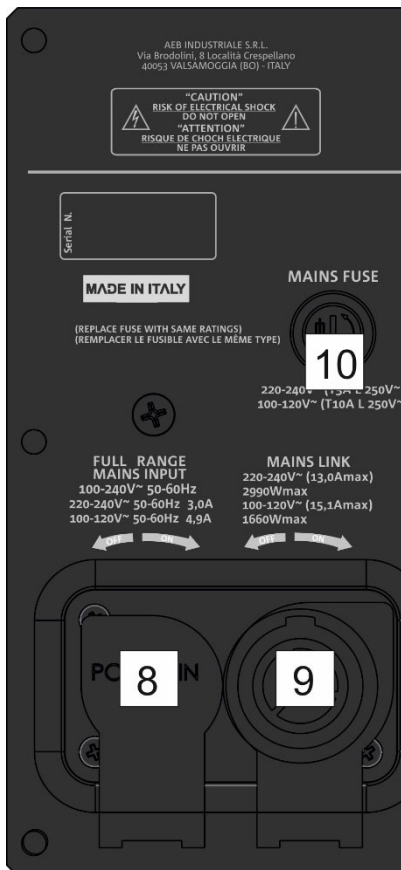

VIO L1610 PRESETS		
SPEAKER COUPLING		
NUMBER OF CABINETS	2 → 6	A
	7 → 8	B
	9 → 10	C
	11 → 12	D
	13 → 14	E
	more than 15	F
	bass boost	G
service		
HIGH FREQ. COMPENSATION		
DISTANCE	SHORT THROW	AIR COMPENSATION
	↑	1
		2
DEFAULT	3	
↓	4	
	5	
	6	
LONG THROW	7	
	8	



A seventh “Bass boost” position assign particular emphasis on the lower frequencies. The “service” one allows USB port communication for firmware updating (or can recall on the speaker user settings previously saved in remote control with dBTechnologies Network). The “HIGH FREQUENCY COMPENSATION” can act on medium-high frequencies. depending on the distance between the line-array and the audience.

c) Connect the power link output (9) of the first module to the mains input (8) of a second VIO L1610 module of the line-array, and so on, in order to link the power supply between all the elements. The maximum linkable rated power and current depends on the first module connection (type of cable, type of connector used).

d) In case of remote control, connect the proper Data Input (3) of the first module of the line-array to the hardware remote controller (RDNet Control 2 or RDNet Control 8) with cables equipped with etherCON connectors. Then connect the Data Output (3) of the first module to the Data Input (3) of the second one, and so on. When the RDNet network is on and it has recognized the connected device, the LED “Link” (6) is on. The other LED (6) “Active” start blinking when there is the presence of data transmission, the “Remote Preset Active” advise that all the local controls set on the amplifier panel (level, DSP presets, etc.) are by-passed and controlled remotely by RDNet. See also RDNet Control 2 and RDNet Control 8 user manuals for further information.

e) Connect the power supply (8) to the first module. The related “Ready” LED (5) turns on, signaling the proper power connection. The “Signal” LED (5) start blinking at the presence of audio signal (greater than -20dBu). Avoid audio distortion conditions, potentially signaled by the “Limiter” LED (5).

## 5) Software (dBTechnologies Aurora)

VIO L1610 can be fully remote controlled via RDNet. The connection details have been illustrated in the chapter 4 (“d” point). In remote control mode, the use of free professional software, developed by dBTechnologies, allows a complete system management: dBTechnologies AURORA NET.

### a) dBTechnologies Aurora NET

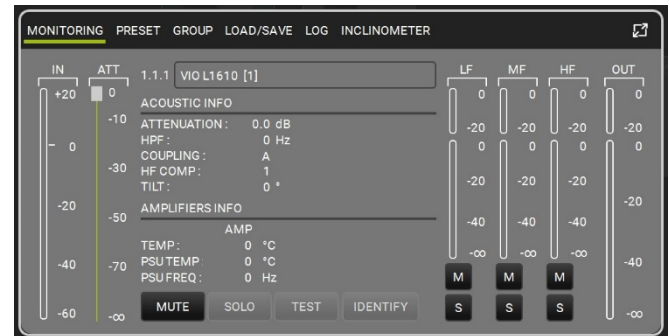

The software which must be used in case of remote control is dBTechnologies AURORA NET. This software can control different speakers in different configurations.

It allows a complete remote control and a full real-time monitoring in various scenarios. For example, the user can control a setup with 2 line-arrays of VIO L1610 and 3 VIO S318 subwoofers, and change different parameters while the entire system is sounding.

It can also offer a deeper loudspeaker control than the simple rear amplifier panel rotaries.

It can be downloaded for free from the official site:

[www.dbtechnologies.com/EN/Downloads.aspx](http://www.dbtechnologies.com/EN/Downloads.aspx)

Check always for software updates!

## Technical Data

**Speaker Type:** 3-way professional active line-array element

### Acoustical data

**Max SPL (@1m):** 141 dB

**Frequency response [-10 dB]:** 56 Hz – 20 kHz

**Frequency response [-6 dB]:** 60 Hz – 17 kHz

**HF/MF:** coaxial, neodymium, 1.4" exit

**HF/MF voice coil:** 2.5" / 4"

**LF:** 2x 10" (voice coil: 2.5"), neodymium

**Xover frequencies:** 500 Hz – 3300 Hz

**Horizontal dispersion ([-6dB] 500 – 18100 Hz):** 100°

**Vertical dispersion:** varies on number of modules and configurations

### Amplifier

**Amp Technology:** Digipro® G4 - Autorange

**Amp Class:** Class-D

**RMS Power:** 1600 W

**Peak Power:** 3200 W

**Cooling:** Passive (convection) + fan

**Operating range:** 220-240V~ (50-60Hz)/100-120V~ (50-60 Hz)

## Processor

**Controller:** DSP, 32/96 bit

**AD/DA conversion:** 24 bit /96 kHz

**Limiter:** Dual Active Peak, RMS, Thermal

**Controls:** HPF filter, DSP presets, system test

**Advanced DSP function:** Linear Phase FIR filters

**Rotary presets:** 2 Rotary BCD 8 positions for line-array configuration (Speaker Coupling, High Frequency Compensation)

## Input / Output

**Mains connections:** PowerCON® TRUE1 In / Link

**Signal Input:** (Balanced) 1x XLR IN

**Signal Out:** (Balanced) 1 x XLR link OUT

**RDNET connectors:** Data In / Data Out

**USB connector:** USB B-type (for SERVICE DATA)

## Mechanics

**Housing:** Wooden box – Black polyurea finished

**Grille:** CNC machined full metal grille

**Rigging points:** 3 (Easy Rigging)

**Handles:** 2 for each side

**Width:** 720 mm (28.35 in)

**Height:** 320 mm (12.60 in)

**Depth:** 520 mm (20.47 in)

**Weight:** 31,3 kg (69 lbs)



### POWER SUPPLY SPECIFICATIONS (POWER ABSORPTION)

**Draw at 1/8 of full power in average use conditions (\*):** 1.4 A (220-240V~) - 2.1 A (100-120V~)

**Draw at 1/3 of full power in maximum use conditions (\*\*):** 3 A (220-240V~) - 4.9 A (100-120V~)

**Power absorption with speaker turned on without signal (idle):** 33 W

*\* INSTALLER NOTES: The values refer to 1/8 of full power, in average operating conditions (music program with infrequent or no clipping). It is recommended to consider them the minimum sizing values for any type of configuration.*

*\*\* INSTALLER NOTES: The values refer to 1/3 of full power, in heavy operating conditions (music program with frequent clipping or activation of the limiter). We recommend sizing according to these values in case of professional installations and tours.*

Download the complete user manual on:

[www.dbtechnologies.com/EN/Downloads.aspx](http://www.dbtechnologies.com/EN/Downloads.aspx)

### EMI CLASSIFICATION

According to the standards EN 55032 and 55035 this is a Class A equipment, designed and suitable to operate for professional use. **Warning:** This equipment is compliant with Class A of CISPR 32. In a residential environment this equipment may cause radio interference.

### FCC CLASS A STATEMENT

Any changes or modifications not expressly approved by the party responsible for compliance could void the user's authority to operate the equipment.

This equipment has been tested and found to comply with the limits for a Class A digital device, pursuant to part 15 of the FCC Rules. These limits are designed to provide reasonable protection against harmful interference when the equipment is operated in a commercial environment. This equipment generates, uses, and can radiate radio frequency energy and, if not installed and used in accordance with the instruction manual, may cause harmful interference to radio communications. Operation of this equipment in a residential area is likely to cause harmful interference in which case the user will be required to correct the interference at his own expense.

**WARNING:** Make sure that the loudspeaker is securely installed in a stable position to avoid any injuries or damages to persons or properties. For safety reasons do not place one loudspeaker on top of another without proper fastening systems. Before hanging the loudspeaker check all the components for damages, deformations, missing or damaged parts that may compromise safety during installation. If you use the loudspeakers outdoor avoid spots exposed to bad weather conditions.

Contact dB Technologies for accessories to be used with speakers. dBTechnologies will not accept any responsibility for damages caused by inappropriate accessories or additional devices.

*Features, specification and appearance of products are subject to change without notice.*

*dBTechnologies reserves the right to make changes or improvements in design or manufacturing without assuming any obligation to change or improve products previously manufactured*